

GNU Octave

A high-level interactive language for numerical computations
Edition 3 for Octave version 2.1.x
February 1997

John W. Eaton

Copyright © 1996, 1997 John W. Eaton.

This is the third edition of the Octave documentation, and is consistent with version 2.1.x of Octave.

Permission is granted to make and distribute verbatim copies of this manual provided the copyright notice and this permission notice are preserved on all copies.

Permission is granted to copy and distribute modified versions of this manual under the conditions for verbatim copying, provided that the entire resulting derived work is distributed under the terms of a permission notice identical to this one.

Permission is granted to copy and distribute translations of this manual into another language, under the same conditions as for modified versions.

Portions of this document have been adapted from the `gawk`, `readline`, `gcc`, and C library manuals, published by the Free Software Foundation, 59 Temple Place—Suite 330, Boston, MA 02111-1307, USA.

Table of Contents

Preface	1
Acknowledgements	1
How You Can Contribute to Octave	4
Distribution	4
1 A Brief Introduction to Octave	5
1.1 Running Octave	5
1.2 Simple Examples	5
Creating a Matrix	5
Matrix Arithmetic	6
Solving Linear Equations	6
Integrating Differential Equations	6
Producing Graphical Output	7
Editing What You Have Typed	7
Help and Documentation	8
1.3 Conventions	8
1.3.1 Fonts	8
1.3.2 Evaluation Notation	8
1.3.3 Printing Notation	9
1.3.4 Error Messages	9
1.3.5 Format of Descriptions	9
1.3.5.1 A Sample Function Description	9
1.3.5.2 A Sample Command Description	10
1.3.5.3 A Sample Variable Description	11
2 Getting Started	13
2.1 Invoking Octave	13
2.1.1 Command Line Options	13
2.1.2 Startup Files	15
2.2 Quitting Octave	16
2.3 Commands for Getting Help	16
2.4 Command Line Editing	18
2.4.1 Cursor Motion	18
2.4.2 Killing and Yanking	19
2.4.3 Commands For Changing Text	19
2.4.4 Letting Readline Type For You	20
2.4.5 Commands For Manipulating The History	20
2.4.6 Customizing <code>readline</code>	22
2.4.7 Customizing the Prompt	22
2.4.8 Diary and Echo Commands	23
2.5 How Octave Reports Errors	24
2.6 Executable Octave Programs	25
2.7 Comments in Octave Programs	26

3	Data Types	29
3.1	Built-in Data Types	29
3.1.1	Numeric Objects	29
3.1.2	Missing Data	29
3.1.3	String Objects	30
3.1.4	Data Structure Objects	30
3.2	User-defined Data Types	30
3.3	Object Sizes	30
4	Numeric Data Types	33
4.1	Matrices	33
4.1.1	Empty Matrices	36
4.2	Ranges	37
4.3	Logical Values	37
4.4	Predicates for Numeric Objects	38
5	Strings	39
5.1	Creating Strings	40
5.2	Searching and Replacing	41
5.3	String Conversions	43
5.4	Character Class Functions	46
6	Data Structures	47
7	Containers	51
7.1	Lists	51
7.2	Cell Arrays	51
8	I/O Streams	53
9	Variables	55
9.1	Global Variables	55
9.2	Persistent Variables	56
9.3	Status of Variables	57
9.4	Summary of Built-in Variables	59
9.5	Defaults from the Environment	64

10	Expressions	65
10.1	Index Expressions	65
10.2	Calling Functions	66
10.2.1	Call by Value	67
10.2.2	Recursion	68
10.3	Arithmetic Operators	68
10.4	Comparison Operators	70
10.5	Boolean Expressions	70
10.5.1	Element-by-element Boolean Operators	71
10.5.2	Short-circuit Boolean Operators	71
10.6	Assignment Expressions	72
10.7	Increment Operators	74
10.8	Operator Precedence	75
11	Evaluation	77
12	Statements	79
12.1	The <code>if</code> Statement	79
12.2	The <code>switch</code> Statement	81
12.3	The <code>while</code> Statement	82
12.4	The <code>do-until</code> Statement	83
12.5	The <code>for</code> Statement	84
12.5.1	Looping Over Structure Elements	84
12.6	The <code>break</code> Statement	85
12.7	The <code>continue</code> Statement	86
12.8	The <code>unwind_protect</code> Statement	87
12.9	The <code>try</code> Statement	88
12.10	Continuation Lines	88
13	Functions and Script Files	91
13.1	Defining Functions	91
13.2	Multiple Return Values	93
13.3	Variable-length Argument Lists	95
13.4	Variable-length Return Lists	95
13.5	Returning From a Function	95
13.6	Function Files	96
13.7	Script Files	98
13.8	Dynamically Linked Functions	100
13.9	Function Handles and Inline	103
13.9.1	Function Handles	103
13.9.2	Inline Functions	103
13.10	Organization of Functions Distributed with Octave	104
14	Error Handling	105
15	Debugging	107

16	Input and Output	109
16.1	Basic Input and Output	110
16.1.1	Terminal Output	110
16.1.2	Terminal Input	113
16.1.3	Simple File I/O	114
16.2	C-Style I/O Functions	117
16.2.1	Opening and Closing Files	118
16.2.2	Simple Output	119
16.2.3	Line-Oriented Input	119
16.2.4	Formatted Output	119
16.2.5	Output Conversion for Matrices	121
16.2.6	Output Conversion Syntax	121
16.2.7	Table of Output Conversions	122
16.2.8	Integer Conversions	123
16.2.9	Floating-Point Conversions	123
16.2.10	Other Output Conversions	124
16.2.11	Formatted Input	124
16.2.12	Input Conversion Syntax	126
16.2.13	Table of Input Conversions	126
16.2.14	Numeric Input Conversions	127
16.2.15	String Input Conversions	127
16.2.16	Binary I/O	128
16.2.17	Temporary Files	130
16.2.18	End of File and Errors	131
16.2.19	File Positioning	132
17	Plotting	133
17.1	Two-Dimensional Plotting	133
17.2	Specialized Two-Dimensional Plots	138
17.3	Three-Dimensional Plotting	141
17.4	Plot Annotations	142
17.5	Multiple Plots on One Page	143
17.6	Multiple Plot Windows	144
17.7	Interaction with <code>gnuplot</code>	145
18	Matrix Manipulation	147
18.1	Finding Elements and Checking Conditions	147
18.2	Rearranging Matrices	149
18.3	Special Utility Matrices	155
18.4	Famous Matrices	158

19	Arithmetic	161
	19.1 Utility Functions	161
	19.2 Complex Arithmetic	164
	19.3 Trigonometry	165
	19.4 Sums and Products	167
	19.5 Special Functions	167
	19.6 Coordinate Transformations	170
	19.7 Mathematical Constants	171
20	Linear Algebra	173
	20.1 Basic Matrix Functions	173
	20.2 Matrix Factorizations	176
	20.3 Functions of a Matrix	180
21	Nonlinear Equations	183
22	Quadrature	185
	22.1 Functions of One Variable	185
	22.2 Orthogonal Collocation	186
23	Differential Equations	187
	23.1 Ordinary Differential Equations	187
	23.2 Differential-Algebraic Equations	191
24	Optimization	199
	24.1 Linear Programming	199
	24.2 Quadratic Programming	199
	24.3 Nonlinear Programming	199
	24.4 Linear Least Squares	199
25	Statistics	201
	25.1 Basic Statistical Functions	201
	25.2 Tests	206
	25.3 Models	213
	25.4 Distributions	214
26	Financial Functions	225
27	Sets	227
28	Polynomial Manipulations	229

29	Control Theory	233
29.1	System Data Structure	233
29.1.1	Variables common to all OCST system formats..	234
29.1.2	tf format variables	234
29.1.3	zp format variables	235
29.1.4	ss format variables	235
29.2	System Construction and Interface Functions	235
29.2.1	Finite impulse response system interface functions	235
29.2.2	State space system interface functions	236
29.2.3	Transfer function system interface functions . . .	239
29.2.4	Zero-pole system interface functions	240
29.2.5	Data structure access functions	241
29.2.6	Data structure internal functions	245
29.3	System display functions	246
29.4	Block Diagram Manipulations	246
29.5	Numerical Functions	255
29.6	System Analysis-Properties	259
29.7	System Analysis-Time Domain	264
29.8	System Analysis-Frequency Domain	267
29.9	Controller Design	270
29.10	Miscellaneous Functions (Not yet properly filed/documentated)	278
30	Signal Processing	283
31	Image Processing	291
32	Audio Processing	295
33	Quaternions	297
34	System Utilities	299
34.1	Timing Utilities	299
34.2	Filesystem Utilities	304
34.3	Controlling Subprocesses	307
34.4	Process, Group, and User IDs	311
34.5	Environment Variables	312
34.6	Current Working Directory	312
34.7	Password Database Functions	313
34.8	Group Database Functions	314
34.9	System Information	314

Appendix A	Tips and Standards	317
A.1	Writing Clean Octave Programs	317
A.2	Tips for Making Code Run Faster.....	317
A.3	Tips for Documentation Strings.....	318
A.4	Tips on Writing Comments	319
A.5	Conventional Headers for Octave Functions	319
Appendix B	Known Causes of Trouble	323
B.1	Actual Bugs We Haven't Fixed Yet	323
B.2	Reporting Bugs.....	324
B.3	Have You Found a Bug?.....	324
B.4	Where to Report Bugs	325
B.5	How to Report Bugs	325
B.6	Sending Patches for Octave.....	327
B.7	How To Get Help with Octave.....	327
Appendix C	Installing Octave	329
C.1	Installation Problems	331
Appendix D	Emacs Octave Support	335
D.1	Installing EOS	335
D.2	Using Octave Mode.....	335
D.3	Running Octave From Within Emacs.....	339
D.4	Using the Emacs Info Reader for Octave.....	340
Appendix E	Grammar	343
E.1	Keywords	343
Appendix F	GNU GENERAL PUBLIC LICENSE	345
F.1	Preamble.....	345
F.2	TERMS AND CONDITIONS FOR COPYING, DISTRIBUTION AND MODIFICATION	346
F.3	Appendix: How to Apply These Terms to Your New Programs	350
Concept Index		353
Variable Index		357
Function Index		359
Operator Index		369

Preface

Octave was originally intended to be companion software for an undergraduate-level textbook on chemical reactor design being written by James B. Rawlings of the University of Wisconsin-Madison and John G. Ekerdt of the University of Texas.

Clearly, Octave is now much more than just another ‘courseware’ package with limited utility beyond the classroom. Although our initial goals were somewhat vague, we knew that we wanted to create something that would enable students to solve realistic problems, and that they could use for many things other than chemical reactor design problems.

There are those who would say that we should be teaching the students Fortran instead, because that is the computer language of engineering, but every time we have tried that, the students have spent far too much time trying to figure out why their Fortran code crashes and not enough time learning about chemical engineering. With Octave, most students pick up the basics quickly, and are using it confidently in just a few hours.

Although it was originally intended to be used to teach reactor design, it has been used in several other undergraduate and graduate courses in the Chemical Engineering Department at the University of Texas, and the math department at the University of Texas has been using it for teaching differential equations and linear algebra as well. If you find it useful, please let us know. We are always interested to find out how Octave is being used in other places.

Virtually everyone thinks that the name Octave has something to do with music, but it is actually the name of a former professor of mine who wrote a famous textbook on chemical reaction engineering, and who was also well known for his ability to do quick ‘back of the envelope’ calculations. We hope that this software will make it possible for many people to do more ambitious computations just as easily.

Everyone is encouraged to share this software with others under the terms of the GNU General Public License (see Appendix F [Copying], page 345) as described at the beginning of this manual. You are also encouraged to help make Octave more useful by writing and contributing additional functions for it, and by reporting any problems you may have.

Acknowledgements

Many people have already contributed to Octave’s development. In addition to John W. Eaton, the following people have helped write parts of Octave or helped out in various other ways.

- Thomas Baier baier@ci.tuwien.ac.at wrote the original versions of `popen`, `pclose`, `execute`, `sync_system`, and `async_system`.
- David Bateman dbateman@free.fr improved the `sort` and `min/max` functions, made many functions N-d aware, converted several built-in functions to use Lapack instead of Linpack, split the functionality of ‘`load-save.cc`’ out into the `octave_value` classes, and has contributed in many other ways.
- Karl Berry karl@cs.umb.edu wrote the `kpathsea` library that allows Octave to recursively search directory paths for function and script files.
- Georg Beyerle gbeyerle@awi-potsdam.de contributed code to save values in MATLAB’s ‘`.mat`’-file format, and has provided many useful bug reports and suggestions.

- John Campbell `jcc@bevo.che.wisc.edu` wrote most of the file and C-style input and output functions.
- Dirk Eddelbuettel `edd@debian.org` made Octave easy to install for users of Debian GNU/Linux.
- Brian Fox `bfox@gnu.org` wrote the `readline` library used for command history editing, and the portion of this manual that documents it.
- Klaus Gebhardt `gebhardt@crunch.ikp.physik.th-darmstadt.de` ported Octave to OS/2.
- Kai Habel `kai.habel@gmx.de` implemented functions for performing coordinate transformations.
- A. Scottedward Hodel `A.S.Hodel@eng.auburn.edu` contributed a number of functions including `expm`, `qzval`, `qzhess`, `syl`, `lyap`, and `balance`.
- Kurt Hornik `Kurt.Hornik@ci.tuwien.ac.at` provided the `corrcoef`, `cov`, `fftconv`, `fftfilt`, `gcd`, `lcd`, `kurtosis`, `null`, `orth`, `poly`, `polyfit`, `roots`, and `skewness` functions, supplied documentation for these and numerous other functions, rewrote the Emacs mode for editing Octave code and provided its documentation, and has helped tremendously with testing. He has also been a constant source of new ideas for improving Octave.
- Cai Jianming `caijianming@yahoo.co.uk` contributed the initial cell array implementation.
- Phil Johnson `johnsonp@nicco.sscnet.ucla.edu` has helped to make Linux releases available.
- Steven G. Johnson `stevenj@alum.mit.edu` added support for ATLAS, saving data in HDF5 files, and ported Octave's configure script to Autoconf 2.50.
- Mumit Khan `khan@nanotech.wisc.edu` helped make it possible for Octave to be compiled by ISO standard C++ compilers other than GCC.
- Paul Kienzle `pkienzle@users.sf.net` has provided many enhancements to improve Octave's compatibility with MATLAB, and also maintains the collection of contributed code at <http://octave.sf.net>.
- Bill Lash `lash@tellabs.com` provided the `unwrap` function.
- Dirk Laurie `dirk@calvyn.puk.ac.za` rewrote `invhilb` to be faster and more accurate.
- Friedrich Leisch `leisch@ci.tuwien.ac.at` provided the `mahalanobis` function.
- Ken Neighbors `wkn@leland.stanford.edu` has provided many useful bug reports and comments on MATLAB compatibility.
- Rick Niles `niles@axp745.gsfc.nasa.gov` rewrote Octave's plotting functions to add line styles and the ability to specify an unlimited number of lines in a single call. He also continues to track down odd incompatibilities and bugs.
- Mark Odegard `meo@getech.com` provided the initial implementation of `fread`, `fwrite`, `feof`, and `ferror`.
- Gabriele Pannocchia `pannocchia@ing.unipi.it` provided the `dkalman.m` function, added support for singular system matrices to `dlqe` and `dlqr`, and has made various other improvements to the control system functions.

- Tony Richardson `richardson@evansville.edu` wrote Octave's image processing functions as well as most of the original polynomial functions.
- Petter Risholm `Petter.Risholm@idi.ntnu.no` helped to implement much of Octave's N-d array functionality.
- Ben Sapp `bsapp@lanl.gov` implemented the debugger functions and added Texinfo markup commands to the internal doc strings.
- R. Bruce Tenison `btenison@rstc.cc.al.us` wrote the `hess` and `schur` functions.
- Teresa Twaroch `twaroch@ci.tuwien.ac.at` provided the functions `gls` and `ols`.
- James R. Van Zandt `jrv@vanzandt.mv.com` added support for reading and writing MATLAB version 5 binary data files.
- Andreas Weingessel `Andreas.Weingessel@ci.tuwien.ac.at` wrote the audio functions `lin2mu`, `loadaudio`, `mu2lin`, `playaudio`, `record`, `saveaudio`, and `setaudio`.
- Fook Fah Yap `ffiy@eng.cam.ac.uk` provided the `fft` and `ifft` functions and valuable bug reports for early versions.

Special thanks to the following people and organizations for supporting the development of Octave:

- The National Science Foundation, through grant numbers CTS-0105360, CTS-9708497, CTS-9311420, and CTS-8957123.
- The industrial members of the Texas-Wisconsin Modeling and Control Consortium (TWMCC (<http://www.che.utexas.edu/twmcc>)).
- The Paul A. Elfers Endowed Chair in Chemical Engineering at the University of Wisconsin-Madison.
- Digital Equipment Corporation, for an equipment grant as part of their External Research Program.
- Sun Microsystems, Inc., for an Academic Equipment grant.
- International Business Machines, Inc., for providing equipment as part of a grant to the University of Texas College of Engineering.
- Texaco Chemical Company, for providing funding to continue the development of this software.
- The University of Texas College of Engineering, for providing a Challenge for Excellence Research Supplement, and for providing an Academic Development Funds grant.
- The State of Texas, for providing funding through the Texas Advanced Technology Program under Grant No. 003658-078.
- Noel Bell, Senior Engineer, Texaco Chemical Company, Austin Texas.
- James B. Rawlings, Professor, University of Wisconsin-Madison, Department of Chemical Engineering.
- Richard Stallman, for writing GNU.

This project would not have been possible without the GNU software used in and used to produce Octave.

How You Can Contribute to Octave

There are a number of ways that you can contribute to help make Octave a better system. Perhaps the most important way to contribute is to write high-quality code for solving new problems, and to make your code freely available for others to use.

If you find Octave useful, consider providing additional funding to continue its development. Even a modest amount of additional funding could make a significant difference in the amount of time that is available for development and support.

If you cannot provide funding or contribute code, you can still help make Octave better and more reliable by reporting any bugs you find and by offering suggestions for ways to improve Octave. See Appendix B [Trouble], page 323, for tips on how to write useful bug reports.

Distribution

Octave is *free* software. This means that everyone is free to use it and free to redistribute it on certain conditions. Octave is not in the public domain. It is copyrighted and there are restrictions on its distribution, but the restrictions are designed to ensure that others will have the same freedom to use and redistribute Octave that you have. The precise conditions can be found in the GNU General Public License that comes with Octave and that also appears in Appendix F [Copying], page 345.

Octave is available on CD-ROM with various collections of other free software, and from the Free Software Foundation. Ordering a copy of Octave from the Free Software Foundation helps to fund the development of more free software. For more information, write to

Free Software Foundation
59 Temple Place—Suite 330
Boston, MA 02111-1307
USA

Octave is also available on the Internet from <ftp://ftp.che.wisc.edu/pub/octave>, and additional information is available from <http://www.che.wisc.edu/octave>.

1 A Brief Introduction to Octave

This manual documents how to run, install and port GNU Octave, and how to report bugs.

GNU Octave is a high-level language, primarily intended for numerical computations. It provides a convenient command line interface for solving linear and nonlinear problems numerically, and for performing other numerical experiments. It may also be used as a batch-oriented language.

GNU Octave is also freely redistributable software. You may redistribute it and/or modify it under the terms of the GNU General Public License as published by the Free Software Foundation. The GPL is included in this manual in Appendix F [Copying], page 345.

This document corresponds to Octave version 2.1.x.

1.1 Running Octave

On most systems, the way to invoke Octave is with the shell command ‘`octave`’. Octave displays an initial message and then a prompt indicating it is ready to accept input. You can begin typing Octave commands immediately afterward.

If you get into trouble, you can usually interrupt Octave by typing *Control-C* (usually written *C-c* for short). *C-c* gets its name from the fact that you type it by holding down CTRL and then pressing C. Doing this will normally return you to Octave’s prompt.

To exit Octave, type *quit*, or *exit* at the Octave prompt.

On systems that support job control, you can suspend Octave by sending it a SIGTSTP signal, usually by typing *C-z*.

1.2 Simple Examples

The following chapters describe all of Octave’s features in detail, but before doing that, it might be helpful to give a sampling of some of its capabilities.

If you are new to Octave, I recommend that you try these examples to begin learning Octave by using it. Lines marked with ‘`octave:13>`’ are lines you type, ending each with a carriage return. Octave will respond with an answer, or by displaying a graph.

Creating a Matrix

To create a new matrix and store it in a variable so that it you can refer to it later, type the command

```
octave:1> a = [ 1, 1, 2; 3, 5, 8; 13, 21, 34 ]
```

Octave will respond by printing the matrix in neatly aligned columns. Ending a command with a semicolon tells Octave to not print the result of a command. For example

```
octave:2> b = rand (3, 2);
```

will create a 3 row, 2 column matrix with each element set to a random value between zero and one.

To display the value of any variable, simply type the name of the variable. For example, to display the value stored in the matrix `b`, type the command

```
octave:3> b
```

Matrix Arithmetic

Octave has a convenient operator notation for performing matrix arithmetic. For example, to multiply the matrix `a` by a scalar value, type the command

```
octave:4> 2 * a
```

To multiply the two matrices `a` and `b`, type the command

```
octave:5> a * b
```

To form the matrix product $\mathbf{a}^T \mathbf{a}$, type the command

```
octave:6> a' * a
```

Solving Linear Equations

To solve the set of linear equations $\mathbf{ax} = \mathbf{b}$, use the left division operator, `\`:

```
octave:7> a \ b
```

This is conceptually equivalent to $\mathbf{a}^{-1}\mathbf{b}$, but avoids computing the inverse of a matrix directly.

If the coefficient matrix is singular, Octave will print a warning message and compute a minimum norm solution.

Integrating Differential Equations

Octave has built-in functions for solving nonlinear differential equations of the form

$$\frac{dx}{dt} = f(x, t), \quad x(t = t_0) = x_0$$

For Octave to integrate equations of this form, you must first provide a definition of the function $f(x, t)$. This is straightforward, and may be accomplished by entering the function body directly on the command line. For example, the following commands define the right hand side function for an interesting pair of nonlinear differential equations. Note that while you are entering a function, Octave responds with a different prompt, to indicate that it is waiting for you to complete your input.

```
octave:8> function xdot = f (x, t)
>
> r = 0.25;
> k = 1.4;
> a = 1.5;
> b = 0.16;
> c = 0.9;
> d = 0.8;
>
> xdot(1) = r*x(1)*(1 - x(1)/k) - a*x(1)*x(2)/(1 + b*x(1));
> xdot(2) = c*a*x(1)*x(2)/(1 + b*x(1)) - d*x(2);
>
> endfunction
```

Given the initial condition

```
x0 = [1; 2];
```

and the set of output times as a column vector (note that the first output time corresponds to the initial condition given above)

```
t = linspace (0, 50, 200)';
```

it is easy to integrate the set of differential equations:

```
x = lsode ("f", x0, t);
```

The function `lsode` uses the Livermore Solver for Ordinary Differential Equations, described in A. C. Hindmarsh, *ODEPACK, a Systematized Collection of ODE Solvers*, in: Scientific Computing, R. S. Stepleman et al. (Eds.), North-Holland, Amsterdam, 1983, pages 55–64.

Producing Graphical Output

To display the solution of the previous example graphically, use the command

```
plot (t, x)
```

If you are using the X Window System, Octave will automatically create a separate window to display the plot. If you are using a terminal that supports some other graphics commands, you will need to tell Octave what kind of terminal you have. Type the command

```
gset term
```

to see a list of the supported terminal types. Octave uses `gnuplot` to display graphics, and can display graphics on any terminal that is supported by `gnuplot`.

To capture the output of the plot command in a file rather than sending the output directly to your terminal, you can use a set of commands like this

```
gset term postscript
gset output "foo.ps"
replot
```

This will work for other types of output devices as well. Octave's `gset` command is really just piped to the `gnuplot` subprocess, so that once you have a plot on the screen that you like, you should be able to do something like this to create an output file suitable for your graphics printer.

Or, you can eliminate the intermediate file by using commands like this

```
gset term postscript
gset output "|lpr -Pname_of_your_graphics_printer"
replot
```

Editing What You Have Typed

At the Octave prompt, you can recall, edit, and reissue previous commands using Emacs- or vi-style editing commands. The default keybindings use Emacs-style commands. For example, to recall the previous command, type *Control-p* (usually written *C-p* for short). *C-p* gets its name from the fact that you type it by holding down `CTRL` and then pressing `p`. Doing this will normally bring back the previous line of input. *C-n* will bring up the next line of input, *C-b* will move the cursor backward on the line, *C-f* will move the cursor forward on the line, etc.

A complete description of the command line editing capability is given in this manual in Section 2.4 [Command Line Editing], page 18.

Help and Documentation

Octave has an extensive help facility. The same documentation that is available in printed form is also available from the Octave prompt, because both forms of the documentation are created from the same input file.

In order to get good help you first need to know the name of the command that you want to use. This name of the function may not always be obvious, but a good place to start is to just type `help`. This will show you all the operators, reserved words, functions, built-in variables, and function files. You can then get more help on anything that is listed by simply including the name as an argument to help. For example,

```
help plot
```

will display the help text for the `plot` function.

Octave sends output that is too long to fit on one screen through a pager like `less` or `more`. Type a `RET` to advance one line, a `SPC` to advance one page, and `q` to exit the pager.

The part of Octave's help facility that allows you to read the complete text of the printed manual from within Octave normally uses a separate program called Info. When you invoke Info you will be put into a menu driven program that contains the entire Octave manual. Help for using Info is provided in this manual in Section 2.3 [Getting Help], page 16.

1.3 Conventions

This section explains the notational conventions that are used in this manual. You may want to skip this section and refer back to it later.

1.3.1 Fonts

Examples of Octave code appear in this font or form: `svd (a)`. Names that represent arguments or metasyntactic variables appear in this font or form: *first-number*. Commands that you type at the shell prompt sometimes appear in this font or form: `'octave --no-init-file'`. Commands that you type at the Octave prompt sometimes appear in this font or form: `foo --bar --baz`. Specific keys on your keyboard appear in this font or form: `ANY`.

1.3.2 Evaluation Notation

In the examples in this manual, results from expressions that you evaluate are indicated with `'=>'`. For example,

```
sqrt (2)
=> 1.4142
```

You can read this as “`sqrt (2)` evaluates to 1.4142”.

In some cases, matrix values that are returned by expressions are displayed like this

```
[1, 2; 3, 4] == [1, 3; 2, 4]
=> [ 1, 0; 0, 1 ]
```

and in other cases, they are displayed like this

```
eye (3)
⇒  1  0  0
    0  1  0
    0  0  1
```

in order to clearly show the structure of the result.

Sometimes to help describe one expression, another expression is shown that produces identical results. The exact equivalence of expressions is indicated with ‘ \equiv ’. For example,

```
rot90 ([1, 2; 3, 4], -1)
≡
rot90 ([1, 2; 3, 4], 3)
≡
rot90 ([1, 2; 3, 4], 7)
```

1.3.3 Printing Notation

Many of the examples in this manual print text when they are evaluated. Examples in this manual indicate printed text with ‘ \dashv ’. The value that is returned by evaluating the expression (here 1) is displayed with ‘ \Rightarrow ’ and follows on a separate line.

```
printf ("foo %s\n", "bar")
  ⍊ foo bar
⇒  1
```

1.3.4 Error Messages

Some examples signal errors. This normally displays an error message on your terminal. Error messages are shown on a line starting with **error:**.

```
struct_elements ([1, 2; 3, 4])
error: struct_elements: wrong type argument ‘matrix’
```

1.3.5 Format of Descriptions

Functions, commands, and variables are described in this manual in a uniform format. The first line of a description contains the name of the item followed by its arguments, if any. The category—function, variable, or whatever—is printed next to the right margin. The description follows on succeeding lines, sometimes with examples.

1.3.5.1 A Sample Function Description

In a function description, the name of the function being described appears first. It is followed on the same line by a list of parameters. The names used for the parameters are also used in the body of the description.

Here is a description of an imaginary function **foo**:

```
foo (x, y, ...) Function
  The function foo subtracts x from y, then adds the remaining arguments to the result.
  If y is not supplied, then the number 19 is used by default.
```

```
foo (1, [3, 5], 3, 9)
    => [ 14, 16 ]
foo (5)
    => 14
```

More generally,

```
foo (w, x, y, ...)
≡
x - w + y + ...
```

Any parameter whose name contains the name of a type (e.g., *integer*, *integer1* or *matrix*) is expected to be of that type. Parameters named *object* may be of any type. Parameters with other sorts of names (e.g., *new_file*) are discussed specifically in the description of the function. In some sections, features common to parameters of several functions are described at the beginning.

Functions in Octave may be defined in several different ways. The category name for functions may include another name that indicates the way that the function is defined. These additional tags include

Built-in Function

The function described is written in a language like C++, C, or Fortran, and is part of the compiled Octave binary.

Loadable Function

The function described is written in a language like C++, C, or Fortran. On systems that support dynamic linking of user-supplied functions, it may be automatically linked while Octave is running, but only if it is needed. See Section 13.8 [Dynamically Linked Functions], page 100.

Function File

The function described is defined using Octave commands stored in a text file. See Section 13.6 [Function Files], page 96.

Mapping Function

The function described works element-by-element for matrix and vector arguments.

1.3.5.2 A Sample Command Description

Command descriptions have a format similar to function descriptions, except that the word ‘Function’ is replaced by ‘Command. Commands are functions that may called without surrounding their arguments in parentheses. For example, here is the description for Octave’s `cd` command:

```
cd dir Command
chdir dir Command
```

Change the current working directory to *dir*. For example, `cd ~/octave` changes the current working directory to ‘~/octave’. If the directory does not exist, an error message is printed and the working directory is not changed.

1.3.5.3 A Sample Variable Description

A *variable* is a name that can hold a value. Although any variable can be set by the user, *built-in variables* typically exist specifically so that users can change them to alter the way Octave behaves (built-in variables are also sometimes called *user options*). Ordinary variables and built-in variables are described using a format like that for functions except that there are no arguments.

Here is a description of the imaginary variable `do_what_i_mean_not_what_i_say`.

do_what_i_mean_not_what_i_say

Built-in Variable

If the value of this variable is nonzero, Octave will do what you actually wanted, even if you have typed a completely different and meaningless list of commands.

Other variable descriptions have the same format, but ‘Built-in Variable’ is replaced by ‘Variable’, for ordinary variables, or ‘Constant’ for symbolic constants whose values cannot be changed.

2 Getting Started

This chapter explains some of Octave's basic features, including how to start an Octave session, get help at the command prompt, edit the command line, and write Octave programs that can be executed as commands from your shell.

2.1 Invoking Octave

Normally, Octave is used interactively by running the program 'octave' without any arguments. Once started, Octave reads commands from the terminal until you tell it to exit.

You can also specify the name of a file on the command line, and Octave will read and execute the commands from the named file and then exit when it is finished.

You can further control how Octave starts by using the command-line options described in the next section, and Octave itself can remind you of the options available. Type 'octave --help' to display all available options and briefly describe their use ('octave -h' is a shorter equivalent).

2.1.1 Command Line Options

Here is a complete list of all the command line options that Octave accepts.

- `--debug`
- `-d` Enter parser debugging mode. Using this option will cause Octave's parser to print a lot of information about the commands it reads, and is probably only useful if you are actually trying to debug the parser.
- `--echo-commands`
- `-x` Echo commands as they are executed.
- `--exec-path path`
Specify the path to search for programs to run. The value of *path* specified on the command line will override any value of `OCTAVE_EXEC_PATH` found in the environment, but not any commands in the system or user startup files that set the built-in variable `EXEC_PATH`.
- `--help`
- `-h`
- `-?` Print short help message and exit.
- `--info-file filename`
Specify the name of the info file to use. The value of *filename* specified on the command line will override any value of `OCTAVE_INFO_FILE` found in the environment, but not any commands in the system or user startup files that set the built-in variable `INFO_FILE`.
- `--info-program program`
Specify the name of the info program to use. The value of *program* specified on the command line will override any value of `OCTAVE_INFO_PROGRAM` found in the environment, but not any commands in the system or user startup files that set the built-in variable `INFO_PROGRAM`.

```

--interactive
-i          Force interactive behavior. This can be useful for running Octave via a remote
           shell command or inside an Emacs shell buffer. For another way to run Octave
           within Emacs, see Appendix D [Emacs], page 335.

--no-history
-H          Disable command-line history.

--no-init-file
           Don't read the '~/.octaverc' or '.octaverc' files.

--no-line-editing
           Disable command-line editing.

--no-site-file
           Don't read the site-wide 'octaverc' file.

--norc
-f          Don't read any of the system or user initialization files at startup. This is
           equivalent to using both of the options --no-init-file and --no-site-file.

--path path
-p path   Specify the path to search for function files. The value of path specified on the
           command line will override any value of OCTAVE_PATH found in the environment,
           but not any commands in the system or user startup files that set the built-in
           variable LOADPATH.

--silent
--quiet
-q          Don't print the usual greeting and version message at startup.

--traditional
--braindead
           Set initial values for user-preference variables to the following values for com-
           patibility with MATLAB.
           PS1                = ">> "
           PS2                = ""
           beep_on_error       = true
           crash_dumps_octave_core = false
           default_save_format = "mat-binary"
           fixed_point_format  = true
           page_screen_output  = false
           print_empty_dimensions = false
           warn_function_name_clash = false

--verbose
-V          Turn on verbose output.

--version
-v          Print the program version number and exit.

file      Execute commands from file.

```

Octave also includes several built-in variables that contain information about the command line, including the number of arguments and all of the options.

argv Built-in Variable

The command line arguments passed to Octave are available in this variable. For example, if you invoked Octave using the command

```
octave --no-line-editing --silent
```

`argv` would be a cell array of strings with the elements `--no-line-editing` and `--silent`.

If you write an executable Octave script, `argv` will contain the list of arguments passed to the script. See Section 2.6 [Executable Octave Programs], page 25, for an example of how to create an executable Octave script.

program_invocation_name Built-in Variable

program_name Built-in Variable

When Octave starts, the value of the built-in variable `program_invocation_name` is automatically set to the name that was typed at the shell prompt to run Octave, and the value of `program_name` is automatically set to the final component of `program_invocation_name`. For example, if you typed `‘/usr/local/bin/octave’` to start Octave, `program_invocation_name` would have the value `"/usr/local/bin/octave"`, and `program_name` would have the value `"octave"`.

If executing a script from the command line (e.g., `octave foo.m`) or using an executable Octave script, the program name is set to the name of the script. See Section 2.6 [Executable Octave Programs], page 25, for an example of how to create an executable Octave script.

Here is an example of using these variables to reproduce Octave’s command line.

```
printf ("%s", program_name);
for i = 1:nargin
    printf (" %s", nth (argv, i));
endfor
printf ("\n");
```

See Section 10.1 [Index Expressions], page 65, for an explanation of how to properly index arrays of strings and substrings in Octave, and See Section 13.1 [Defining Functions], page 91, for information about the variable `nargin`.

2.1.2 Startup Files

When Octave starts, it looks for commands to execute from the following files:

octave-home/share/octave/site/m/startup/octaverc

Where *octave-home* is the directory in which all of Octave is installed (the default is `‘/usr/local’`). This file is provided so that changes to the default Octave environment can be made globally for all users at your site for all versions of Octave you have installed. Some care should be taken when making changes to this file, since all users of Octave at your site will be affected.

octave-home/share/octave/version/m/startup/octaverc

Where *octave-home* is the directory in which all of Octave is installed (the default is `‘/usr/local’`), and *version* is the version number of Octave. This

file is provided so that changes to the default Octave environment can be made globally for all users for a particular version of Octave. Some care should be taken when making changes to this file, since all users of Octave at your site will be affected.

`~/.octaverc`

This file is normally used to make personal changes to the default Octave environment.

`.octaverc`

This file can be used to make changes to the default Octave environment for a particular project. Octave searches for this file in the current directory after it reads ‘`~/.octaverc`’. Any use of the `cd` command in the ‘`~/.octaverc`’ file will affect the directory that Octave searches for the file ‘`.octaverc`’.

If you start Octave in your home directory, commands from from the file ‘`~/.octaverc`’ will only be executed once.

A message will be displayed as each of the startup files is read if you invoke Octave with the `--verbose` option but without the `--silent` option.

Startup files may contain any valid Octave commands, including function definitions.

2.2 Quitting Octave

exit (*status*) Built-in Function
quit (*status*) Built-in Function

Exit the current Octave session. If the optional integer value *status* is supplied, pass that value to the operating system as the Octave’s exit status.

atexit (*fcn*) Built-in Function

Register a function to be called when Octave exits. For example,

```
function print_fortune ()
  printf ("\n%s\n", system ("fortune"));
  fflush (stdout);
endfunction
atexit ("print_fortune");
```

will print a message when Octave exits.

2.3 Commands for Getting Help

The entire text of this manual is available from the Octave prompt via the command `help -i`. In addition, the documentation for individual user-written functions and variables is also available via the `help` command. This section describes the commands used for reading the manual and the documentation strings for user-supplied functions and variables. See Section 13.6 [Function Files], page 96, for more information about how to document the functions you write.

help Command

Octave's `help` command can be used to print brief usage-style messages, or to display information directly from an on-line version of the printed manual, using the GNU Info browser. If invoked without any arguments, `help` prints a list of all the available operators, functions, and built-in variables. If the first argument is `-i`, the `help` command searches the index of the on-line version of this manual for the given topics.

For example, the command `help help` prints a short message describing the `help` command, and `help -i help` starts the GNU Info browser at this node in the on-line version of the manual.

Once the GNU Info browser is running, help for using it is available using the command `C-h`.

The `help` command can give you information about operators, but not the comma and semicolons that are used as command separators. To get help for those, you must type `help comma` or `help semicolon`.

INFO_FILE Built-in Variable

The variable `INFO_FILE` names the location of the Octave info file. The default value is "`octave-home/info/octave.info`", in which `octave-home` is the directory where all of Octave is installed.

INFO_PROGRAM Built-in Variable

The variable `INFO_PROGRAM` names the info program to run. Its default initial value is "`octave-home/libexec/octave/version/exec/arch/info`" in which `octave-home` is the directory where all of Octave is installed, `version` is the Octave version number, and `arch` is the system type (for example, `i686-pc-linux-gnu`). The default initial value may be overridden by the environment variable `OCTAVE_INFO_PROGRAM`, or the command line argument `--info-program NAME`, or by setting the value of `INFO_PROGRAM` in a startup script

MAKEINFO_PROGRAM Built-in Variable

The variable `MAKEINFO_PROGRAM` names the `makeinfo` program that Octave runs to format help text that contains Texinfo markup commands. Its default initial value is "`makeinfo`".

suppress_verbose_help_message Built-in Variable

If the value of `suppress_verbose_help_message` is nonzero, Octave will not add additional help information to the end of the output from the `help` command and usage messages for built-in commands.

2.4 Command Line Editing

Octave uses the GNU readline library to provide an extensive set of command-line editing and history features. Only the most common features are described in this manual. Please see The GNU Readline Library manual for more information.

To insert printing characters (letters, digits, symbols, etc.), simply type the character. Octave will insert the character at the cursor and advance the cursor forward.

Many of the command-line editing functions operate using control characters. For example, the character *Control-a* moves the cursor to the beginning of the line. To type *C-a*, hold down `CTRL` and then press `a`. In the following sections, control characters such as *Control-a* are written as *C-a*.

Another set of command-line editing functions use Meta characters. On some terminals, you type *M-u* by holding down `META` and pressing `u`. If your terminal does not have a `META` key, you can still type Meta characters using two-character sequences starting with *ESC*. Thus, to enter *M-u*, you could type `ESC u`. The *ESC* character sequences are also allowed on terminals with real Meta keys. In the following sections, Meta characters such as *Meta-u* are written as *M-u*.

2.4.1 Cursor Motion

The following commands allow you to position the cursor.

<i>C-b</i>	Move back one character.
<i>C-f</i>	Move forward one character.
<code>DEL</code>	Delete the character to the left of the cursor.
<i>C-d</i>	Delete the character underneath the cursor.
<i>M-f</i>	Move forward a word.
<i>M-b</i>	Move backward a word.
<i>C-a</i>	Move to the start of the line.
<i>C-e</i>	Move to the end of the line.
<i>C-l</i>	Clear the screen, reprinting the current line at the top.
<i>C-_</i>	
<i>C-/</i>	Undo the last thing that you did. You can undo all the way back to an empty line.
<i>M-r</i>	Undo all changes made to this line. This is like typing the ‘undo’ command enough times to get back to the beginning.

The above table describes the most basic possible keystrokes that you need in order to do editing of the input line. On most terminals, you can also use the arrow keys in place of *C-f* and *C-b* to move forward and backward.

Notice how *C-f* moves forward a character, while *M-f* moves forward a word. It is a loose convention that control keystrokes operate on characters while meta keystrokes operate on words.

There is also a function available so that you can clear the screen from within Octave programs.

clc ()	Built-in Function
home ()	Built-in Function
Clear the terminal screen and move the cursor to the upper left corner.	

2.4.2 Killing and Yanking

Killing text means to delete the text from the line, but to save it away for later use, usually by *yanking* it back into the line. If the description for a command says that it ‘kills’ text, then you can be sure that you can get the text back in a different (or the same) place later.

Here is the list of commands for killing text.

C-k	Kill the text from the current cursor position to the end of the line.
M-d	Kill from the cursor to the end of the current word, or if between words, to the end of the next word.
M-<u>DEL</u>	Kill from the cursor to the start of the previous word, or if between words, to the start of the previous word.
C-w	Kill from the cursor to the previous whitespace. This is different than M-<u>DEL</u> because the word boundaries differ.

And, here is how to *yank* the text back into the line. Yanking means to copy the most-recently-killed text from the kill buffer.

C-y	Yank the most recently killed text back into the buffer at the cursor.
M-y	Rotate the kill-ring, and yank the new top. You can only do this if the prior command is C-y or M-y .

When you use a kill command, the text is saved in a *kill-ring*. Any number of consecutive kills save all of the killed text together, so that when you yank it back, you get it in one clean sweep. The kill ring is not line specific; the text that you killed on a previously typed line is available to be yanked back later, when you are typing another line.

2.4.3 Commands For Changing Text

The following commands can be used for entering characters that would otherwise have a special meaning (e.g., **TAB**, **C-q**, etc.), or for quickly correcting typing mistakes.

C-q	
C-v	Add the next character that you type to the line verbatim. This is how to insert things like C-q for example.
M-<u>TAB</u>	Insert a tab character.
C-t	Drag the character before the cursor forward over the character at the cursor, also moving the cursor forward. If the cursor is at the end of the line, then transpose the two characters before it.
M-t	Drag the word behind the cursor past the word in front of the cursor moving the cursor over that word as well.

- M-u* Uppercase the characters following the cursor to the end of the current (or following) word, moving the cursor to the end of the word.
- M-l* Lowecase the characters following the cursor to the end of the current (or following) word, moving the cursor to the end of the word.
- M-c* Uppercase the character following the cursor (or the beginning of the next word if the cursor is between words), moving the cursor to the end of the word.

2.4.4 Letting Readline Type For You

The following commands allow Octave to complete command and variable names for you.

- TAB Attempt to do completion on the text before the cursor. Octave can complete the names of commands and variables.
- M-?* List the possible completions of the text before the cursor.

completion_append_char Built-in Variable

The value of `completion_append_char` is used as the character to append to successful command-line completion attempts. The default value is " " (a single space).

completion_matches (*hint*) Built-in Function

Generate possible completions given *hint*.

This function is provided for the benefit of programs like Emacs which might be controlling Octave and handling user input. The current command number is not incremented when this function is called. This is a feature, not a bug.

2.4.5 Commands For Manipulating The History

Octave normally keeps track of the commands you type so that you can recall previous commands to edit or execute them again. When you exit Octave, the most recent commands you have typed, up to the number specified by the variable `history_size`, are saved in a file. When Octave starts, it loads an initial list of commands from the file named by the variable `history_file`.

Here are the commands for simple browsing and searching the history list.

- LFD
- RET Accept the line regardless of where the cursor is. If this line is non-empty, add it to the history list. If this line was a history line, then restore the history line to its original state.
- C-p* Move ‘up’ through the history list.
- C-n* Move ‘down’ through the history list.
- M-<* Move to the first line in the history.
- M->* Move to the end of the input history, i.e., the line you are entering!

- C-r** Search backward starting at the current line and moving ‘up’ through the history as necessary. This is an incremental search.
- C-s** Search forward starting at the current line and moving ‘down’ through the history as necessary.

On most terminals, you can also use the arrow keys in place of **C-p** and **C-n** to move through the history list.

In addition to the keyboard commands for moving through the history list, Octave provides three functions for viewing, editing, and re-running chunks of commands from the history list.

history *options* Command

If invoked with no arguments, **history** displays a list of commands that you have executed. Valid options are:

- w file** Write the current history to the file *file*. If the name is omitted, use the default history file (normally ‘`~/octave_hist`’).
- r file** Read the file *file*, replacing the current history list with its contents. If the name is omitted, use the default history file (normally ‘`~/octave_hist`’).
- n** Only display the most recent *n* lines of history.
- q** Don’t number the displayed lines of history. This is useful for cutting and pasting commands if you are using the X Window System.

For example, to display the five most recent commands that you have typed without displaying line numbers, use the command **history -q 5**.

edit_history *options* Command

If invoked with no arguments, **edit_history** allows you to edit the history list using the editor named by the variable **EDITOR**. The commands to be edited are first copied to a temporary file. When you exit the editor, Octave executes the commands that remain in the file. It is often more convenient to use **edit_history** to define functions rather than attempting to enter them directly on the command line. By default, the block of commands is executed as soon as you exit the editor. To avoid executing any commands, simply delete all the lines from the buffer before exiting the editor.

The **edit_history** command takes two optional arguments specifying the history numbers of first and last commands to edit. For example, the command

```
edit_history 13
```

extracts all the commands from the 13th through the last in the history list. The command

```
edit_history 13 169
```

only extracts commands 13 through 169. Specifying a larger number for the first command than the last command reverses the list of commands before placing them in the buffer to be edited. If both arguments are omitted, the previous command in the history list is used.

run_history [*first*] [*last*] Command
 Similar to `edit_history`, except that the editor is not invoked, and the commands are simply executed as they appear in the history list.

EDITOR Built-in Variable
 A string naming the editor to use with the `edit_history` command. If the environment variable `EDITOR` is set when Octave starts, its value is used as the default. Otherwise, `EDITOR` is set to `"emacs"`.

history_file Built-in Variable
 This variable specifies the name of the file used to store command history. The default value is `"~/octave_hist"`, but may be overridden by the environment variable `OCTAVE_HISTFILE`.

history_size Built-in Variable
 This variable specifies how many entries to store in the history file. The default value is 1024, but may be overridden by the environment variable `OCTAVE_HISTSIZE`.

saving_history Built-in Variable
 If the value of `saving_history` is nonzero, command entered on the command line are saved in the file specified by the variable `history_file`.

2.4.6 Customizing readline

read_readline_init_file (*file*) Built-in Function
 Read the readline library initialization file *file*. If *file* is omitted, read the default initialization file (normally `'~/inputrc'`).

2.4.7 Customizing the Prompt

The following variables are available for customizing the appearance of the command-line prompts. Octave allows the prompt to be customized by inserting a number of backslash-escaped special characters that are decoded as follows:

<code>'\t'</code>	The time.
<code>'\d'</code>	The date.
<code>'\n'</code>	Begins a new line by printing the equivalent of a carriage return followed by a line feed.
<code>'\s'</code>	The name of the program (usually just <code>'octave'</code>).
<code>'\w'</code>	The current working directory.
<code>'\W'</code>	The basename of the current working directory.
<code>'\u'</code>	The username of the current user.

<code>'\h'</code>	The hostname, up to the first <code>'.'</code> .
<code>'\H'</code>	The hostname.
<code>'\#'</code>	The command number of this command, counting from when Octave starts.
<code>'\!'</code>	The history number of this command. This differs from <code>'\#'</code> by the number of commands in the history list when Octave starts.
<code>'\\$'</code>	If the effective UID is 0, a <code>'#'</code> , otherwise a <code>'\$'</code> .
<code>'\nnn'</code>	The character whose character code in octal is <i>nnn</i> .
<code>'\'</code>	A backslash.

PS1

Built-in Variable

The primary prompt string. When executing interactively, Octave displays the primary prompt `PS1` when it is ready to read a command.

The default value of `PS1` is `"\s:\#> "`. To change it, use a command like

```
octave:13> PS1 = "\\u@\\H> "
```

which will result in the prompt `'boris@kremvax>'` for the user `'boris'` logged in on the host `'kremvax.kgb.su'`. Note that two backslashes are required to enter a backslash into a string. See Chapter 5 [Strings], page 39.

PS2

Built-in Variable

The secondary prompt string, which is printed when Octave is expecting additional input to complete a command. For example, when defining a function over several lines, Octave will print the value of `PS1` at the beginning of each line after the first.

The default value of `PS2` is `"> "`.

PS4

Built-in Variable

If Octave is invoked with the `--echo-commands` option, the value of `PS4` is printed before each line of input that is echoed. The default value of `PS4` is `"+"`. See Section 2.1 [Invoking Octave], page 13, for a description of `--echo-commands`.

2.4.8 Diary and Echo Commands

Octave's diary feature allows you to keep a log of all or part of an interactive session by recording the input you type and the output that Octave produces in a separate file.

diary options

Command

Create a list of all commands *and* the output they produce, mixed together just as you see them on your terminal. Valid options are:

on Start recording your session in a file called `'diary'` in your current working directory.

off Stop recording your session in the diary file.

file Record your session in the file named *file*.

Without any arguments, `diary` toggles the current diary state.

Sometimes it is useful to see the commands in a function or script as they are being evaluated. This can be especially helpful for debugging some kinds of problems.

echo *options* Command

Control whether commands are displayed as they are executed. Valid options are:

- on** Enable echoing of commands as they are executed in script files.
- off** Disable echoing of commands as they are executed in script files.
- on all** Enable echoing of commands as they are executed in script files and functions.
- off all** Disable echoing of commands as they are executed in script files and functions.

If invoked without any arguments, **echo** toggles the current echo state.

echo_executing_commands Built-in Variable

This variable may also be used to control the echo state. It may be the sum of the following values:

- 1 Echo commands read from script files.
- 2 Echo commands from functions.
- 4 Echo commands read from command line.

More than one state can be active at once. For example, a value of 3 is equivalent to the command **echo on all**.

The value of **echo_executing_commands** is set by the **echo** command and the command line option **--echo-input**.

2.5 How Octave Reports Errors

Octave reports two kinds of errors for invalid programs.

A *parse error* occurs if Octave cannot understand something you have typed. For example, if you misspell a keyword,

```
octave:13> functon y = f (x) y = x^2; endfunction
```

Octave will respond immediately with a message like this:

```
parse error:
```

```
function y = f (x) y = x^2; endfunction
      ^
```

For most parse errors, Octave uses a caret (^) to mark the point on the line where it was unable to make sense of your input. In this case, Octave generated an error message because the keyword **function** was misspelled. Instead of seeing **'function f'**, Octave saw two consecutive variable names, which is invalid in this context. It marked the error at **y** because the first name by itself was accepted as valid input.

Another class of error message occurs at evaluation time. These errors are called *run-time errors*, or sometimes *evaluation errors* because they occur when your program is being *run*, or *evaluated*. For example, if after correcting the mistake in the previous function definition, you type

```
octave:13> f ()
```

Octave will respond with

```
error: 'x' undefined near line 1 column 24
error: evaluating expression near line 1, column 24
error: evaluating assignment expression near line 1, column 22
error: called from 'f'
```

This error message has several parts, and gives you quite a bit of information to help you locate the source of the error. The messages are generated from the point of the innermost error, and provide a traceback of enclosing expressions and function calls.

In the example above, the first line indicates that a variable named 'x' was found to be undefined near line 1 and column 24 of some function or expression. For errors occurring within functions, lines are counted from the beginning of the file containing the function definition. For errors occurring at the top level, the line number indicates the input line number, which is usually displayed in the prompt string.

The second and third lines in the example indicate that the error occurred within an assignment expression, and the last line of the error message indicates that the error occurred within the function `f`. If the function `f` had been called from another function, for example, `g`, the list of errors would have ended with one more line:

```
error: called from 'g'
```

These lists of function calls usually make it fairly easy to trace the path your program took before the error occurred, and to correct the error before trying again.

2.6 Executable Octave Programs

Once you have learned Octave, you may want to write self-contained Octave scripts, using the '#' script mechanism. You can do this on GNU systems and on many Unix systems¹

For example, you could create a text file named 'hello', containing the following lines:

```
#! octave-interpreter-name -qf
# a sample Octave program
printf ("Hello, world!\n");
```

(where *octave-interpreter-name* should be replaced with the full file name for your Octave binary). After making this file executable (with the `chmod` command), you can simply type:

```
hello
```

at the shell, and the system will arrange to run Octave as if you had typed:

```
octave hello
```

The line beginning with '#' lists the full file name of an interpreter to be run, and an optional initial command line argument to pass to that interpreter. The operating system

¹ The '#' mechanism works on Unix systems derived from Berkeley Unix, System V Release 4, and some System V Release 3 systems.

then runs the interpreter with the given argument and the full argument list of the executed program. The first argument in the list is the full file name of the Octave program. The rest of the argument list will either be options to Octave, or data files, or both. The ‘-qf’ option is usually specified in stand-alone Octave programs to prevent them from printing the normal startup message, and to keep them from behaving differently depending on the contents of a particular user’s ‘~/octaverc’ file. See Section 2.1 [Invoking Octave], page 13. Note that some operating systems may place a limit on the number of characters that are recognized after ‘#!’.

Self-contained Octave scripts are useful when you want to write a program which users can invoke without knowing that the program is written in the Octave language.

If you invoke an executable Octave script with command line arguments, the arguments are available in the built-in variable `argv`. See Section 2.1.1 [Command Line Options], page 13. For example, the following program will reproduce the command line that is used to execute it.

```
#! /bin/octave -qf
printf ("%s", program_name);
for i = 1:nargin
    printf (" %s", argv{i});
endfor
printf ("\n");
```

2.7 Comments in Octave Programs

A *comment* is some text that is included in a program for the sake of human readers, and that is not really part of the program. Comments can explain what the program does, and how it works. Nearly all programming languages have provisions for comments, because programs are typically hard to understand without them.

In the Octave language, a comment starts with either the sharp sign character, ‘#’, or the percent symbol ‘%’ and continues to the end of the line. The Octave interpreter ignores the rest of a line following a sharp sign or percent symbol. For example, we could have put the following into the function `f`:

```
function xdot = f (x, t)

# usage: f (x, t)
#
# This function defines the right hand
# side functions for a set of nonlinear
# differential equations.

r = 0.25;
...
endfunction
```

The `help` command (see Section 2.3 [Getting Help], page 16) is able to find the first block of comments in a function (even those that are composed directly on the command line). This means that users of Octave can use the same commands to get help for built-in functions, and for functions that you have defined. For example, after defining the function `f` above, the command `help f` produces the output

```
usage: f (x, t)
```

```
This function defines the right hand  
side functions for a set of nonlinear  
differential equations.
```

Although it is possible to put comment lines into keyboard-composed throw-away Octave programs, it usually isn't very useful, because the purpose of a comment is to help you or another person understand the program at a later time.

3 Data Types

All versions of Octave include a number of built-in data types, including real and complex scalars and matrices, character strings, and a data structure type.

It is also possible to define new specialized data types by writing a small amount of C++ code. On some systems, new data types can be loaded dynamically while Octave is running, so it is not necessary to recompile all of Octave just to add a new type. See Section 13.8 [Dynamically Linked Functions], page 100, for more information about Octave's dynamic linking capabilities. Section 3.2 [User-defined Data Types], page 30 describes what you must do to define a new data type for Octave.

typeinfo (*expr*) Built-in Function
 Return the type of the expression *expr*, as a string. If *EXPR* is omitted, return an array of strings containing all the currently installed data types.

3.1 Built-in Data Types

The standard built-in data types are real and complex scalars and matrices, ranges, character strings, and a data structure type. Additional built-in data types may be added in future versions. If you need a specialized data type that is not currently provided as a built-in type, you are encouraged to write your own user-defined data type and contribute it for distribution in a future release of Octave.

3.1.1 Numeric Objects

Octave's built-in numeric objects include real and complex scalars and matrices. All built-in numeric data is currently stored as double precision numbers. On systems that use the IEEE floating point format, values in the range of approximately 2.2251×10^{-308} to 1.7977×10^{308} can be stored, and the relative precision is approximately 2.2204×10^{-16} . The exact values are given by the variables `realmin`, `realmax`, and `eps`, respectively.

Matrix objects can be of any size, and can be dynamically reshaped and resized. It is easy to extract individual rows, columns, or submatrices using a variety of powerful indexing features. See Section 10.1 [Index Expressions], page 65.

See Chapter 4 [Numeric Data Types], page 33, for more information.

3.1.2 Missing Data

NA Built-in Variable
 Missing value.

isna (*x*) Mapping Function
 Return 1 for elements of *x* that are NA (missing) values and zero otherwise. For example,

```
is_NA ([13, Inf, NA, NaN])
⇒ [ 0, 0, 1, 0 ]
```

is_nan_or_na (*x*) Mapping Function

Return 1 for elements of *x* that are NaN or NA (missing) values and zero otherwise.

For example,

```
is_NAN_or_NA ([13, Inf, NA, NaN])
⇒ [ 0, 0, 1, 1 ]
```

3.1.3 String Objects

A character string in Octave consists of a sequence of characters enclosed in either double-quote or single-quote marks. Internally, Octave currently stores strings as matrices of characters. All the indexing operations that work for matrix objects also work for strings.

See Chapter 5 [Strings], page 39, for more information.

3.1.4 Data Structure Objects

Octave's data structure type can help you to organize related objects of different types. The current implementation uses an associative array with indices limited to strings, but the syntax is more like C-style structures.

See Chapter 6 [Data Structures], page 47, for more information.

3.2 User-defined Data Types

Someday I hope to expand this to include a complete description of Octave's mechanism for managing user-defined data types. Until this feature is documented here, you will have to make do by reading the code in the 'ov.h', 'ops.h', and related files from Octave's 'src' directory.

3.3 Object Sizes

The following functions allow you to determine the size of a variable or expression. These functions are defined for all objects. They return -1 when the operation doesn't make sense. For example, Octave's data structure type doesn't have rows or columns, so the `rows` and `columns` functions return -1 for structure arguments.

columns (*a*) Function File

Return the number of columns of *a*.

rows (*a*) Function File

Return the number of rows of *a*.

length (*a*) Built-in Function

Return the 'length' of the object *a*. For matrix objects, the length is the number of rows or columns, whichever is greater (this odd definition is used for compatibility with Matlab).

size (*a*, *n*)

Built-in Function

Return the number rows and columns of *a*.

With one input argument and one output argument, the result is returned in a row vector. If there are multiple output arguments, the number of rows is assigned to the first, and the number of columns to the second, etc. For example,

```
size ([1, 2; 3, 4; 5, 6])  
⇒ [ 3, 2 ]
```

```
[nr, nc] = size ([1, 2; 3, 4; 5, 6])  
⇒ nr = 3  
⇒ nc = 2
```

If given a second argument, **size** will return the size of the corresponding dimension. For example

```
size ([1, 2; 3, 4; 5, 6], 2)  
⇒ 2
```

returns the number of columns in the given matrix.

isempty (*a*)

Built-in Function

Return 1 if *a* is an empty matrix (either the number of rows, or the number of columns, or both are zero). Otherwise, return 0.

4 Numeric Data Types

A *numeric constant* may be a scalar, a vector, or a matrix, and it may contain complex values.

The simplest form of a numeric constant, a scalar, is a single number that can be an integer, a decimal fraction, a number in scientific (exponential) notation, or a complex number. Note that all numeric constants are represented within Octave in double-precision floating point format (complex constants are stored as pairs of double-precision floating point values). Here are some examples of real-valued numeric constants, which all have the same value:

```
105
1.05e+2
1050e-1
```

To specify complex constants, you can write an expression of the form

```
3 + 4i
3.0 + 4.0i
0.3e1 + 40e-1i
```

all of which are equivalent. The letter ‘i’ in the previous example stands for the pure imaginary constant, defined as $\sqrt{-1}$.

For Octave to recognize a value as the imaginary part of a complex constant, a space must not appear between the number and the ‘i’. If it does, Octave will print an error message, like this:

```
octave:13> 3 + 4 i

parse error:

3 + 4 i
      ^
```

You may also use ‘j’, ‘I’, or ‘J’ in place of the ‘i’ above. All four forms are equivalent.

4.1 Matrices

It is easy to define a matrix of values in Octave. The size of the matrix is determined automatically, so it is not necessary to explicitly state the dimensions. The expression

```
a = [1, 2; 3, 4]
```

results in the matrix

$$a = \begin{bmatrix} 1 & 2 \\ 3 & 4 \end{bmatrix}$$

Elements of a matrix may be arbitrary expressions, provided that the dimensions all make sense when combining the various pieces. For example, given the above matrix, the expression

```
[ a, a ]
```

produces the matrix

```
ans =
    1  2  1  2
    3  4  3  4
```

but the expression

```
[ a, 1 ]
```

produces the error

```
error: number of rows must match near line 13, column 6
```

(assuming that this expression was entered as the first thing on line 13, of course).

Inside the square brackets that delimit a matrix expression, Octave looks at the surrounding context to determine whether spaces and newline characters should be converted into element and row separators, or simply ignored, so an expression like

```
a = [ 1 2
      3 4 ]
```

will work. However, some possible sources of confusion remain. For example, in the expression

```
[ 1 - 1 ]
```

the ‘-’ is treated as a binary operator and the result is the scalar 0, but in the expression

```
[ 1 -1 ]
```

the ‘-’ is treated as a unary operator and the result is the vector [1, -1]. Similarly, the expression

```
[ sin (pi) ]
```

will be parsed as

```
[ sin, (pi) ]
```

and will result in an error since the `sin` function will be called with no arguments. To get around this, you must omit the space between `sin` and the opening parenthesis, or enclose the expression in a set of parentheses:

```
[ (sin (pi)) ]
```

Whitespace surrounding the single quote character (‘’’, used as a transpose operator and for delimiting character strings) can also cause confusion. Given `a = 1`, the expression

```
[ 1 a' ]
```

results in the single quote character being treated as a transpose operator and the result is the vector [1, 1], but the expression

```
[ 1 a ' ]
```

produces the error message

```
error: unterminated string constant
```

because to not do so would cause trouble when parsing the valid expression

```
[ a 'foo' ]
```

For clarity, it is probably best to always use commas and semicolons to separate matrix elements and rows.

warn_separator_insert

Built-in Variable

Print warning if commas or semicolons might be inserted automatically in literal matrices.

When you type a matrix or the name of a variable whose value is a matrix, Octave responds by printing the matrix in with neatly aligned rows and columns. If the rows of the matrix are too large to fit on the screen, Octave splits the matrix and displays a header before each section to indicate which columns are being displayed. You can use the following variables to control the format of the output.

output_max_field_width

Built-in Variable

This variable specifies the maximum width of a numeric output field. The default value is 10.

output_precision

Built-in Variable

This variable specifies the minimum number of significant figures to display for numeric output. The default value is 5.

It is possible to achieve a wide range of output styles by using different values of `output_precision` and `output_max_field_width`. Reasonable combinations can be set using the `format` function. See Section 16.1 [Basic Input and Output], page 110.

split_long_rows

Built-in Variable

For large matrices, Octave may not be able to display all the columns of a given row on one line of your screen. This can result in missing information or output that is nearly impossible to decipher, depending on whether your terminal truncates or wraps long lines.

If the value of `split_long_rows` is nonzero, Octave will display the matrix in a series of smaller pieces, each of which can fit within the limits of your terminal width. Each set of rows is labeled so that you can easily see which columns are currently being displayed. For example:

```
octave:13> rand (2,10)
ans =

Columns 1 through 6:

    0.75883    0.93290    0.40064    0.43818    0.94958    0.16467
    0.75697    0.51942    0.40031    0.61784    0.92309    0.40201

Columns 7 through 10:

    0.90174    0.11854    0.72313    0.73326
    0.44672    0.94303    0.56564    0.82150
```

The default value of `split_long_rows` is nonzero.

Octave automatically switches to scientific notation when values become very large or very small. This guarantees that you will see several significant figures for every value in

a matrix. If you would prefer to see all values in a matrix printed in a fixed point format, you can set the built-in variable `fixed_point_format` to a nonzero value. But doing so is not recommended, because it can produce output that can easily be misinterpreted.

fixed_point_format

Built-in Variable

If the value of this variable is nonzero, Octave will scale all values in a matrix so that the largest may be written with one leading digit. The scaling factor is printed on the first line of output. For example,

```
octave:1> logspace (1, 7, 5)
ans =

    1.0e+07 *

    0.00000
    0.00003
    0.00100
    0.03162
    1.00000
```

Notice that first value appears to be zero when it is actually 1. For this reason, you should be careful when setting `fixed_point_format` to a nonzero value.

The default value of `fixed_point_format` is 0.

4.1.1 Empty Matrices

A matrix may have one or both dimensions zero, and operations on empty matrices are handled as described by Carl de Boer in *An Empty Exercise*, SIGNUM, Volume 25, pages 2–6, 1990 and C. N. Nett and W. M. Haddad, in *A System-Theoretic Appropriate Realization of the Empty Matrix Concept*, IEEE Transactions on Automatic Control, Volume 38, Number 5, May 1993. Briefly, given a scalar s , an $m \times n$ matrix $M_{m \times n}$, and an $m \times n$ empty matrix $[]_{m \times n}$ (with either one or both dimensions equal to zero), the following are true:

$$\begin{aligned} s \cdot []_{m \times n} &= []_{m \times n} \cdot s = []_{m \times n} \\ []_{m \times n} + []_{m \times n} &= []_{m \times n} \\ []_{0 \times m} \cdot M_{m \times n} &= []_{0 \times n} \\ M_{m \times n} \cdot []_{n \times 0} &= []_{m \times 0} \\ []_{m \times 0} \cdot []_{0 \times n} &= 0_{m \times n} \end{aligned}$$

By default, dimensions of the empty matrix are printed along with the empty matrix symbol, `[]`. The built-in variable `print_empty_dimensions` controls this behavior.

print_empty_dimensions

Built-in Variable

If the value of `print_empty_dimensions` is nonzero, the dimensions of empty matrices are printed along with the empty matrix symbol, `[]`. For example, the expression

```
zeros (3, 0)
```

will print

```
ans = [] (3x0)
```

Empty matrices may also be used in assignment statements as a convenient way to delete rows or columns of matrices. See Section 10.6 [Assignment Expressions], page 72.

warn_empty_list_elements Built-in Variable

If the value of `warn_empty_list_elements` is nonzero, print a warning when an empty matrix is found in a matrix list. For example,

```
a = [1, [], 3, [], 5]
```

The default value is 0.

When Octave parses a matrix expression, it examines the elements of the list to determine whether they are all constants. If they are, it replaces the list with a single matrix constant.

4.2 Ranges

A *range* is a convenient way to write a row vector with evenly spaced elements. A range expression is defined by the value of the first element in the range, an optional value for the increment between elements, and a maximum value which the elements of the range will not exceed. The base, increment, and limit are separated by colons (the ‘:’ character) and may contain any arithmetic expressions and function calls. If the increment is omitted, it is assumed to be 1. For example, the range

```
1 : 5
```

defines the set of values ‘[1, 2, 3, 4, 5]’, and the range

```
1 : 3 : 5
```

defines the set of values ‘[1, 4]’.

Although a range constant specifies a row vector, Octave does *not* convert range constants to vectors unless it is necessary to do so. This allows you to write a constant like ‘1 : 10000’ without using 80,000 bytes of storage on a typical 32-bit workstation.

Note that the upper (or lower, if the increment is negative) bound on the range is not always included in the set of values, and that ranges defined by floating point values can produce surprising results because Octave uses floating point arithmetic to compute the values in the range. If it is important to include the endpoints of a range and the number of elements is known, you should use the `linspace` function instead (see Section 18.3 [Special Utility Matrices], page 155).

When Octave parses a range expression, it examines the elements of the expression to determine whether they are all constants. If they are, it replaces the range expression with a single range constant.

4.3 Logical Values

true Built-in Variable

Logical true value.

false Built-in Variable

Logical false value.

4.4 Predicates for Numeric Objects

isnumeric (<i>x</i>)	Built-in Function
Return nonzero if <i>x</i> is a numeric object.	
isreal (<i>x</i>)	Built-in Function
Return true if <i>x</i> is a real-valued numeric object.	
iscomplex (<i>x</i>)	Built-in Function
Return true if <i>x</i> is a complex-valued numeric object.	
ismatrix (<i>a</i>)	Built-in Function
Return 1 if <i>a</i> is a matrix. Otherwise, return 0.	
isvector (<i>a</i>)	Function File
Return 1 if <i>a</i> is a vector. Otherwise, return 0.	
isscalar (<i>a</i>)	Function File
Return 1 if <i>a</i> is a scalar. Otherwise, return 0.	
issquare (<i>x</i>)	Function File
If <i>x</i> is a square matrix, then return the dimension of <i>x</i> . Otherwise, return 0.	
issymmetric (<i>x</i> , <i>tol</i>)	Function File
If <i>x</i> is symmetric within the tolerance specified by <i>tol</i> , then return the dimension of <i>x</i> . Otherwise, return 0. If <i>tol</i> is omitted, use a tolerance equal to the machine precision.	
isbool (<i>x</i>)	Built-in Function
Return true if <i>x</i> is a boolean object.	

5 Strings

A *string constant* consists of a sequence of characters enclosed in either double-quote or single-quote marks. For example, both of the following expressions

```
"parrot"
'parrot'
```

represent the string whose contents are ‘parrot’. Strings in Octave can be of any length.

Since the single-quote mark is also used for the transpose operator (see Section 10.3 [Arithmetic Ops], page 68) but double-quote marks have no other purpose in Octave, it is best to use double-quote marks to denote strings.

Some characters cannot be included literally in a string constant. You represent them instead with *escape sequences*, which are character sequences beginning with a backslash (‘\’).

One use of an escape sequence is to include a double-quote (single-quote) character in a string constant that has been defined using double-quote (single-quote) marks. Since a plain double-quote would end the string, you must use ‘\”’ to represent a single double-quote character as a part of the string. The backslash character itself is another character that cannot be included normally. You must write ‘\\’ to put one backslash in the string. Thus, the string whose contents are the two characters ‘\’ may be written “\”\” or ‘\’\’. Similarly, the string whose contents are the two characters ‘\’ may be written ‘\’\’ or “\”\”.

Another use of backslash is to represent unprintable characters such as newline. While there is nothing to stop you from writing most of these characters directly in a string constant, they may look ugly.

Here is a table of all the escape sequences used in Octave. They are the same as those used in the C programming language.

\\	Represents a literal backslash, ‘\’.
\"	Represents a literal double-quote character, ‘”’.
\’	Represents a literal single-quote character, ‘’’.
\0	Represents the “nul” character, control-@, ASCII code 0.
\a	Represents the “alert” character, control-g, ASCII code 7.
\b	Represents a backspace, control-h, ASCII code 8.
\f	Represents a formfeed, control-l, ASCII code 12.
\n	Represents a newline, control-j, ASCII code 10.
\r	Represents a carriage return, control-m, ASCII code 13.
\t	Represents a horizontal tab, control-i, ASCII code 9.
\v	Represents a vertical tab, control-k, ASCII code 11.

Strings may be concatenated using the notation for defining matrices. For example, the expression

```
[ "foo" , "bar" , "baz" ]
```

produces the string whose contents are ‘foobarbaz’. See Chapter 4 [Numeric Data Types], page 33, for more information about creating matrices.

5.1 Creating Strings

blanks (*n*) Function File

Return a string of *n* blanks.

char (*x*) Built-in Function

char (*cell_array*) Built-in Function

char (*s1, s2, ...*) Built-in Function

Create a string array from a numeric matrix, cell array, or list of

If the argument is a numeric matrix, each element of the matrix is converted to the corresponding ASCII character. For example,

```
char ([97, 98, 99])
⇒ "abc"
```

If the argument is a cell array of strings, the result is a string array with each element corresponding to one element of the cell array.

For multiple string arguments, the result is a string array with each element corresponding to the arguments.

The returned values are padded with blanks as needed to make each row of the string array have the same length.

int2str (*n*) Function File

num2str (*x, precision*) Function File

num2str (*x, format*) Function File

Convert a number to a string. These functions are not very flexible, but are provided for compatibility with MATLAB. For better control over the results, use `sprintf` (see Section 16.2.4 [Formatted Output], page 119).

com2str (*zz, flg*) Function File

This function has been deprecated. Use `num2str` instead.

Convert complex number to a string. **Inputs**

zz complex number

flg format flag 0 (default): -1, 0, 1, 1i, 1 + 0.5i 1 (for use with `zpout`): -1, 0, + 1, + 1i, + 1 + 0.5i

strcat (*s1, s2, ...*) Function File

Return a string containing all the arguments concatenated. For example,

```
s = [ "ab"; "cde" ];
strcat (s, s, s)
⇒ "ab ab ab "
      "cdecdecde"
```

string_fill_char

Built-in Variable

The value of this variable is used to pad all strings in a string matrix to the same length. It should be a single character. The default value is " " (a single space). For example,

```
string_fill_char = "X";
[ "these"; "are"; "strings" ]
⇒ "theseXX"
   "areXXXX"
   "strings"
```

str2mat (s_1, \dots, s_n)

Function File

Return a matrix containing the strings s_1, \dots, s_n as its rows. Each string is padded with blanks in order to form a valid matrix.

This function is modelled after MATLAB. In Octave, you can create a matrix of strings by $[s_1; \dots; s_n]$ even if the strings are not all the same length.

ischar (a)

Built-in Function

Return 1 if a is a string. Otherwise, return 0.

isstr (a)

Function File

This function has been deprecated. Use `ischar` instead.

5.2 Searching and Replacing

deblank (s)

Function File

Removes the trailing blanks and nulls from the string s . If s is a matrix, *deblank* trims each row to the length of longest string.

findstr ($s, t, overlap$)

Function File

Return the vector of all positions in the longer of the two strings s and t where an occurrence of the shorter of the two starts. If the optional argument *overlap* is nonzero, the returned vector can include overlapping positions (this is the default).

For example,

```
findstr ("ababab", "a")
⇒ [ 1, 3, 5 ]
findstr ("abababa", "aba", 0)
⇒ [ 1, 5 ]
```

index (s, t)

Function File

Return the position of the first occurrence of the string t in the string s , or 0 if no occurrence is found. For example,

```
index ("Teststring", "t")
⇒ 4
```

Caution: This function does not work for arrays of strings.

rindex (*s*, *t*) Function File

Return the position of the last occurrence of the string *t* in the string *s*, or 0 if no occurrence is found. For example,

```
rindex ("Teststring", "t")
⇒ 6
```

Caution: This function does not work for arrays of strings.

split (*s*, *t*) Function File

Divides the string *s* into pieces separated by *t*, returning the result in a string array (padded with blanks to form a valid matrix). For example,

```
split ("Test string", "t")
⇒ "Tes  "
   " s  "
   "ring"
```

strcmp (*s1*, *s2*) Function File

Compares two strings, returning 1 if they are the same, and 0 otherwise.

Caution: For compatibility with MATLAB, Octave's strcmp function returns 1 if the strings are equal, and 0 otherwise. This is just the opposite of the corresponding C library function.

strrep (*s*, *x*, *y*) Function File

Replaces all occurrences of the substring *x* of the string *s* with the string *y*. For example,

```
strrep ("This is a test string", "is", "%$")
⇒ "Th%$ %$ a test string"
```

substr (*s*, *beg*, *len*) Function File

Return the substring of *s* which starts at character number *beg* and is *len* characters long.

If *OFFSET* is negative, extraction starts that far from the end of the string. If *LEN* is omitted, the substring extends to the end of *S*.

For example,

```
substr ("This is a test string", 6, 9)
⇒ "is a test"
```

This function is patterned after AWK. You can get the same result by *s* (*beg* : (*beg* + *len* - 1)).

5.3 String Conversions

hex2dec (*s*) Function File

Return the decimal number corresponding to the binary number stored in the string *s*. For example,

```
hex2dec ("1110")
⇒ 14
```

If *s* is a string matrix, returns a column vector of converted numbers, one per row of *s*. Invalid rows evaluate to NaN.

dec2bin (*n*, *len*) Function File

Return a binary number corresponding the nonnegative decimal number *n*, as a string of ones and zeros. For example,

```
dec2bin (14)
⇒ "1110"
```

If *n* is a vector, returns a string matrix, one row per value, padded with leading zeros to the width of the largest value.

The optional second argument, *len*, specifies the minimum number of digits in the result.

dec2hex (*n*, *len*) Function File

Return the hexadecimal string corresponding to the nonnegative integer *n*. For example,

```
dec2hex (2748)
⇒ "ABC"
```

If *n* is a vector, returns a string matrix, one row per value, padded with leading zeros to the width of the largest value.

The optional second argument, *len*, specifies the minimum number of digits in the result.

hex2dec (*s*) Function File

Returns the integer corresponding to the hexadecimal number stored in the string *s*. For example,

```
hex2dec ("12B")
⇒ 299
hex2dec ("12b")
⇒ 299
```

If *s* is a string matrix, returns a column vector of converted numbers, one per row of *s*. Invalid rows evaluate to NaN.

dec2base (*n*, *b*, *len*) Function File

Return a string of symbols in base *b* corresponding to the the nonnegative integer *n*.

```
dec2base (123, 3)
⇒ "11120"
```

If n is a vector, return a string matrix with one row per value, padded with leading zeros to the width of the largest value.

If b is a string then the characters of b are used as the symbols for the digits of n . Space (' ') may not be used as a symbol.

```
dec2base (123, "aei")
⇒ "eeeia"
```

The optional third argument, len , specifies the minimum number of digits in the result.

base2dec (s , b) Function File

Convert s from a string of digits of base b into an integer.

```
base2dec ("11120", 3)
⇒ 123
```

If s is a matrix, returns a column vector with one value per row of s . If a row contains invalid symbols then the corresponding value will be NaN. Rows are right-justified before converting so that trailing spaces are ignored.

If b is a string, the characters of b are used as the symbols for the digits of s . Space (' ') may not be used as a symbol.

```
base2dec ("yyyzx", "xyz")
⇒ 123
```

strjust (s , ["left"|"right"|"center"]) Function File

Shift the non-blank text of s to the left, right or center of the string. If s is a string array, justify each string in the array. Null characters are replaced by blanks. If no justification is specified, then all rows are right-justified.

str2num (s) Function File

Convert the string s to a number.

toascii (s) Mapping Function

Return ASCII representation of s in a matrix. For example,

```
toascii ("ASCII")
⇒ [ 65, 83, 67, 73, 73 ]
```

tolower (s) Mapping Function

Return a copy of the string s , with each upper-case character replaced by the corresponding lower-case one; nonalphabetic characters are left unchanged. For example,

```
tolower ("MiXeD cAsE 123")
⇒ "mixed case 123"
```

toupper (*s*) Built-in Function

Return a copy of the string *s*, with each lower-case character replaced by the corresponding upper-case one; nonalphabetic characters are left unchanged. For example,

```
toupper ("MiXeD cAsE 123")
⇒ "MIXED CASE 123"
```

do_string_escapes (*string*) Built-in Function

Convert special characters in *string* to their escaped forms.

undo_string_escapes (*s*) Built-in Function

Converts special characters in strings back to their escaped forms. For example, the expression

```
bell = "\a";
```

assigns the value of the alert character (control-g, ASCII code 7) to the string variable `bell`. If this string is printed, the system will ring the terminal bell (if it is possible). This is normally the desired outcome. However, sometimes it is useful to be able to print the original representation of the string, with the special characters replaced by their escape sequences. For example,

```
octave:13> undo_string_escapes (bell)
ans = \a
```

replaces the unprintable alert character with its printable representation.

warn_num_to_str Built-in Variable

If the value of `warn_num_to_str` is nonzero, a warning is printed for implicit conversions of numbers to their ASCII character equivalents when strings are constructed using a mixture of strings and numbers in matrix notation. For example,

```
[ "f", 111, 111 ]
⇒ "foo"
```

elicits a warning if `warn_num_to_str` is nonzero. The default value is 1.

warn_str_to_num Built-in Variable

If the value of `warn_str_to_num` is nonzero, a warning is printed for implicit conversions of strings to their numeric ASCII equivalents. For example,

```
"abc" + 0
⇒ 97 98 99
```

elicits a warning if `warn_str_to_num` is nonzero. The default value is 0.

warn_single_quote_string Built-in Variable

Print warning if a single quote character is used to introduce a string constant.

5.4 Character Class Functions

Octave also provides the following character class test functions patterned after the functions in the standard C library. They all operate on string arrays and return matrices of zeros and ones. Elements that are nonzero indicate that the condition was true for the corresponding character in the string array. For example,

```
isalpha ("!Q@WERT^Y&")
⇒ [ 0, 1, 0, 1, 1, 1, 1, 0, 1, 0 ]
```

isalnum (*s*) Mapping Function
Return 1 for characters that are letters or digits (**isalpha** (*s*) or **isdigit** (*s*) is true).

isalpha (*s*) Mapping Function
isletter (*s*) Mapping Function
Return true for characters that are letters (**isupper** (*s*) or **islower** (*s*) is true).

isascii (*s*) Mapping Function
Return 1 for characters that are ASCII (in the range 0 to 127 decimal).

isctrl (*s*) Mapping Function
Return 1 for control characters.

isdigit (*s*) Mapping Function
Return 1 for characters that are decimal digits.

isgraph (*s*) Mapping Function
Return 1 for printable characters (but not the space character).

islower (*s*) Mapping Function
Return 1 for characters that are lower case letters.

isprint (*s*) Mapping Function
Return 1 for printable characters (including the space character).

ispunct (*s*) Mapping Function
Return 1 for punctuation characters.

isspace (*s*) Mapping Function
Return 1 for whitespace characters (space, formfeed, newline, carriage return, tab, and vertical tab).

isupper (*s*) Mapping Function
Return 1 for upper case letters.

isxdigit (*s*) Mapping Function
Return 1 for characters that are hexadecimal digits.

6 Data Structures

Octave includes support for organizing data in structures. The current implementation uses an associative array with indices limited to strings, but the syntax is more like C-style structures. Here are some examples of using data structures in Octave.

Elements of structures can be of any value type. For example, the three expressions

```
x.a = 1
x.b = [1, 2; 3, 4]
x.c = "string"
```

create a structure with three elements. To print the value of the structure, you can type its name, just as for any other variable:

```
octave:2> x
x =
{
  a = 1
  b =

      1  2
      3  4

  c = string
}
```

Note that Octave may print the elements in any order.

Structures may be copied.

```
octave:1> y = x
y =
{
  a = 1
  b =

      1  2
      3  4

  c = string
}
```

Since structures are themselves values, structure elements may reference other structures. The following statements change the value of the element **b** of the structure **x** to be a data structure containing the single element **d**, which has a value of 3.

```

octave:1> x.b.d = 3
x.b.d = 3
octave:2> x.b
ans =
{
  d = 3
}
octave:3> x
x =
{
  a = 1
  b =
  {
    d = 3
  }
  c = string
}

```

Note that when Octave prints the value of a structure that contains other structures, only a few levels are displayed. For example,

```

octave:1> a.b.c.d.e = 1;
octave:2> a
a =
{
  b =
  {
    c =
    {
      d: 1x1 struct
    }
  }
}
}

```

This prevents long and confusing output from large deeply nested structures.

struct_levels_to_print

Built-in Variable

You can tell Octave how many structure levels to display by setting the built-in variable `struct_levels_to_print`. The default value is 2.

Functions can return structures. For example, the following function separates the real and complex parts of a matrix and stores them in two elements of the same structure variable.

```

octave:1> function y = f (x)
> y.re = real (x);
> y.im = imag (x);
> endfunction

```

When called with a complex-valued argument, `f` returns the data structure containing the real and imaginary parts of the original function argument.

```

octave:2> f (rand (2) + rand (2) * I);
ans =
{
  im =

      0.26475  0.14828
      0.18436  0.83669

  re =

      0.040239  0.242160
      0.238081  0.402523
}

```

Function return lists can include structure elements, and they may be indexed like any other variable. For example,

```

octave:1> [ x.u, x.s(2:3,2:3), x.v ] = svd ([1, 2; 3, 4])
x.u =

    -0.40455   -0.91451
    -0.91451    0.40455

x.s =

    0.00000  0.00000  0.00000
    0.00000  5.46499  0.00000
    0.00000  0.00000  0.36597

x.v =

    -0.57605    0.81742
    -0.81742   -0.57605

```

It is also possible to cycle through all the elements of a structure in a loop, using a special form of the `for` statement (see Section 12.5 [The `for` Statement], page 84)

The following functions are available to give you information about structures.

isstruct (*expr*) Built-in Function
 Return 1 if the value of the expression *expr* is a structure.

fieldnames (*struct*) Built-in Function
 Return a cell array of strings naming the elements of the structure *struct*. It is an error to call `fieldnames` with an argument that is not a structure.

isfield (*expr*, *name*) Built-in Function
 Return true if the expression *expr* is a structure and it includes an element named *name*. The first argument must be a structure and the second must be a string.

7 Containers

7.1 Lists

list (*a1*, *a2*, ...) Built-in Function
 Create a new list with elements given by the arguments *a1*, *a2*, ...

nth (*list*, *n*) Built-in Function
 Return the *n*-th element of *list*.

append (*list*, *a1*, *a2*, ...) Built-in Function
 Return a new list created by appending *a1*, *a1*, ..., to *list*. If any of the arguments to be appended is a list, its elements are appended individually. For example,

```
x = list (1, 2);
y = list (3, 4);
append (x, y);
```

results in the list containing the four elements '(1 2 3 4)', not a list containing the three elements '(1 2 (3 4))'.

reverse (*list*) Built-in Function
 Return a new list created by reversing the elements of *list*.

splice (*list_1*, *offset*, *length*, *list_2*) Built-in Function
 Replace *length* elements of *list_1* beginning at *offset* with the contents of *list_2* (if any). If *length* is omitted, all elements from *offset* to the end of *list_1* are replaced. As a special case, if *offset* is one greater than the length of *list_1* and *length* is 0, splice is equivalent to **append** (*list_1*, *list_2*).

islist (*x*) Built-in Function
 Return nonzero if *x* is a list.

7.2 Cell Arrays

cell (*x*) Built-in Function

cell (*n*, *m*) Built-in Function
 Create a new cell array object. If invoked with a single scalar argument, **cell** returns a square cell array with the dimension specified. If you supply two scalar arguments, **cell** takes them to be the number of rows and columns. If given a vector with two elements, **cell** uses the values of the elements as the number of rows and columns, respectively.

cellstr (*string*)

Built-in Function

Create a new cell array object from the elements of the string array *string*.

iscell (*x*)

Built-in Function

Return true if *x* is a cell array object. Otherwise, return false.

8 I/O Streams

isstream (*x*)

Built-in Function

Return true if *x* is a stream object. Otherwise, return false.

9 Variables

Variables let you give names to values and refer to them later. You have already seen variables in many of the examples. The name of a variable must be a sequence of letters, digits and underscores, but it may not begin with a digit. Octave does not enforce a limit on the length of variable names, but it is seldom useful to have variables with names longer than about 30 characters. The following are all valid variable names

```
x
x15
__foo_bar_baz__
fucnrthsucngtagdjb
```

However, names like `__foo_bar_baz__` that begin and end with two underscores are understood to be reserved for internal use by Octave. You should not use them in code you write, except to access Octave's documented internal variables and built-in symbolic constants.

Case is significant in variable names. The symbols `a` and `A` are distinct variables.

A variable name is a valid expression by itself. It represents the variable's current value. Variables are given new values with *assignment operators* and *increment operators*. See Section 10.6 [Assignment Expressions], page 72.

A number of variables have special built-in meanings. For example, `ans` holds the current working directory, and `pi` names the ratio of the circumference of a circle to its diameter. See Section 9.4 [Summary of Built-in Variables], page 59, for a list of all the predefined variables. Some of these built-in symbols are constants and may not be changed. Others can be used and assigned just like all other variables, but their values are also used or changed automatically by Octave.

Variables in Octave do not have fixed types, so it is possible to first store a numeric value in a variable and then to later use the same name to hold a string value in the same program. Variables may not be used before they have been given a value. Doing so results in an error.

9.1 Global Variables

A variable that has been declared *global* may be accessed from within a function body without having to pass it as a formal parameter.

A variable may be declared global using a `global` declaration statement. The following statements are all global declarations.

```
global a
global a b
global c = 2
global d = 3 e f = 5
```

A global variable may only be initialized once in a `global` statement. For example, after executing the following code

```
global gvar = 1
global gvar = 2
```

the value of the global variable `gvar` is 1, not 2.

It is necessary declare a variable as global within a function body in order to access it. For example,

```

global x
function f ()
  x = 1;
endfunction
f ()

```

does *not* set the value of the global variable `x` to 1. In order to change the value of the global variable `x`, you must also declare it to be global within the function body, like this

```

function f ()
  global x;
  x = 1;
endfunction

```

Passing a global variable in a function parameter list will make a local copy and not modify the global value. For example, given the function

```

function f (x)
  x = 0
endfunction

```

and the definition of `x` as a global variable at the top level,

```

global x = 13

```

the expression

```

f (x)

```

will display the value of `x` from inside the function as 0, but the value of `x` at the top level remains unchanged, because the function works with a *copy* of its argument.

isglobal (*name*) Built-in Function

Return 1 if *name* is globally visible. Otherwise, return 0. For example,

```

global x
isglobal ("x")
⇒ 1

```

9.2 Persistent Variables

A variable that has been declared *persistent* within a function will retain its contents in memory between subsequent calls to the same function. The difference between persistent variables and global variables is that persistent variables are local in scope to a particular function and are not visible elsewhere.

A variable may be declared persistent using a **persistent** declaration statement. The following statements are all persistent declarations.

```

persistent a
persistent a b
persistent c = 2
persistent d = 3 e f = 5

```

The behavior of persistent variables is equivalent to the behavior of static variables in C. The command **static** in octave is also recognized and is equivalent to **persistent**. Unlike global variables, every initialization statement will re-initialize the variable. For example, after executing the following code

```
persistent pvar = 1
persistent pvar = 2
```

the value of the persistent variable `pvar` is 2.

9.3 Status of Variables

clear [-x] *pattern* . . . Command

Delete the names matching the given patterns from the symbol table. The pattern may contain the following special characters:

- ? Match any single character.
- * Match zero or more characters.
- [*list*] Match the list of characters specified by *list*. If the first character is ! or ^, match all characters except those specified by *list*. For example, the pattern '[a-zA-Z]' will match all lower and upper case alphabetic characters.

For example, the command

```
clear foo b*r
```

clears the name `foo` and all names that begin with the letter `b` and end with the letter `r`.

If `clear` is called without any arguments, all user-defined variables (local and global) are cleared from the symbol table. If `clear` is called with at least one argument, only the visible names matching the arguments are cleared. For example, suppose you have defined a function `foo`, and then hidden it by performing the assignment `foo = 2`. Executing the command `clear foo` once will clear the variable definition and restore the definition of `foo` as a function. Executing `clear foo` a second time will clear the function definition.

With `-x`, clear the variables that don't match the patterns.

This command may not be used within a function body.

who *options pattern* . . . Command

whos *options pattern* . . . Command

List currently defined symbols matching the given patterns. The following are valid options. They may be shortened to one character but may not be combined.

- all List all currently defined symbols.
- builtins List built-in variables and functions. This includes all currently compiled function files, but does not include all function files that are in the `LOADPATH`.
- functions List user-defined functions.

-long Print a long listing including the type and dimensions of any symbols. The symbols in the first column of output indicate whether it is possible to redefine the symbol, and whether it is possible for it to be cleared.

-variables
List user-defined variables.

Valid patterns are the same as described for the `clear` command above. If no patterns are supplied, all symbols from the given category are listed. By default, only user defined functions and variables visible in the local scope are displayed.

The command `whos` is equivalent to `who -long`.

whos *options pattern . . .* Command
See `who`.

whos_line_format Built-in Variable

This string decides in what order attributes of variables are to be printed. The following commands are used:

%b Prints number of bytes occupied by variables.

%e Prints elements held by variables.

%n Prints variable names.

%p Prints protection attributes of variables.

%s Prints dimensions of variables.

%t Prints type names of variables.

Every command may also have a modifier:

l Left alignment.

r Right alignment (this is the default).

c Centered (may only be applied to command `%s`).

A command is composed like this: `%[modifier]<command>[:size_of_parameter[:center-specific[:print_dims[:balance]]]]`;

Command and modifier is already explained. `Size_of_parameter` tells how many columns the parameter will need for printing. `print_dims` tells how many dimensions to print. If number of dimensions exceeds `print_dims`, dimensions will be printed like `x-D`. `center-specific` and `print_dims` may only be applied to command `%s`. A negative value for `print_dims` will cause Octave to print all dimensions whatsoever. `balance` specifies the offset for printing of the dimensions string.

Default format is `" %p:4; %ln:6; %cs:16:6:8:1; %rb:12; %lt:-1;\n"`.

exist (*name*, *type*) Built-in Function

Return 1 if the name exists as a variable, 2 if the name (after appending ‘.m’) is a function file in Octave’s LOADPATH, 3 if the name is a ‘.oct’ file in Octave’s LOADPATH, 5 if the name is a built-in function, 7 if the name is a directory, 101 if the name is a built-in variable, 102 if the name is a built-in constant, or 103 if the name is a function not associated with a file (entered on the command line).

Otherwise, return 0.

This function also returns 2 if a regular file called *name* exists in Octave’s LOADPATH. If you want information about other types of files, you should use some combination of the functions `file_in_path` and `stat` instead.

If the optional argument *type* is supplied, check only for symbols of the specified type. Valid types are

“var” Check only for variables.
 “builtin” Check only for built-in functions.
 “file” Check only for files.
 “dir” Check only for directories.

document (*symbol*, *text*) Built-in Function

Set the documentation string for *symbol* to *text*.

type *options name . . .* Command

Display the definition of each *name* that refers to a function.

Normally also displays if each *name* is user-defined or builtin; the `-q` option suppresses this behaviour.

Currently, Octave can only display functions that can be compiled cleanly, because it uses its internal representation of the function to recreate the program text.

Comments are not displayed because Octave’s parser currently discards them as it converts the text of a function file to its internal representation. This problem may be fixed in a future release.

which *name . . .* Command

Display the type of each *name*. If *name* is defined from a function file, the full name of the file is also displayed.

9.4 Summary of Built-in Variables

Here is a summary of all of Octave’s built-in variables along with cross references to additional information and their default values. In the following table *octave-home* stands for the root directory where all of Octave is installed (the default is ‘`/usr/local`’, *version* stands for the Octave version number (for example, 2.1.x) and *arch* stands for the type of system for which Octave was compiled (for example, `i586-pc-linux-gnu`).

DEFAULT_LOADPATH

See Section 13.6 [Function Files], page 96.

Default value: `".:octave-home/lib/version"`.

EDITOR

See Section 2.4.5 [Commands For History], page 20.

Default value: `"emacs"`.

EXEC_PATH

See Section 34.3 [Controlling Subprocesses], page 307.

Default value: `":$PATH"`.

INFO_FILE

See Section 2.3 [Getting Help], page 16.

Default value: `"octave-home/info/octave.info"`.

INFO_PROGRAM

See Section 2.3 [Getting Help], page 16.

Default value: `"octave-home/libexec/octave/version/exec/arch/info"`.

LOADPATH

See Section 13.6 [Function Files], page 96.

Default value: `":"`, which tells Octave to use the directories specified by the built-in variable `DEFAULT_LOADPATH`.

OCTAVE_HOME

Default value: `"/usr/local"`.

PAGER

See Chapter 16 [Input and Output], page 109.

Default value: `"less"`, or `"more"`.

PS1

See Section 2.4.7 [Customizing the Prompt], page 22.

Default value: `"\s:\#> "`.

PS2

See Section 2.4.7 [Customizing the Prompt], page 22.

Default value: `"> "`.

PS4

See Section 2.4.7 [Customizing the Prompt], page 22.

Default value: `"+ "`.

automatic_replot

See Section 17.1 [Two-Dimensional Plotting], page 133.

Default value: 0.

beep_on_error

See Chapter 14 [Error Handling], page 105.

Default value: 0.

completion_append_char

See Section 2.4.4 [Commands For Completion], page 20.

Default value: `" "`.

default_save_format

See Section 16.1.3 [Simple File I/O], page 114.

Default value: "ascii".

crash_dumps_octave_core

See Section 16.1.3 [Simple File I/O], page 114.

Default value: 1.

fixed_point_format

See Section 4.1 [Matrices], page 33.

Default value: 0.

gnuplot_binary

See Section 17.3 [Three-Dimensional Plotting], page 141.

Default value: "gnuplot".

history_file

See Section 2.4.5 [Commands For History], page 20.

Default value: "~/.octave_hist".

history_size

See Section 2.4.5 [Commands For History], page 20.

Default value: 1024.

ignore_function_time_stamp

See Section 13.6 [Function Files], page 96.

Default value: "system".

max_recursion_depth

See Section 10.2.2 [Recursion], page 68.

Default value: 256.

output_max_field_width

See Section 4.1 [Matrices], page 33.

Default value: 10.

output_precision

See Section 4.1 [Matrices], page 33.

Default value: 5.

page_screen_output

See Chapter 16 [Input and Output], page 109.

Default value: 1.

print_answer_id_name

See Section 16.1.1 [Terminal Output], page 110.

Default value: 1.

print_empty_dimensions

See Section 4.1.1 [Empty Matrices], page 36.

Default value: 1.

return_last_computed_value

See Section 13.5 [Returning From a Function], page 95.

Default value: 0.

save_precision

See Section 16.1.3 [Simple File I/O], page 114.

Default value: 17.

saving_history

See Section 2.4.5 [Commands For History], page 20.

Default value: 1.

sighup_dumps_octave_core

See Section 16.1.3 [Simple File I/O], page 114.

Default value: 1.

sigterm_dumps_octave_core

See Section 16.1.3 [Simple File I/O], page 114.

Default value: 1.

silent_functions

See Section 13.1 [Defining Functions], page 91.

Default value: 0.

split_long_rows

See Section 4.1 [Matrices], page 33.

Default value: 1.

struct_levels_to_print

See Chapter 6 [Data Structures], page 47.

Default value: 2.

suppress_verbose_help_message

See Section 2.3 [Getting Help], page 16.

Default value: 1.

warn_assign_as_truth_value

See Section 12.1 [The if Statement], page 79.

Default value: 1.

warn_comma_in_global_decl

See Section 9.1 [Global Variables], page 55.

Default value: 1.

`warn_divide_by_zero`

See Section 10.3 [Arithmetic Ops], page 68.

Default value: 1.

`warn_empty_list_elements`

See Section 4.1.1 [Empty Matrices], page 36.

Default value: 0.

`warn_fortran_indexing`

See Section 10.1 [Index Expressions], page 65.

Default value: 0.

`warn_function_name_clash`

See Section 13.6 [Function Files], page 96.

Default value: 1.

`warn_imag_to_real`

See Section 18.3 [Special Utility Matrices], page 155.

Default value: 0.

`warn_missing_semicolon`

See Section 13.1 [Defining Functions], page 91.

Default value: 0.

`warn_neg_dim_as_zero`

See Section 18.3 [Special Utility Matrices], page 155.

Default value: 0.

`warn_num_to_str`

See Section 5.3 [String Conversions], page 43.

Default value: 1.

`warn_reload_forces_clear`

See Section 13.8 [Dynamically Linked Functions], page 100.

Default value: 1.

`warn_resize_on_range_error`

See Section 10.1 [Index Expressions], page 65.

Default value: 0.

`warn_separator_insert`

See Section 4.1 [Matrices], page 33.

Default value: 0.

`warn_single_quote_string`

See Section 5.3 [String Conversions], page 43.

Default value: 0.

`warn_str_to_num`

See Section 5.3 [String Conversions], page 43.

Default value: 0.

`warn_undefined_return_values`

See Section 13.2 [Multiple Return Values], page 93.

Default value: 0.

`warn_variable_switch_label`

See Section 12.2 [The switch Statement], page 81.

Default value: 0.

9.5 Defaults from the Environment

Octave uses the values of the following environment variables to set the default values for the corresponding built-in variables. In addition, the values from the environment may be overridden by command-line arguments. See Section 2.1.1 [Command Line Options], page 13.

`EDITOR` See Section 2.4.5 [Commands For History], page 20.

Built-in variable: `EDITOR`.

`OCTAVE_EXEC_PATH`

See Section 34.3 [Controlling Subprocesses], page 307.

Built-in variable: `EXEC_PATH`. Command-line argument: `--exec-path`.

`OCTAVE_PATH`

See Section 13.6 [Function Files], page 96.

Built-in variable: `LOADPATH`. Command-line argument: `--path`.

`OCTAVE_INFO_FILE`

See Section 2.3 [Getting Help], page 16.

Built-in variable: `INFO_FILE`. Command-line argument: `--info-file`.

`OCTAVE_INFO_PROGRAM`

See Section 2.3 [Getting Help], page 16.

Built-in variable: `INFO_PROGRAM`. Command-line argument: `--info-program`.

`OCTAVE_HISTSIZE`

See Section 2.4.5 [Commands For History], page 20.

Built-in variable: `history_size`.

`OCTAVE_HISTFILE`

See Section 2.4.5 [Commands For History], page 20.

Built-in variable: `history_file`.

10 Expressions

Expressions are the basic building block of statements in Octave. An expression evaluates to a value, which you can print, test, store in a variable, pass to a function, or assign a new value to a variable with an assignment operator.

An expression can serve as a statement on its own. Most other kinds of statements contain one or more expressions which specify data to be operated on. As in other languages, expressions in Octave include variables, array references, constants, and function calls, as well as combinations of these with various operators.

10.1 Index Expressions

An *index expression* allows you to reference or extract selected elements of a matrix or vector.

Indices may be scalars, vectors, ranges, or the special operator ‘:’, which may be used to select entire rows or columns.

Vectors are indexed using a single expression. Matrices may be indexed using one or two indices (a warning is issued if a single index is used unless the value of the built-in variable `warn_fortran_indexing` is zero).

warn_fortran_indexing

Built-in Variable

If the value of `warn_fortran_indexing` is nonzero, a warning is printed for expressions which select elements of a two-dimensional matrix using a single index. The default value is 0.

Given the matrix

```
a = [1, 2; 3, 4]
```

all of the following expressions are equivalent

```
a (1, [1, 2])
```

```
a (1, 1:2)
```

```
a (1, :)
```

and select the first row of the matrix.

Indexing a scalar with a vector of ones can be used to create a vector the same size as the index vector, with each element equal to the value of the original scalar. For example, the following statements

```
a = 13;
```

```
a ([1, 1, 1, 1])
```

produce a vector whose four elements are all equal to 13.

Similarly, indexing a scalar with two vectors of ones can be used to create a matrix. For example the following statements

```
a = 13;
```

```
a ([1, 1], [1, 1, 1])
```

create a 2 by 3 matrix with all elements equal to 13.

This is an obscure notation and should be avoided. It is better to use the function `ones` to generate a matrix of the appropriate size whose elements are all one, and then to scale it to produce the desired result. See Section 18.3 [Special Utility Matrices], page 155.

warn_resize_on_range_error

Built-in Variable

If the value of `warn_resize_on_range_error` is nonzero, print a warning when a matrix is resized by an indexed assignment with indices outside the current bounds. The default value is 0.

Note that it is quite inefficient to create a vector using a loop like the one shown in the example above. In this particular case, it would have been much more efficient to use the expression

```
a = sqrt (1:10);
```

thus avoiding the loop entirely. In cases where a loop is still required, or a number of values must be combined to form a larger matrix, it is generally much faster to set the size of the matrix first, and then insert elements using indexing commands. For example, given a matrix `a`,

```
[nr, nc] = size (a);
x = zeros (nr, n * nc);
for i = 1:n
  x(:,(i-1)*nc+1:i*nc) = a;
endfor
```

is considerably faster than

```
x = a;
for i = 1:n-1
  x = [x, a];
endfor
```

particularly for large matrices because Octave does not have to repeatedly resize the result.

10.2 Calling Functions

A *function* is a name for a particular calculation. Because it has a name, you can ask for it by name at any point in the program. For example, the function `sqrt` computes the square root of a number.

A fixed set of functions are *built-in*, which means they are available in every Octave program. The `sqrt` function is one of these. In addition, you can define your own functions. See Chapter 13 [Functions and Scripts], page 91, for information about how to do this.

The way to use a function is with a *function call* expression, which consists of the function name followed by a list of *arguments* in parentheses. The arguments are expressions which give the raw materials for the calculation that the function will do. When there is more than one argument, they are separated by commas. If there are no arguments, you can omit the parentheses, but it is a good idea to include them anyway, to clearly indicate that a function call was intended. Here are some examples:

```
sqrt (x^2 + y^2)    # One argument
ones (n, m)        # Two arguments
rand ()            # No arguments
```

Each function expects a particular number of arguments. For example, the `sqrt` function must be called with a single argument, the number to take the square root of:

```
sqrt (argument)
```

Some of the built-in functions take a variable number of arguments, depending on the particular usage, and their behavior is different depending on the number of arguments supplied.

Like every other expression, the function call has a value, which is computed by the function based on the arguments you give it. In this example, the value of `sqrt (argument)` is the square root of the argument. A function can also have side effects, such as assigning the values of certain variables or doing input or output operations.

Unlike most languages, functions in Octave may return multiple values. For example, the following statement

```
[u, s, v] = svd (a)
```

computes the singular value decomposition of the matrix `a` and assigns the three result matrices to `u`, `s`, and `v`.

The left side of a multiple assignment expression is itself a list of expressions, and is allowed to be a list of variable names or index expressions. See also Section 10.1 [Index Expressions], page 65, and Section 10.6 [Assignment Ops], page 72.

10.2.1 Call by Value

In Octave, unlike Fortran, function arguments are passed by value, which means that each argument in a function call is evaluated and assigned to a temporary location in memory before being passed to the function. There is currently no way to specify that a function parameter should be passed by reference instead of by value. This means that it is impossible to directly alter the value of function parameter in the calling function. It can only change the local copy within the function body. For example, the function

```
function f (x, n)
  while (n-- > 0)
    disp (x);
  endwhile
endfunction
```

displays the value of the first argument `n` times. In this function, the variable `n` is used as a temporary variable without having to worry that its value might also change in the calling function. Call by value is also useful because it is always possible to pass constants for any function parameter without first having to determine that the function will not attempt to modify the parameter.

The caller may use a variable as the expression for the argument, but the called function does not know this: it only knows what value the argument had. For example, given a function called as

```
foo = "bar";
fcn (foo)
```

you should not think of the argument as being “the variable `foo`.” Instead, think of the argument as the string value, `"bar"`.

Even though Octave uses pass-by-value semantics for function arguments, values are not copied unnecessarily. For example,

```
x = rand (1000);
f (x);
```

does not actually force two 1000 by 1000 element matrices to exist *unless* the function `f` modifies the value of its argument. Then Octave must create a copy to avoid changing the value outside the scope of the function `f`, or attempting (and probably failing!) to modify the value of a constant or the value of a temporary result.

10.2.2 Recursion

With some restrictions¹, recursive function calls are allowed. A *recursive function* is one which calls itself, either directly or indirectly. For example, here is an inefficient² way to compute the factorial of a given integer:

```
function retval = fact (n)
  if (n > 0)
    retval = n * fact (n-1);
  else
    retval = 1;
  endif
endfunction
```

This function is recursive because it calls itself directly. It eventually terminates because each time it calls itself, it uses an argument that is one less than was used for the previous call. Once the argument is no longer greater than zero, it does not call itself, and the recursion ends.

The built-in variable `max_recursion_depth` specifies a limit to the recursion depth and prevents Octave from recursing infinitely.

max_recursion_depth

Built-in Variable

Limit the number of times a function may be called recursively. If the limit is exceeded, an error message is printed and control returns to the top level.

The default value is 256.

10.3 Arithmetic Operators

The following arithmetic operators are available, and work on scalars and matrices.

`x + y` Addition. If both operands are matrices, the number of rows and columns must both agree. If one operand is a scalar, its value is added to all the elements of the other operand.

`x .+ y` Element by element addition. This operator is equivalent to `+`.

¹ Some of Octave's function are implemented in terms of functions that cannot be called recursively. For example, the ODE solver `lsode` is ultimately implemented in a Fortran subroutine that cannot be called recursively, so `lsode` should not be called either directly or indirectly from within the user-supplied function that `lsode` requires. Doing so will result in undefined behavior.

² It would be much better to use `prod (1:n)`, or `gamma (n+1)` instead, after first checking to ensure that the value `n` is actually a positive integer.

$x - y$	Subtraction. If both operands are matrices, the number of rows and columns of both must agree.
$x .- y$	Element by element subtraction. This operator is equivalent to $-$.
$x * y$	Matrix multiplication. The number of columns of x must agree with the number of rows of y .
$x .* y$	Element by element multiplication. If both operands are matrices, the number of rows and columns must both agree.
x / y	Right division. This is conceptually equivalent to the expression $(\text{inverse}(y') * x')$ but it is computed without forming the inverse of y' . If the system is not square, or if the coefficient matrix is singular, a minimum norm solution is computed.
$x ./ y$	Element by element right division.
$x \setminus y$	Left division. This is conceptually equivalent to the expression $\text{inverse}(x) * y$ but it is computed without forming the inverse of x . If the system is not square, or if the coefficient matrix is singular, a minimum norm solution is computed.
$x .\setminus y$	Element by element left division. Each element of y is divided by each corresponding element of x .
$x \wedge y$ $x ** y$	Power operator. If x and y are both scalars, this operator returns x raised to the power y . If x is a scalar and y is a square matrix, the result is computed using an eigenvalue expansion. If x is a square matrix. the result is computed by repeated multiplication if y is an integer, and by an eigenvalue expansion if y is not an integer. An error results if both x and y are matrices. The implementation of this operator needs to be improved.
$x \wedge y$	
$x .** y$	Element by element power operator. If both operands are matrices, the number of rows and columns must both agree.
$-x$	Negation.
$+x$	Unary plus. This operator has no effect on the operand.
x'	Complex conjugate transpose. For real arguments, this operator is the same as the transpose operator. For complex arguments, this operator is equivalent to the expression $\text{conj}(x.')$
$x.'$	Transpose.

Note that because Octave's element by element operators begin with a '.', there is a possible ambiguity for statements like

1./m

because the period could be interpreted either as part of the constant or as part of the operator. To resolve this conflict, Octave treats the expression as if you had typed

(1) ./ m

and not

(1.) / m

Although this is inconsistent with the normal behavior of Octave's lexer, which usually prefers to break the input into tokens by preferring the longest possible match at any given point, it is more useful in this case.

warn_divide_by_zero

Built-in Variable

If the value of `warn_divide_by_zero` is nonzero, a warning is issued when Octave encounters a division by zero. If the value is 0, the warning is omitted. The default value is 1.

10.4 Comparison Operators

Comparison operators compare numeric values for relationships such as equality. They are written using *relational operators*.

All of Octave's comparison operators return a value of 1 if the comparison is true, or 0 if it is false. For matrix values, they all work on an element-by-element basis. For example,

```
[1, 2; 3, 4] == [1, 3; 2, 4]
⇒  1  0
   0  1
```

If one operand is a scalar and the other is a matrix, the scalar is compared to each element of the matrix in turn, and the result is the same size as the matrix.

`x < y` True if `x` is less than `y`.

`x <= y` True if `x` is less than or equal to `y`.

`x == y` True if `x` is equal to `y`.

`x >= y` True if `x` is greater than or equal to `y`.

`x > y` True if `x` is greater than `y`.

`x != y`

`x ~= y`

`x <> y` True if `x` is not equal to `y`.

String comparisons may also be performed with the `strcmp` function, not with the comparison operators listed above. See Chapter 5 [Strings], page 39.

10.5 Boolean Expressions

10.5.1 Element-by-element Boolean Operators

An *element-by-element boolean expression* is a combination of comparison expressions using the boolean operators “or” (`|`), “and” (`&`), and “not” (`!`), along with parentheses to control nesting. The truth of the boolean expression is computed by combining the truth values of the corresponding elements of the component expressions. A value is considered to be false if it is zero, and true otherwise.

Element-by-element boolean expressions can be used wherever comparison expressions can be used. They can be used in `if` and `while` statements. However, if a matrix value used as the condition in an `if` or `while` statement is only true if *all* of its elements are nonzero.

Like comparison operations, each element of an element-by-element boolean expression also has a numeric value (1 if true, 0 if false) that comes into play if the result of the boolean expression is stored in a variable, or used in arithmetic.

Here are descriptions of the three element-by-element boolean operators.

boolean1 & *boolean2*

Elements of the result are true if both corresponding elements of *boolean1* and *boolean2* are true.

boolean1 | *boolean2*

Elements of the result are true if either of the corresponding elements of *boolean1* or *boolean2* is true.

! *boolean*

~ *boolean* Each element of the result is true if the corresponding element of *boolean* is false.

For matrix operands, these operators work on an element-by-element basis. For example, the expression

```
[1, 0; 0, 1] & [1, 0; 2, 3]
```

returns a two by two identity matrix.

For the binary operators, the dimensions of the operands must conform if both are matrices. If one of the operands is a scalar and the other a matrix, the operator is applied to the scalar and each element of the matrix.

For the binary element-by-element boolean operators, both subexpressions *boolean1* and *boolean2* are evaluated before computing the result. This can make a difference when the expressions have side effects. For example, in the expression

```
a & b++
```

the value of the variable *b* is incremented even if the variable *a* is zero.

This behavior is necessary for the boolean operators to work as described for matrix-valued operands.

10.5.2 Short-circuit Boolean Operators

Combined with the implicit conversion to scalar values in `if` and `while` conditions, Octave’s element-by-element boolean operators are often sufficient for performing most logical

operations. However, it is sometimes desirable to stop evaluating a boolean expression as soon as the overall truth value can be determined. Octave's *short-circuit* boolean operators work this way.

boolean1 && *boolean2*

The expression *boolean1* is evaluated and converted to a scalar using the equivalent of the operation `all (all (boolean1))`. If it is false, the result of the overall expression is 0. If it is true, the expression *boolean2* is evaluated and converted to a scalar using the equivalent of the operation `all (all (boolean1))`. If it is true, the result of the overall expression is 1. Otherwise, the result of the overall expression is 0.

boolean1 || *boolean2*

The expression *boolean1* is evaluated and converted to a scalar using the equivalent of the operation `all (all (boolean1))`. If it is true, the result of the overall expression is 1. If it is false, the expression *boolean2* is evaluated and converted to a scalar using the equivalent of the operation `all (all (boolean1))`. If it is true, the result of the overall expression is 1. Otherwise, the result of the overall expression is 0.

The fact that both operands may not be evaluated before determining the overall truth value of the expression can be important. For example, in the expression

```
a && b++
```

the value of the variable *b* is only incremented if the variable *a* is nonzero.

This can be used to write somewhat more concise code. For example, it is possible write

```
function f (a, b, c)
  if (nargin > 2 && isstr (c))
    ...
```

instead of having to use two `if` statements to avoid attempting to evaluate an argument that doesn't exist. For example, without the short-circuit feature, it would be necessary to write

```
function f (a, b, c)
  if (nargin > 2)
    if (isstr (c))
      ...
```

Writing

```
function f (a, b, c)
  if (nargin > 2 & isstr (c))
    ...
```

would result in an error if `f` were called with one or two arguments because Octave would be forced to try to evaluate both of the operands for the operator `'&'`.

10.6 Assignment Expressions

An *assignment* is an expression that stores a new value into a variable. For example, the following expression assigns the value 1 to the variable `z`:

```
z = 1
```

After this expression is executed, the variable `z` has the value 1. Whatever old value `z` had before the assignment is forgotten. The '=' sign is called an *assignment operator*.

Assignments can store string values also. For example, the following expression would store the value "this food is good" in the variable `message`:

```
thing = "food"
predicate = "good"
message = [ "this " , thing , " is " , predicate ]
```

(This also illustrates concatenation of strings.)

Most operators (addition, concatenation, and so on) have no effect except to compute a value. If you ignore the value, you might as well not use the operator. An assignment operator is different. It does produce a value, but even if you ignore the value, the assignment still makes itself felt through the alteration of the variable. We call this a *side effect*.

The left-hand operand of an assignment need not be a variable (see Chapter 9 [Variables], page 55). It can also be an element of a matrix (see Section 10.1 [Index Expressions], page 65) or a list of return values (see Section 10.2 [Calling Functions], page 66). These are all called *lvalues*, which means they can appear on the left-hand side of an assignment operator. The right-hand operand may be any expression. It produces the new value which the assignment stores in the specified variable, matrix element, or list of return values.

It is important to note that variables do *not* have permanent types. The type of a variable is simply the type of whatever value it happens to hold at the moment. In the following program fragment, the variable `foo` has a numeric value at first, and a string value later on:

```
octave:13> foo = 1
foo = 1
octave:13> foo = "bar"
foo = bar
```

When the second assignment gives `foo` a string value, the fact that it previously had a numeric value is forgotten.

Assignment of a scalar to an indexed matrix sets all of the elements that are referenced by the indices to the scalar value. For example, if `a` is a matrix with at least two columns,

```
a(:, 2) = 5
```

sets all the elements in the second column of `a` to 5.

Assigning an empty matrix '[]' works in most cases to allow you to delete rows or columns of matrices and vectors. See Section 4.1.1 [Empty Matrices], page 36. For example, given a 4 by 5 matrix `A`, the assignment

```
A (3, :) = []
```

deletes the third row of `A`, and the assignment

```
A (:, 1:2:5) = []
```

deletes the first, second, and fifth columns.

An assignment is an expression, so it has a value. Thus, `z = 1` as an expression has the value 1. One consequence of this is that you can write multiple assignments together:

```
x = y = z = 0
```

stores the value 0 in all three variables. It does this because the value of `z = 0`, which is 0, is stored into `y`, and then the value of `y = z = 0`, which is 0, is stored into `x`.

This is also true of assignments to lists of values, so the following is a valid expression

```
[a, b, c] = [u, s, v] = svd (a)
```

that is exactly equivalent to

```
[u, s, v] = svd (a)
```

```
a = u
```

```
b = s
```

```
c = v
```

In expressions like this, the number of values in each part of the expression need not match. For example, the expression

```
[a, b, c, d] = [u, s, v] = svd (a)
```

is equivalent to the expression above, except that the value of the variable ‘`d`’ is left unchanged, and the expression

```
[a, b] = [u, s, v] = svd (a)
```

is equivalent to

```
[u, s, v] = svd (a)
```

```
a = u
```

```
b = s
```

You can use an assignment anywhere an expression is called for. For example, it is valid to write `x != (y = 1)` to set `y` to 1 and then test whether `x` equals 1. But this style tends to make programs hard to read. Except in a one-shot program, you should rewrite it to get rid of such nesting of assignments. This is never very hard.

print_rhs_assign_val

Built-in Variable

If the value of this variable is non-zero, Octave will print the value of the right hand side of assignment expressions instead of the value of the left hand side (after the assignment).

10.7 Increment Operators

Increment operators increase or decrease the value of a variable by 1. The operator to increment a variable is written as ‘`++`’. It may be used to increment a variable either before or after taking its value.

For example, to pre-increment the variable `x`, you would write `++x`. This would add one to `x` and then return the new value of `x` as the result of the expression. It is exactly the same as the expression `x = x + 1`.

To post-increment a variable `x`, you would write `x++`. This adds one to the variable `x`, but returns the value that `x` had prior to incrementing it. For example, if `x` is equal to 2, the result of the expression `x++` is 2, and the new value of `x` is 3.

For matrix and vector arguments, the increment and decrement operators work on each element of the operand.

Here is a list of all the increment and decrement expressions.

<code>++x</code>	This expression increments the variable <code>x</code> . The value of the expression is the <i>new</i> value of <code>x</code> . It is equivalent to the expression <code>x = x + 1</code> .
<code>--x</code>	This expression decrements the variable <code>x</code> . The value of the expression is the <i>new</i> value of <code>x</code> . It is equivalent to the expression <code>x = x - 1</code> .
<code>x++</code>	This expression causes the variable <code>x</code> to be incremented. The value of the expression is the <i>old</i> value of <code>x</code> .
<code>x--</code>	This expression causes the variable <code>x</code> to be decremented. The value of the expression is the <i>old</i> value of <code>x</code> .

It is not currently possible to increment index expressions. For example, you might expect that the expression `v(4)++` would increment the fourth element of the vector `v`, but instead it results in a parse error. This problem may be fixed in a future release of Octave.

10.8 Operator Precedence

Operator precedence determines how operators are grouped, when different operators appear close by in one expression. For example, `*` has higher precedence than `+`. Thus, the expression `a + b * c` means to multiply `b` and `c`, and then add `a` to the product (i.e., `a + (b * c)`).

You can overrule the precedence of the operators by using parentheses. You can think of the precedence rules as saying where the parentheses are assumed if you do not write parentheses yourself. In fact, it is wise to use parentheses whenever you have an unusual combination of operators, because other people who read the program may not remember what the precedence is in this case. You might forget as well, and then you too could make a mistake. Explicit parentheses will help prevent any such mistake.

When operators of equal precedence are used together, the leftmost operator groups first, except for the assignment and exponentiation operators, which group in the opposite order. Thus, the expression `a - b + c` groups as `(a - b) + c`, but the expression `a = b = c` groups as `a = (b = c)`.

The precedence of prefix unary operators is important when another operator follows the operand. For example, `-x^2` means `-(x^2)`, because `-` has lower precedence than `^`.

Here is a table of the operators in Octave, in order of increasing precedence.

statement separators	<code>;</code> , <code>,</code> , <code>'</code> .
assignment	<code>=</code> . This operator groups right to left.
logical "or" and "and"	<code> </code> , <code>&&</code> .
element-wise "or" and "and"	<code> </code> , <code>&</code> .
relational	<code><</code> , <code><=</code> , <code>==</code> , <code>>=</code> , <code>></code> , <code>!=</code> , <code>~=</code> , <code><></code> .
colon	<code>:</code> .

add, subtract

‘+’, ‘-’.

multiply, divide

‘*’, ‘/’, ‘\’, ‘.\’, ‘.*’, ‘./’.

transpose

‘.’, ‘.’’

unary plus, minus, increment, decrement, and ‘not’

‘+’, ‘-’, ‘++’, ‘--’, ‘!’, ‘~’.

exponentiation

‘^’, ‘**’, ‘.^’, ‘.**’.

11 Evaluation

Normally, you evaluate expressions simply by typing them at the Octave prompt, or by asking Octave to interpret commands that you have saved in a file.

Sometimes, you may find it necessary to evaluate an expression that has been computed and stored in a string, or use a string as the name of a function to call. The `eval` and `feval` functions allow you to do just that, and are necessary in order to evaluate commands that are not known until run time, or to write functions that will need to call user-supplied functions.

eval (*try*, *catch*) Built-in Function
Parse the string *try* and evaluate it as if it were an Octave program. If that fails, evaluate the string *catch*. The string *try* is evaluated in the current context, so any results remain available after `eval` returns.

feval (*name*, ...) Built-in Function
Evaluate the function named *name*. Any arguments after the first are passed on to the named function. For example,

```
feval ("acos", -1)
⇒ 3.1416
```

calls the function `acos` with the argument `'-1'`.

The function `feval` is necessary in order to be able to write functions that call user-supplied functions, because Octave does not have a way to declare a pointer to a function (like C) or to declare a special kind of variable that can be used to hold the name of a function (like `EXTERNAL` in Fortran). Instead, you must refer to functions by name, and use `feval` to call them.

Here is a simple-minded function using `feval` that finds the root of a user-supplied function of one variable using Newton's method.

```
function result = newtroot (fname, x)

# usage: newtroot (fname, x)
#
#  fname : a string naming a function f(x).
#  x      : initial guess

delta = tol = sqrt (eps);
maxit = 200;
fx = feval (fname, x);
for i = 1:maxit
  if (abs (fx) < tol)
    result = x;
    return;
  else
    fx_new = feval (fname, x + delta);
    deriv = (fx_new - fx) / delta;
    x = x - fx / deriv;
    fx = fx_new;
  endif
endfor

result = x;

endfunction
```

Note that this is only meant to be an example of calling user-supplied functions and should not be taken too seriously. In addition to using a more robust algorithm, any serious code would check the number and type of all the arguments, ensure that the supplied function really was a function, etc. See Section 4.4 [Predicates for Numeric Objects], page 38, for example, for a list of predicates for numeric objects, and See Section 9.3 [Status of Variables], page 57, for a description of the `exist` function.

12 Statements

Statements may be a simple constant expression or a complicated list of nested loops and conditional statements.

Control statements such as `if`, `while`, and so on control the flow of execution in Octave programs. All the control statements start with special keywords such as `if` and `while`, to distinguish them from simple expressions. Many control statements contain other statements; for example, the `if` statement contains another statement which may or may not be executed.

Each control statement has a corresponding *end* statement that marks the end of the end of the control statement. For example, the keyword `endif` marks the end of an `if` statement, and `endwhile` marks the end of a `while` statement. You can use the keyword `end` anywhere a more specific end keyword is expected, but using the more specific keywords is preferred because if you use them, Octave is able to provide better diagnostics for mismatched or missing end tokens.

The list of statements contained between keywords like `if` or `while` and the corresponding end statement is called the *body* of a control statement.

12.1 The `if` Statement

The `if` statement is Octave's decision-making statement. There are three basic forms of an `if` statement. In its simplest form, it looks like this:

```
if (condition)
  then-body
endif
```

condition is an expression that controls what the rest of the statement will do. The *then-body* is executed only if *condition* is true.

The condition in an `if` statement is considered true if its value is non-zero, and false if its value is zero. If the value of the conditional expression in an `if` statement is a vector or a matrix, it is considered true only if *all* of the elements are non-zero.

The second form of an `if` statement looks like this:

```
if (condition)
  then-body
else
  else-body
endif
```

If *condition* is true, *then-body* is executed; otherwise, *else-body* is executed.

Here is an example:

```
if (rem (x, 2) == 0)
  printf ("x is even\n");
else
  printf ("x is odd\n");
endif
```

In this example, if the expression `rem (x, 2) == 0` is true (that is, the value of `x` is divisible by 2), then the first `printf` statement is evaluated, otherwise the second `printf` statement is evaluated.

The third and most general form of the `if` statement allows multiple decisions to be combined in a single statement. It looks like this:

```
if (condition)
  then-body
elseif (condition)
  elseif-body
else
  else-body
endif
```

Any number of `elseif` clauses may appear. Each condition is tested in turn, and if one is found to be true, its corresponding *body* is executed. If none of the conditions are true and the `else` clause is present, its body is executed. Only one `else` clause may appear, and it must be the last part of the statement.

In the following example, if the first condition is true (that is, the value of `x` is divisible by 2), then the first `printf` statement is executed. If it is false, then the second condition is tested, and if it is true (that is, the value of `x` is divisible by 3), then the second `printf` statement is executed. Otherwise, the third `printf` statement is performed.

```
if (rem (x, 2) == 0)
  printf ("x is even\n");
elseif (rem (x, 3) == 0)
  printf ("x is odd and divisible by 3\n");
else
  printf ("x is odd\n");
endif
```

Note that the `elseif` keyword must not be spelled `else if`, as is allowed in Fortran. If it is, the space between the `else` and `if` will tell Octave to treat this as a new `if` statement within another `if` statement's `else` clause. For example, if you write

```
if (c1)
  body-1
else if (c2)
  body-2
endif
```

Octave will expect additional input to complete the first `if` statement. If you are using Octave interactively, it will continue to prompt you for additional input. If Octave is reading this input from a file, it may complain about missing or mismatched `end` statements, or, if you have not used the more specific `end` statements (`endif`, `endfor`, etc.), it may simply produce incorrect results, without producing any warning messages.

It is much easier to see the error if we rewrite the statements above like this,

```
if (c1)
  body-1
else
  if (c2)
    body-2
  endif
endif
```

using the indentation to show how Octave groups the statements. See Chapter 13 [Functions and Scripts], page 91.

warn_assign_as_truth_value

Built-in Variable

If the value of `warn_assign_as_truth_value` is nonzero, a warning is issued for statements like

```
if (s = t)
  ...
```

since such statements are not common, and it is likely that the intent was to write

```
if (s == t)
  ...
```

instead.

There are times when it is useful to write code that contains assignments within the condition of a `while` or `if` statement. For example, statements like

```
while (c = getc())
  ...
```

are common in C programming.

It is possible to avoid all warnings about such statements by setting `warn_assign_as_truth_value` to 0, but that may also let real errors like

```
if (x = 1) # intended to test (x == 1)!
  ...
```

slip by.

In such cases, it is possible suppress errors for specific statements by writing them with an extra set of parentheses. For example, writing the previous example as

```
while ((c = getc()))
  ...
```

will prevent the warning from being printed for this statement, while allowing Octave to warn about other assignments used in conditional contexts.

The default value of `warn_assign_as_truth_value` is 1.

12.2 The switch Statement

The `switch` statement was introduced in Octave 2.0.5. It should be considered experimental, and details of the implementation may change slightly in future versions of Octave. If you have comments or would like to share your experiences in trying to use this new command in real programs, please send them to octave-maintainers@bevo.che.wisc.edu. (But if you think you've found a bug, please report it to bug-octave@bevo.che.wisc.edu.)

The general form of the `switch` statement is

```
switch expression
  case label
    command_list
  case label
    command_list
  ...

  otherwise
    command_list
endswitch
```

- The identifiers `switch`, `case`, `otherwise`, and `endswitch` are now keywords.
- The *label* may be any expression.
- Duplicate *label* values are not detected. The *command_list* corresponding to the first match will be executed.
- You must have at least one *case label command_list* clause.
- The `otherwise` *command_list* clause is optional.
- As with all other specific `end` keywords, `endswitch` may be replaced by `end`, but you can get better diagnostics if you use the specific forms.
- Cases are exclusive, so they don't 'fall through' as do the cases in the `switch` statement of the C language.
- The *command_list* elements are not optional. Making the list optional would have meant requiring a separator between the label and the command list. Otherwise, things like

```
switch (foo)
  case (1) -2
  ...
```

would produce surprising results, as would

```
switch (foo)
  case (1)
  case (2)
    doit ();
  ...
```

particularly for C programmers.

- The implementation is simple-minded and currently offers no real performance improvement over an equivalent `if` block, even if all the labels are integer constants. Perhaps a future variation on this could detect all constant integer labels and improve performance by using a jump table.

warn_variable_switch_label

Built-in Variable

If the value of this variable is nonzero, Octave will print a warning if a `switch` label is not a constant or constant expression

12.3 The while Statement

In programming, a *loop* means a part of a program that is (or at least can be) executed two or more times in succession.

The `while` statement is the simplest looping statement in Octave. It repeatedly executes a statement as long as a condition is true. As with the condition in an `if` statement, the condition in a `while` statement is considered true if its value is non-zero, and false if its value is zero. If the value of the conditional expression in a `while` statement is a vector or a matrix, it is considered true only if *all* of the elements are non-zero.

Octave's `while` statement looks like this:

```

while (condition)
  body
endwhile

```

Here *body* is a statement or list of statements that we call the *body* of the loop, and *condition* is an expression that controls how long the loop keeps running.

The first thing the **while** statement does is test *condition*. If *condition* is true, it executes the statement *body*. After *body* has been executed, *condition* is tested again, and if it is still true, *body* is executed again. This process repeats until *condition* is no longer true. If *condition* is initially false, the body of the loop is never executed.

This example creates a variable `fib` that contains the first ten elements of the Fibonacci sequence.

```

fib = ones (1, 10);
i = 3;
while (i <= 10)
  fib (i) = fib (i-1) + fib (i-2);
  i++;
endwhile

```

Here the body of the loop contains two statements.

The loop works like this: first, the value of `i` is set to 3. Then, the **while** tests whether `i` is less than or equal to 10. This is the case when `i` equals 3, so the value of the `i`-th element of `fib` is set to the sum of the previous two values in the sequence. Then the `i++` increments the value of `i` and the loop repeats. The loop terminates when `i` reaches 11.

A newline is not required between the condition and the body; but using one makes the program clearer unless the body is very simple.

See Section 12.1 [The if Statement], page 79, for a description of the variable `warn_assign_as_truth_value`.

12.4 The do-until Statement

The **do-until** statement is similar to the **while** statement, except that it repeatedly executes a statement until a condition becomes true, and the test of the condition is at the end of the loop, so the body of the loop is always executed at least once. As with the condition in an **if** statement, the condition in a **do-until** statement is considered true if its value is non-zero, and false if its value is zero. If the value of the conditional expression in a **do-until** statement is a vector or a matrix, it is considered true only if *all* of the elements are non-zero.

Octave's **do-until** statement looks like this:

```

do
  body
until (condition)

```

Here *body* is a statement or list of statements that we call the *body* of the loop, and *condition* is an expression that controls how long the loop keeps running.

This example creates a variable `fib` that contains the first ten elements of the Fibonacci sequence.

```

fib = ones (1, 10);
i = 2;
do
    i++;
    fib (i) = fib (i-1) + fib (i-2);
until (i == 10)

```

A newline is not required between the `do` keyword and the body; but using one makes the program clearer unless the body is very simple.

See Section 12.1 [The `if` Statement], page 79, for a description of the variable `warn_assign_as_truth_value`.

12.5 The `for` Statement

The `for` statement makes it more convenient to count iterations of a loop. The general form of the `for` statement looks like this:

```

for var = expression
    body
endfor

```

where *body* stands for any statement or list of statements, *expression* is any valid expression, and *var* may take several forms. Usually it is a simple variable name or an indexed variable. If the value of *expression* is a structure, *var* may also be a list. See Section 12.5.1 [Looping Over Structure Elements], page 84, below.

The assignment expression in the `for` statement works a bit differently than Octave's normal assignment statement. Instead of assigning the complete result of the expression, it assigns each column of the expression to *var* in turn. If *expression* is a range, a row vector, or a scalar, the value of *var* will be a scalar each time the loop body is executed. If *var* is a column vector or a matrix, *var* will be a column vector each time the loop body is executed.

The following example shows another way to create a vector containing the first ten elements of the Fibonacci sequence, this time using the `for` statement:

```

fib = ones (1, 10);
for i = 3:10
    fib (i) = fib (i-1) + fib (i-2);
endfor

```

This code works by first evaluating the expression `3:10`, to produce a range of values from 3 to 10 inclusive. Then the variable `i` is assigned the first element of the range and the body of the loop is executed once. When the end of the loop body is reached, the next value in the range is assigned to the variable `i`, and the loop body is executed again. This process continues until there are no more elements to assign.

Although it is possible to rewrite all `for` loops as `while` loops, the Octave language has both statements because often a `for` loop is both less work to type and more natural to think of. Counting the number of iterations is very common in loops and it can be easier to think of this counting as part of looping rather than as something to do inside the loop.

12.5.1 Looping Over Structure Elements

A special form of the `for` statement allows you to loop over all the elements of a structure:

```
for [ val, key ] = expression
  body
endfor
```

In this form of the `for` statement, the value of *expression* must be a structure. If it is, *key* and *val* are set to the name of the element and the corresponding value in turn, until there are no more elements. For example,

```
x.a = 1
x.b = [1, 2; 3, 4]
x.c = "string"
for [val, key] = x
  key
  val
endfor

+ key = a
+ val = 1
+ key = b
+ val =
+
+   1  2
+   3  4
+
+ key = c
+ val = string
```

The elements are not accessed in any particular order. If you need to cycle through the list in a particular way, you will have to use the function `struct_elements` and sort the list yourself.

The *key* variable may also be omitted. If it is, the brackets are also optional. This is useful for cycling through the values of all the structure elements when the names of the elements do not need to be known.

12.6 The `break` Statement

The `break` statement jumps out of the innermost `for` or `while` loop that encloses it. The `break` statement may only be used within the body of a loop. The following example finds the smallest divisor of a given integer, and also identifies prime numbers:

```
num = 103;
div = 2;
while (div*div <= num)
  if (rem (num, div) == 0)
    break;
  endif
  div++;
endwhile
if (rem (num, div) == 0)
  printf ("Smallest divisor of %d is %d\n", num, div)
else
  printf ("%d is prime\n", num);
endif
```

When the remainder is zero in the first `while` statement, Octave immediately *breaks out* of the loop. This means that Octave proceeds immediately to the statement following the loop and continues processing. (This is very different from the `exit` statement which stops the entire Octave program.)

Here is another program equivalent to the previous one. It illustrates how the *condition* of a `while` statement could just as well be replaced with a `break` inside an `if`:

```
num = 103;
div = 2;
while (1)
  if (rem (num, div) == 0)
    printf ("Smallest divisor of %d is %d\n", num, div);
    break;
  endif
  div++;
  if (div*div > num)
    printf ("%d is prime\n", num);
    break;
  endif
endwhile
```

12.7 The continue Statement

The `continue` statement, like `break`, is used only inside `for` or `while` loops. It skips over the rest of the loop body, causing the next cycle around the loop to begin immediately. Contrast this with `break`, which jumps out of the loop altogether. Here is an example:

```

# print elements of a vector of random
# integers that are even.

# first, create a row vector of 10 random
# integers with values between 0 and 100:

vec = round (rand (1, 10) * 100);

# print what we're interested in:

for x = vec
  if (rem (x, 2) != 0)
    continue;
  endif
  printf ("%d\n", x);
endfor

```

If one of the elements of `vec` is an odd number, this example skips the print statement for that element, and continues back to the first statement in the loop.

This is not a practical example of the `continue` statement, but it should give you a clear understanding of how it works. Normally, one would probably write the loop like this:

```

for x = vec
  if (rem (x, 2) == 0)
    printf ("%d\n", x);
  endif
endfor

```

12.8 The `unwind_protect` Statement

Octave supports a limited form of exception handling modelled after the `unwind-protect` form of Lisp.

The general form of an `unwind_protect` block looks like this:

```

unwind_protect
  body
unwind_protect_cleanup
  cleanup
end_unwind_protect

```

Where *body* and *cleanup* are both optional and may contain any Octave expressions or commands. The statements in *cleanup* are guaranteed to be executed regardless of how control exits *body*.

This is useful to protect temporary changes to global variables from possible errors. For example, the following code will always restore the original value of the built-in variable `warn_fortran_indexing` even if an error occurs while performing the indexing operation.

```

save_warn_fortran_indexing = warn_fortran_indexing;
unwind_protect
  warn_fortran_indexing = 1;
  elt = a (idx)
unwind_protect_cleanup
  warn_fortran_indexing = save_warn_fortran_indexing;
end_unwind_protect

```

Without `unwind_protect`, the value of `warn_fortran_indexing` would not be restored if an error occurs while performing the indexing operation because evaluation would stop at the point of the error and the statement to restore the value would not be executed.

12.9 The try Statement

In addition to `unwind_protect`, Octave supports another limited form of exception handling.

The general form of a `try` block looks like this:

```

try
  body
catch
  cleanup
end_try_catch

```

Where *body* and *cleanup* are both optional and may contain any Octave expressions or commands. The statements in *cleanup* are only executed if an error occurs in *body*.

No warnings or error messages are printed while *body* is executing. If an error does occur during the execution of *body*, *cleanup* can use the function `lasterr` to access the text of the message that would have been printed. This is the same as `eval (try, catch)` but it is more efficient since the commands do not need to be parsed each time the *try* and *catch* statements are evaluated. See Chapter 14 [Error Handling], page 105, for more information about the `lasterr` function.

Octave's *try* block is a very limited variation on the Lisp condition-case form (limited because it cannot handle different classes of errors separately). Perhaps at some point Octave can have some sort of classification of errors and try-catch can be improved to be as powerful as condition-case in Lisp.

12.10 Continuation Lines

In the Octave language, most statements end with a newline character and you must tell Octave to ignore the newline character in order to continue a statement from one line to the next. Lines that end with the characters `...` or `\` are joined with the following line before they are divided into tokens by Octave's parser. For example, the lines

```

x = long_variable_name ...
  + longer_variable_name \
  - 42

```

form a single statement. The backslash character on the second line above is interpreted a continuation character, *not* as a division operator.

For continuation lines that do not occur inside string constants, whitespace and comments may appear between the continuation marker and the newline character. For example, the statement

```
x = long_variable_name ...      # comment one
  + longer_variable_name \     # comment two
  - 42                          # last comment
```

is equivalent to the one shown above. Inside string constants, the continuation marker must appear at the end of the line just before the newline character.

Input that occurs inside parentheses can be continued to the next line without having to use a continuation marker. For example, it is possible to write statements like

```
if (fine_dining_destination == on_a_boat
    || fine_dining_destination == on_a_train)
    seuss (i, will, not, eat, them, sam, i, am, i,
          will, not, eat, green, eggs, and, ham);
endif
```

without having to add to the clutter with continuation markers.

13 Functions and Script Files

Complicated Octave programs can often be simplified by defining functions. Functions can be defined directly on the command line during interactive Octave sessions, or in external files, and can be called just like built-in functions.

13.1 Defining Functions

In its simplest form, the definition of a function named *name* looks like this:

```
function name
  body
endfunction
```

A valid function name is like a valid variable name: a sequence of letters, digits and underscores, not starting with a digit. Functions share the same pool of names as variables.

The function *body* consists of Octave statements. It is the most important part of the definition, because it says what the function should actually *do*.

For example, here is a function that, when executed, will ring the bell on your terminal (assuming that it is possible to do so):

```
function wakeup
  printf ("\a");
endfunction
```

The `printf` statement (see Chapter 16 [Input and Output], page 109) simply tells Octave to print the string `"\a"`. The special character ‘`\a`’ stands for the alert character (ASCII 7). See Chapter 5 [Strings], page 39.

Once this function is defined, you can ask Octave to evaluate it by typing the name of the function.

Normally, you will want to pass some information to the functions you define. The syntax for passing parameters to a function in Octave is

```
function name (arg-list)
  body
endfunction
```

where *arg-list* is a comma-separated list of the function’s arguments. When the function is called, the argument names are used to hold the argument values given in the call. The list of arguments may be empty, in which case this form is equivalent to the one shown above.

To print a message along with ringing the bell, you might modify the `beep` to look like this:

```
function wakeup (message)
  printf ("\a%s\n", message);
endfunction
```

Calling this function using a statement like this

```
wakeup ("Rise and shine!");
```

will cause Octave to ring your terminal’s bell and print the message ‘`Rise and shine!`’, followed by a newline character (the ‘`\n`’ in the first argument to the `printf` statement).

In most cases, you will also want to get some information back from the functions you define. Here is the syntax for writing a function that returns a single value:

```
function ret-var = name (arg-list)
  body
endfunction
```

The symbol *ret-var* is the name of the variable that will hold the value to be returned by the function. This variable must be defined before the end of the function body in order for the function to return a value.

Variables used in the body of a function are local to the function. Variables named in *arg-list* and *ret-var* are also local to the function. See Section 9.1 [Global Variables], page 55, for information about how to access global variables inside a function.

For example, here is a function that computes the average of the elements of a vector:

```
function retval = avg (v)
  retval = sum (v) / length (v);
endfunction
```

If we had written `avg` like this instead,

```
function retval = avg (v)
  if (isvector (v))
    retval = sum (v) / length (v);
  endif
endfunction
```

and then called the function with a matrix instead of a vector as the argument, Octave would have printed an error message like this:

```
error: 'retval' undefined near line 1 column 10
error: evaluating index expression near line 7, column 1
```

because the body of the `if` statement was never executed, and `retval` was never defined. To prevent obscure errors like this, it is a good idea to always make sure that the return variables will always have values, and to produce meaningful error messages when problems are encountered. For example, `avg` could have been written like this:

```
function retval = avg (v)
  retval = 0;
  if (isvector (v))
    retval = sum (v) / length (v);
  else
    error ("avg: expecting vector argument");
  endif
endfunction
```

There is still one additional problem with this function. What if it is called without an argument? Without additional error checking, Octave will probably print an error message that won't really help you track down the source of the error. To allow you to catch errors like this, Octave provides each function with an automatic variable called `nargin`. Each time a function is called, `nargin` is automatically initialized to the number of arguments that have actually been passed to the function. For example, we might rewrite the `avg` function like this:

```

function retval = avg (v)
    retval = 0;
    if (nargin != 1)
        usage ("avg (vector)");
    endif
    if (isvector (v))
        retval = sum (v) / length (v);
    else
        error ("avg: expecting vector argument");
    endif
endfunction

```

Although Octave does not automatically report an error if you call a function with more arguments than expected, doing so probably indicates that something is wrong. Octave also does not automatically report an error if a function is called with too few arguments, but any attempt to use a variable that has not been given a value will result in an error. To avoid such problems and to provide useful messages, we check for both possibilities and issue our own error message.

nargin () Built-in Function
nargin (*fcn_name*) Built-in Function

Within a function, return the number of arguments passed to the function. At the top level, return the number of command line arguments passed to Octave. If called with the optional argument *fcn_name*, return the maximum number of arguments the named function can accept, or -1 if the function accepts a variable number of arguments.

silent_functions Built-in Variable

If the value of **silent_functions** is nonzero, internal output from a function is suppressed. Otherwise, the results of expressions within a function body that are not terminated with a semicolon will have their values printed. The default value is 0.

For example, if the function

```

function f ()
    2 + 2
endfunction

```

is executed, Octave will either print `'ans = 4'` or nothing depending on the value of **silent_functions**.

warn_missing_semicolon Built-in Variable

If the value of this variable is nonzero, Octave will warn when statements in function definitions don't end in semicolons. The default value is 0.

13.2 Multiple Return Values

Unlike many other computer languages, Octave allows you to define functions that return more than one value. The syntax for defining functions that return multiple values is

```
function [ret-list] = name (arg-list)
  body
endfunction
```

where *name*, *arg-list*, and *body* have the same meaning as before, and *ret-list* is a comma-separated list of variable names that will hold the values returned from the function. The list of return values must have at least one element. If *ret-list* has only one element, this form of the `function` statement is equivalent to the form described in the previous section.

Here is an example of a function that returns two values, the maximum element of a vector and the index of its first occurrence in the vector.

```
function [max, idx] = vmax (v)
  idx = 1;
  max = v (idx);
  for i = 2:length (v)
    if (v (i) > max)
      max = v (i);
      idx = i;
    endif
  endfor
endfunction
```

In this particular case, the two values could have been returned as elements of a single array, but that is not always possible or convenient. The values to be returned may not have compatible dimensions, and it is often desirable to give the individual return values distinct names.

In addition to setting `nargin` each time a function is called, Octave also automatically initializes `nargout` to the number of values that are expected to be returned. This allows you to write functions that behave differently depending on the number of values that the user of the function has requested. The implicit assignment to the built-in variable `ans` does not figure in the count of output arguments, so the value of `nargout` may be zero.

The `svd` and `lu` functions are examples of built-in functions that behave differently depending on the value of `nargout`.

It is possible to write functions that only set some return values. For example, calling the function

```
function [x, y, z] = f ()
  x = 1;
  z = 2;
endfunction
```

as

```
[a, b, c] = f ()
```

produces:

```
a = 1
```

```
b = [] (0x0)
```

```
c = 2
```

along with a warning if the value of the built-in variable `warn_undefined_return_values` is nonzero.

nargout () Built-in Function

nargout (*fcn_name*) Built-in Function

Within a function, return the number of values the caller expects to receive. If called with the optional argument *fcn_name*, return the maximum number of values the named function can produce, or -1 if the function can produce a variable number of values.

For example,

```
f ()
```

will cause **nargout** to return 0 inside the function **f** and

```
[s, t] = f ()
```

will cause **nargout** to return 2 inside the function **f**.

At the top level, **nargout** is undefined.

warn_undefined_return_values Built-in Variable

If the value of **warn_undefined_return_values** is nonzero, print a warning if a function does not define all the values in the return list which are expected. The default value is 1.

narginchk (*nargin_min*, *nargin_max*, *n*) Function File

If *n* is in the range *nargin_min* through *nargin_max* inclusive, return the empty matrix. Otherwise, return a message indicating whether *n* is too large or too small.

This is useful for checking to see that the number of arguments supplied to a function is within an acceptable range.

13.3 Variable-length Argument Lists

13.4 Variable-length Return Lists

13.5 Returning From a Function

The body of a user-defined function can contain a **return** statement. This statement returns control to the rest of the Octave program. It looks like this:

```
return
```

Unlike the **return** statement in C, Octave's **return** statement cannot be used to return a value from a function. Instead, you must assign values to the list of return variables that are part of the **function** statement. The **return** statement simply makes it easier to exit a function from a deeply nested loop or conditional statement.

Here is an example of a function that checks to see if any elements of a vector are nonzero.

```
function retval = any_nonzero (v)
  retval = 0;
  for i = 1:length (v)
    if (v (i) != 0)
      retval = 1;
      return;
    endif
  endfor
  printf ("no nonzero elements found\n");
endfunction
```

Note that this function could not have been written using the `break` statement to exit the loop once a nonzero value is found without adding extra logic to avoid printing the message if the vector does contain a nonzero element.

return

Keyword

When Octave encounters the keyword `return` inside a function or script, it returns control to the caller immediately. At the top level, the return statement is ignored. A `return` statement is assumed at the end of every function definition.

13.6 Function Files

Except for simple one-shot programs, it is not practical to have to define all the functions you need each time you need them. Instead, you will normally want to save them in a file so that you can easily edit them, and save them for use at a later time.

Octave does not require you to load function definitions from files before using them. You simply need to put the function definitions in a place where Octave can find them.

When Octave encounters an identifier that is undefined, it first looks for variables or functions that are already compiled and currently listed in its symbol table. If it fails to find a definition there, it searches the list of directories specified by the built-in variable `LOADPATH` for files ending in `‘.m’` that have the same base name as the undefined identifier.¹ Once Octave finds a file with a name that matches, the contents of the file are read. If it defines a *single* function, it is compiled and executed. See Section 13.7 [Script Files], page 98, for more information about how you can define more than one function in a single file.

When Octave defines a function from a function file, it saves the full name of the file it read and the time stamp on the file. After that, it checks the time stamp on the file every time it needs the function. If the time stamp indicates that the file has changed since the last time it was read, Octave reads it again.

Checking the time stamp allows you to edit the definition of a function while Octave is running, and automatically use the new function definition without having to restart your Octave session. Checking the time stamp every time a function is used is rather inefficient, but it has to be done to ensure that the correct function definition is used.

To avoid degrading performance unnecessarily by checking the time stamps on functions that are not likely to change, Octave assumes that function files in the directory tree `‘octave-home/share/octave/version/m’` will not change, so it doesn’t have to check their time

¹ The `‘.m’` suffix was chosen for compatibility with MATLAB.

stamps every time the functions defined in those files are used. This is normally a very good assumption and provides a significant improvement in performance for the function files that are distributed with Octave.

If you know that your own function files will not change while you are running Octave, you can improve performance by setting the variable `ignore_function_time_stamp` to `"all"`, so that Octave will ignore the time stamps for all function files. Setting it to `"system"` gives the default behavior. If you set it to anything else, Octave will check the time stamps on all function files.

DEFAULT_LOADPATH

Built-in Variable

A colon separated list of directories in which to search for function files. The value of this variable is automatically substituted for leading, trailing, or doubled colons that appear in the built-in variable `LOADPATH`.

LOADPATH

Built-in Variable

A colon separated list of directories in which to search for function files. See Chapter 13 [Functions and Scripts], page 91. The value of `LOADPATH` overrides the environment variable `OCTAVE_PATH`. See Appendix C [Installation], page 329.

`LOADPATH` is now handled in the same way as `TeX` handles `TEXINPUTS`. Leading, trailing, or doubled colons that appear in `LOADPATH` are replaced by the value of `DEFAULT_LOADPATH`. The default value of `LOADPATH` is `":"`, which tells Octave to search in the directories specified by `DEFAULT_LOADPATH`.

In addition, if any path element ends in `'/'`, that directory and all subdirectories it contains are searched recursively for function files. This can result in a slight delay as Octave caches the lists of files found in the `LOADPATH` the first time Octave searches for a function. After that, searching is usually much faster because Octave normally only needs to search its internal cache for files.

To improve performance of recursive directory searching, it is best for each directory that is to be searched recursively to contain *either* additional subdirectories *or* function files, but not a mixture of both.

See Section 13.10 [Organization of Functions], page 104, for a description of the function file directories that are distributed with Octave.

rehash ()

Built-in Function

Reinitialize Octave's `LOADPATH` directory cache.

file_in_loadpath (file)

Built-in Function

file_in_loadpath (file, "all")

Built-in Function

Return the absolute name name of *file* if it can be found in the list of directories specified by `LOADPATH`. If no file is found, return an empty matrix.

If the first argument is a cell array of of strings, search each directory of the loadpath for element of the cell array and return the first that matches.

If the second optional argument `"all"` is supplied, return a cell array containing the list of all files that have the same name in the path. If no files are found, return an empty cell array.

ignore_function_time_stamp Built-in Variable

This variable can be used to prevent Octave from making the system call `stat` each time it looks up functions defined in function files. If `ignore_function_time_stamp` to `"system"`, Octave will not automatically recompile function files in subdirectories of `'octave-home/lib/version'` if they have changed since they were last compiled, but will recompile other function files in the `LOADPATH` if they change. If set to `"all"`, Octave will not recompile any function files unless their definitions are removed with `clear`. For any other value of `ignore_function_time_stamp`, Octave will always check to see if functions defined in function files need to be recompiled. The default value of `ignore_function_time_stamp` is `"system"`.

warn_function_name_clash Built-in Variable

If the value of `warn_function_name_clash` is nonzero, a warning is issued when Octave finds that the name of a function defined in a function file differs from the name of the file. (If the names disagree, the name declared inside the file is ignored.) If the value is 0, the warning is omitted. The default value is 1.

warn_future_time_stamp Built-in Variable

If the value of this variable is nonzero, Octave will print a warning if it finds a function file with a time stamp that is in the future.

13.7 Script Files

A script file is a file containing (almost) any sequence of Octave commands. It is read and evaluated just as if you had typed each command at the Octave prompt, and provides a convenient way to perform a sequence of commands that do not logically belong inside a function.

Unlike a function file, a script file must *not* begin with the keyword `function`. If it does, Octave will assume that it is a function file, and that it defines a single function that should be evaluated as soon as it is defined.

A script file also differs from a function file in that the variables named in a script file are not local variables, but are in the same scope as the other variables that are visible on the command line.

Even though a script file may not begin with the `function` keyword, it is possible to define more than one function in a single script file and load (but not execute) all of them at once. To do this, the first token in the file (ignoring comments and other white space) must be something other than `function`. If you have no other statements to evaluate, you can use a statement that has no effect, like this:

```
# Prevent Octave from thinking that this
# is a function file:

1;

# Define function one:

function one ()
    ...
```

To have Octave read and compile these functions into an internal form, you need to make sure that the file is in Octave's `LOADPATH`, then simply type the base name of the file that contains the commands. (Octave uses the same rules to search for script files as it does to search for function files.)

If the first token in a file (ignoring comments) is `function`, Octave will compile the function and try to execute it, printing a message warning about any non-whitespace characters that appear after the function definition.

Note that Octave does not try to look up the definition of any identifier until it needs to evaluate it. This means that Octave will compile the following statements if they appear in a script file, or are typed at the command line,

```
# not a function file:
1;
function foo ()
    do_something ();
endfunction
function do_something ()
    do_something_else ();
endfunction
```

even though the function `do_something` is not defined before it is referenced in the function `foo`. This is not an error because Octave does not need to resolve all symbols that are referenced by a function until the function is actually evaluated.

Since Octave doesn't look for definitions until they are needed, the following code will always print `'bar = 3'` whether it is typed directly on the command line, read from a script file, or is part of a function body, even if there is a function or script file called `'bar.m'` in Octave's `LOADPATH`.

```
eval ("bar = 3");
bar
```

Code like this appearing within a function body could fool Octave if definitions were resolved as the function was being compiled. It would be virtually impossible to make Octave clever enough to evaluate this code in a consistent fashion. The parser would have to be able to perform the call to `eval` at compile time, and that would be impossible unless all the references in the string to be evaluated could also be resolved, and requiring that would be too restrictive (the string might come from user input, or depend on things that are not known until the function is evaluated).

Although Octave normally executes commands from script files that have the name `'file.m'`, you can use the function `source` to execute commands from any file.

source (*file*)

Built-in Function

Parse and execute the contents of *file*. This is equivalent to executing commands from a script file, but without requiring the file to be named '*file.m*'.

13.8 Dynamically Linked Functions

On some systems, Octave can dynamically load and execute functions written in C++. Octave can only directly call functions written in C++, but you can also load functions written in other languages by calling them from a simple wrapper function written in C++.

Here is an example of how to write a C++ function that Octave can load, with commentary. The source for this function is included in the source distributions of Octave, in the file '`examples/oregonator.cc`'. It defines the same set of differential equations that are used in the example problem of Section 23.1 [Ordinary Differential Equations], page 187. By running that example and this one, we can compare the execution times to see what sort of increase in speed you can expect by using dynamically linked functions.

The function defined in '`oregonator.cc`' contains just 8 statements, and is not much different than the code defined in the corresponding M-file (also distributed with Octave in the file '`examples/oregonator.m`').

Here is the complete text of '`oregonator.cc`':

```
just
#include <octave/oct.h>

DEFUN_DLD (oregonator, args, ,
  "The 'oregonator'.")
{
  ColumnVector dx (3);

  ColumnVector x (args(0).vector_value ());

  dx(0) = 77.27 * (x(1) - x(0)*x(1) + x(0)
    - 8.375e-06*pow (x(0), 2));

  dx(1) = (x(2) - x(0)*x(1) - x(1)) / 77.27;

  dx(2) = 0.161*(x(0) - x(2));

  return octave_value (dx);
}
```

The first line of the file,

```
#include <octave/oct.h>
```

includes declarations for all of Octave's internal functions that you will need. If you need other functions from the standard C++ or C libraries, you can include the necessary headers here.

The next two lines

```
DEFUN_DLD (oregonator, args, ,
  "The 'oregonator'.")
```

declares the function. The macro `DEFUN_DLD` and the macros that it depends on are defined in the files `'defun-dld.h'`, `'defun.h'`, and `'defun-int.h'` (these files are included in the header file `'octave/oct.h'`).

Note that the third parameter to `DEFUN_DLD` (`nargout`) is not used, so it is omitted from the list of arguments in order to avoid the warning from `gcc` about an unused function parameter.

The next line,

```
ColumnVector dx (3);
```

simply declares an object to store the right hand sides of the differential equation, and the statement

```
ColumnVector x (args(0).vector_value ());
```

extracts a vector from the first input argument. The `vector_value` method is used so that the user of the function can pass either a row or column vector. The `ColumnVector` constructor is needed because the ODE class requires a column vector. The variable `args` is passed to functions defined with `DEFUN_DLD` as an `octave_value_list` object, which includes methods for getting the length of the list and extracting individual elements.

In this example, we don't check for errors, but that is not difficult. All of the Octave's built-in functions do some form of checking on their arguments, so you can check the source code for those functions for examples of various strategies for verifying that the correct number and types of arguments have been supplied.

The next statements

```
dx(0) = 77.27 * (x(1) - x(0)*x(1) + x(0)
             - 8.375e-06*pow (x(0), 2));
```

```
dx(1) = (x(2) - x(0)*x(1) - x(1)) / 77.27;
```

```
dx(2) = 0.161*(x(0) - x(2));
```

define the right-hand side of the differential equation. Finally, we can return `dx`:

```
return octave_value (dx);
```

The actual return type is `octave_value_list`, but it is only necessary to convert the return type to an `octave_value` because there is a default constructor that can automatically create an object of that type from an `octave_value` object, so we can just use that instead.

To use this file, your version of Octave must support dynamic linking. To find out if it does, type the command `octave_config_info ("dld")` at the Octave prompt. Support for dynamic linking is included if this command returns 1.

To compile the example file, type the command `'mkoctfile oregonator.cc'` at the shell prompt. The script `mkoctfile` should have been installed along with Octave. Running it will create a file called `'oregonator.oct'` that can be loaded by Octave. To test the `'oregonator.oct'` file, start Octave and type the command

```
oregonator ([1, 2, 3], 0)
```

at the Octave prompt. Octave should respond by printing

```
ans =
    77.269353
   -0.012942
   -0.322000
```

You can now use the ‘`oregonator.oct`’ file just as you would the `oregonator.m` file to solve the set of differential equations.

On a 133 MHz Pentium running Linux, Octave can solve the problem shown in Section 23.1 [Ordinary Differential Equations], page 187, in about 1.4 seconds using the dynamically linked function, compared to about 19 seconds using the M-file. Similar decreases in execution time can be expected for other functions, particularly those that rely on functions like `lsode` that require user-supplied functions.

Just as for M-files, Octave will automatically reload a dynamically linked function when the file that defines it is more recent than the last time that the function was loaded. If more than one function is defined in a single ‘`.oct`’ file, reloading the file may force other functions to be cleared and reloaded. If all the functions loaded from a given ‘`.oct`’ file are cleared, Octave will automatically unload the ‘`.oct`’ file.

warn_reload_forces_clear

Built-in Variable

If several functions have been loaded from the same file, Octave must clear all the functions before any one of them can be reloaded. If `warn_reload_forces_clear`, Octave will warn you when this happens, and print a list of the additional functions that it is forced to clear.

variables_can_hide_functions

Built-in Variable

If the value of this variable is nonzero, assignments to variables may hide previously defined functions of the same name. A negative value will cause Octave to print a warning, but allow the operation.

Additional examples for writing dynamically linked functions are available in the files in the ‘`src`’ directory of the Octave distribution. Currently, this includes the files

```
balance.cc  fft2.cc      inv.cc       qzval.cc
chol.cc     filter.cc    log.cc       schur.cc
colloc.cc   find.cc      lsode.cc     sort.cc
dassl.cc    fsolve.cc   lu.cc        svd.cc
det.cc      givens.cc   minmax.cc    syl.cc
eig.cc     hess.cc     pinv.cc
expm.cc    ifft.cc     qr.cc
fft.cc     ifft2.cc    quad.cc
```

These files use the macro `DEFUN_DLD_BUILTIN` instead of `DEFUN_DLD`. The difference between these two macros is just that `DEFUN_DLD_BUILTIN` can define a built-in function that is not dynamically loaded if the operating system does not support dynamic linking. To define your own dynamically linked functions you should use `DEFUN_DLD`.

There is currently no detailed description of all the functions that you can call in a built-in function. For the time being, you will have to read the source code for Octave.

13.9 Function Handles and Inline

This is a place holder for the description of function handles and inline functions.

13.9.1 Function Handles

functions (*fcn_handle*) Built-in Function
Return a struct containing information about the function handle *fcn_handle*.

func2str (*fcn_handle*) Built-in Function
Return a string containing the name of the function referenced by the function handle *fcn_handle*.

str2func (*fcn_name*) Built-in Function
Return a function handle constructed from the string *fcn_name*.

13.9.2 Inline Functions

inline (*str*) Built-in Function
inline (*str*, *arg1*, ...) Built-in Function
inline (*str*, *n*) Built-in Function

Create an inline function from the character string *str*. If called with a single argument, the generated function is assumed to have a single argument and will be defined as the first isolated lower case character, except i or j.

If the second and subsequent arguments are character strings, they are the names of the arguments of the function.

If the second argument is an integer *n*, the arguments are "x", "P1", ..., "PN".

argnames (*fun*) Built-in Function
Return a cell array of character strings containing the names of the arguments of the inline function *fun*.

formula (*fun*) Built-in Function
Return a character string representing the inline function *fun*. Note that **char** (*fun*) is equivalent to **formula** (*fun*).

argnames (*fun*) Built-in Function
Create a vectorized version of the inline function *fun* by replacing all occurrences of *, /, etc., with .*, ./, etc.

13.10 Organization of Functions Distributed with Octave

Many of Octave's standard functions are distributed as function files. They are loosely organized by topic, in subdirectories of `'octave-home/lib/octave/version/m'`, to make it easier to find them.

The following is a list of all the function file subdirectories, and the types of functions you will find there.

- 'audio' Functions for playing and recording sounds.
- 'control' Functions for design and simulation of automatic control systems.
- 'elfun' Elementary functions.
- 'general' Miscellaneous matrix manipulations, like `flipud`, `rot90`, and `triu`, as well as other basic functions, like `ismatrix`, `nargchk`, etc.
- 'image' Image processing tools. These functions require the X Window System.
- 'io' Input-output functions.
- 'linear-algebra' Functions for linear algebra.
- 'miscellaneous' Functions that don't really belong anywhere else.
- 'plot' A set of functions that implement the MATLAB-like plotting functions.
- 'polynomial' Functions for manipulating polynomials.
- 'set' Functions for creating and manipulating sets of unique values.
- 'signal' Functions for signal processing applications.
- 'specfun' Special functions.
- 'special-matrix' Functions that create special matrix forms.
- 'startup' Octave's system-wide startup file.
- 'statistics' Statistical functions.
- 'strings' Miscellaneous string-handling functions.
- 'time' Functions related to time keeping.

14 Error Handling

Octave includes several functions for printing error and warning messages. When you write functions that need to take special action when they encounter abnormal conditions, you should print the error messages using the functions described in this chapter.

error (*template*, ...)

Built-in Function

The **error** function formats the optional arguments under the control of the template string *template* using the same rules as the **printf** family of functions (see Section 16.2.4 [Formatted Output], page 119). The resulting message is prefixed by the string `'error: '` and printed on the `stderr` stream.

Calling **error** also sets Octave's internal error state such that control will return to the top level without evaluating any more commands. This is useful for aborting from functions or scripts.

If the error message does not end with a new line character, Octave will print a traceback of all the function calls leading to the error. For example, given the following function definitions:

```
function f () g () end
function g () h () end
function h () nargin == 1 || error ("nargin != 1"); end
```

calling the function **f** will result in a list of messages that can help you to quickly locate the exact location of the error:

```
f ()
error: nargin != 1
error: evaluating index expression near line 1, column 30
error: evaluating binary operator '||' near line 1, column 27
error: called from 'h'
error: called from 'g'
error: called from 'f'
```

If the error message ends in a new line character, Octave will print the message but will not display any traceback messages as it returns control to the top level. For example, modifying the error message in the previous example to end in a new line causes Octave to only print a single message:

```
function h () nargin == 1 || error ("nargin != 1\n"); end
f ()
error: nargin != 1
```

beep_on_error

Built-in Variable

If the value of **beep_on_error** is nonzero, Octave will try to ring your terminal's bell before printing an error message. The default value is 0.

warning (*msg*)

Built-in Function

Print a warning message *msg* prefixed by the string `'warning: '`. After printing the warning message, Octave will continue to execute commands. You should use this function when you want to notify the user of an unusual condition, but only when it makes sense for your program to go on.

usage (*msg*) Built-in Function

Print the message *msg*, prefixed by the string ‘usage: ’, and set Octave’s internal error state such that control will return to the top level without evaluating any more commands. This is useful for aborting from functions.

After **usage** is evaluated, Octave will print a traceback of all the function calls leading to the usage message.

You should use this function for reporting problems errors that result from an improper call to a function, such as calling a function with an incorrect number of arguments, or with arguments of the wrong type. For example, most functions distributed with Octave begin with code like this

```
if (nargin != 2)
  usage ("foo (a, b)");
endif
```

to check for the proper number of arguments.

lasterr () Built-in Function

lasterr (*msg*) Built-in Function

Without any arguments, return the last error message. With one argument, set the last error message to *msg*.

lastwarn () Built-in Function

lastwarn (*msg*) Built-in Function

Without any arguments, return the last warning message. With one argument, set the last warning message to *msg*.

The following pair of functions are of limited usefulness, and may be removed from future versions of Octave.

perror (*name*, *num*) Function File

Print the error message for function *name* corresponding to the error number *num*. This function is intended to be used to print useful error messages for those functions that return numeric error codes.

strerror (*name*, *num*) Function File

Return the text of an error message for function *name* corresponding to the error number *num*. This function is intended to be used to print useful error messages for those functions that return numeric error codes.

15 Debugging

rline = dbstop (func, line) Loadable Function

Set a breakpoint in a function

func String representing the function name. When already in debug mode this should be left out and only the line should be given.

line Line you would like the breakpoint to be set on

The rline returned is the real line that the breakpoint was set at.

dbclear (func, line) Loadable Function

Delete a breakpoint in a function

func String representing the function name. When already in debug mode this should be left out and only the line should be given.

line Line where you would like to remove the the breakpoint

No checking is done to make sure that the line you requested is really a breakpoint. If you get the wrong line nothing will happen.

lst = dbstatus ([func]) Loadable Function

Return a vector containing the lines on which a function has breakpoints set.

func String representing the function name. When already in debug mode this should be left out.

dbwhere () Loadable Function

Show where we are in the code

dbtype () Loadable Function

List script file with line numbers.

debug_on_interrupt Built-in Variable

If **debug_on_interrupt** is nonzero, Octave will try to enter debugging mode when it receives an interrupt signal (typically generated with `C-c`). If a second interrupt signal is received before reaching the debugging mode, a normal interrupt will occur. The default value is 0.

debug_on_warning Built-in Variable

If the value of **debug_on_warning** is nonzero, Octave will try to enter the debugger when a warning is encountered. The default value is 0.

debug_on_error Built-in Variable

If the value of **debug_on_error** is nonzero, Octave will try to enter the debugger when an error is encountered. This will also inhibit printing of the normal traceback message (you will only see the top-level error message). The default value is 0.

16 Input and Output

There are two distinct classes of input and output functions. The first set are modeled after the functions available in MATLAB. The second set are modeled after the standard I/O library used by the C programming language and offer more flexibility and control over the output.

When running interactively, Octave normally sends any output intended for your terminal that is more than one screen long to a paging program, such as `less` or `more`. This avoids the problem of having a large volume of output stream by before you can read it. With `less` (and some versions of `more`) you can also scan forward and backward, and search for specific items.

Normally, no output is displayed by the pager until just before Octave is ready to print the top level prompt, or read from the standard input (for example, by using the `fscanf` or `scanf` functions). This means that there may be some delay before any output appears on your screen if you have asked Octave to perform a significant amount of work with a single command statement. The function `fflush` may be used to force output to be sent to the pager (or any other stream) immediately.

You can select the program to run as the pager by setting the variable `PAGER`, and you can turn paging off by setting the value of the variable `page_screen_output` to 0.

more	Command
more on	Command
more off	Command

Turn output pagination on or off. Without an argument, `more` toggles the current state.

PAGER	Built-in Variable
--------------	-------------------

The default value is normally "`less`", "`more`", or "`pg`", depending on what programs are installed on your system. See Appendix C [Installation], page 329.

When running interactively, Octave sends any output intended for your terminal that is more than one screen long to the program named by the value of the variable `PAGER`.

page_screen_output	Built-in Variable
---------------------------	-------------------

If the value of `page_screen_output` is nonzero, all output intended for the screen that is longer than one page is sent through a pager. This allows you to view one screenful at a time. Some pagers (such as `less`—see Appendix C [Installation], page 329) are also capable of moving backward on the output. The default value is 1.

page_output_immediately	Built-in Variable
--------------------------------	-------------------

If the value of `page_output_immediately` is nonzero, Octave sends output to the pager as soon as it is available. Otherwise, Octave buffers its output and waits until just before the prompt is printed to flush it to the pager. The default value is 0.

fflush (*fid*) Built-in Function

Flush output to *fid*. This is useful for ensuring that all pending output makes it to the screen before some other event occurs. For example, it is always a good idea to flush the standard output stream before calling `input`.

16.1 Basic Input and Output

16.1.1 Terminal Output

Since Octave normally prints the value of an expression as soon as it has been evaluated, the simplest of all I/O functions is a simple expression. For example, the following expression will display the value of `pi`

```
pi
+ pi = 3.1416
```

This works well as long as it is acceptable to have the name of the variable (or ‘`ans`’) printed along with the value. To print the value of a variable without printing its name, use the function `disp`.

The `format` command offers some control over the way Octave prints values with `disp` and through the normal echoing mechanism.

ans Built-in Variable

This variable holds the most recently computed result that was not explicitly assigned to a variable. For example, after the expression

```
3^2 + 4^2
```

is evaluated, the value of `ans` is 25.

fdisp (*fid*, *x*) Built-in Function

Display the value of *x* on the stream *fid*. For example,

```
fdisp (stdout, "The value of pi is:"), fdisp (stdout, pi)
```

```
+ the value of pi is:
+ 3.1416
```

Note that the output from `fdisp` always ends with a newline.

disp (*x*) Built-in Function

Display the value of *x*. For example,

```
disp ("The value of pi is:"), disp (pi)
```

```
+ the value of pi is:
+ 3.1416
```

Note that the output from `disp` always ends with a newline.

If an output value is requested, `disp` prints nothing and returns the formatted output in a string.

format options Command

Control the format of the output produced by `disp` and Octave's normal echoing mechanism. Valid options are listed in the following table.

short Octave will try to print numbers with at least 5 significant figures within a field that is a maximum of 10 characters wide (not counting additional spacing that is added between columns of a matrix).

If Octave is unable to format a matrix so that columns line up on the decimal point and all the numbers fit within the maximum field width, it switches to an 'e' format.

long Octave will try to print numbers with at least 15 significant figures within a field that is a maximum of 20 characters wide (not counting additional spacing that is added between columns of a matrix).

As will the 'short' format, Octave will switch to an 'e' format if it is unable to format a matrix so that columns line up on the decimal point and all the numbers fit within the maximum field width.

long e
short e The same as 'format long' or 'format short' but always display output with an 'e' format. For example, with the 'short e' format, `pi` is displayed as `3.14e+00`.

long E
short E The same as 'format long e' or 'format short e' but always display output with an uppercase 'E' format. For example, with the 'long E' format, `pi` is displayed as `3.14159265358979E+00`.

long g
short g Choose between normal 'long' (or 'short') and 'long e' (or 'short e') formats based on the magnitude of the number. For example, with the 'short g' format, `pi .^ [2; 4; 8; 16; 32]` is displayed as

```
ans =
      3.1416
      9.8696
     97.409
    9488.5
   9.0032e+07
  8.1058e+15
```

long G
short G The same as 'format long g' or 'format short g' but use an uppercase 'E' format. For example, with the 'short G' format, `pi .^ [2; 4; 8; 16; 32]` is displayed as

```

ans =
      3.1416
      9.8696
     97.409
    9488.5
   9.0032E+07
  8.1058E+15

```

free

none Print output in free format, without trying to line up columns of matrices on the decimal point. This also causes complex numbers to be formatted like this '(0.604194, 0.607088)' instead of like this '0.60419 + 0.60709i'.

bank Print in a fixed format with two places to the right of the decimal point.

+

+ chars

plus

plus chars

Print a '+' symbol for nonzero matrix elements and a space for zero matrix elements. This format can be very useful for examining the structure of a large matrix.

The optional argument *chars* specifies a list of 3 characters to use for printing values greater than zero, less than zero and equal to zero. For example, with the '+ "+-."' format, [1, 0, -1; -1, 0, 1] is displayed as

```

ans =
+.-
-.+

```

native-hex

Print the hexadecimal representation numbers as they are stored in memory. For example, on a workstation which stores 8 byte real values in IEEE format with the least significant byte first, the value of pi when printed in **hex** format is 400921fb54442d18. This format only works for numeric values.

hex The same as **native-hex**, but always print the most significant byte first.

native-bit

Print the bit representation of numbers as stored in memory. For example, the value of pi is

```

01000000000010010010000111111011
01010100010001000010110100011000

```

(shown here in two 32 bit sections for typesetting purposes) when printed in bit format on a workstation which stores 8 byte real values in IEEE format with the least significant byte first. This format only works for numeric types.

<code>bit</code>	The same as <code>native-bit</code> , but always print the most significant bits first.
<code>compact</code>	Remove extra blank space around column number labels.
<code>loose</code>	Insert blank lines above and below column number labels (this is the default).

By default, Octave will try to print numbers with at least 5 significant figures within a field that is a maximum of 10 characters wide.

If Octave is unable to format a matrix so that columns line up on the decimal point and all the numbers fit within the maximum field width, it switches to an ‘e’ format.

If `format` is invoked without any options, the default format state is restored.

print_answer_id_name Built-in Variable

If the value of `print_answer_id_name` is nonzero, variable names are printed along with the result. Otherwise, only the result values are printed. The default value is 1.

16.1.2 Terminal Input

Octave has three functions that make it easy to prompt users for input. The `input` and `menu` functions are normally used for managing an interactive dialog with a user, and the `keyboard` function is normally used for doing simple debugging.

input (*prompt*) Built-in Function

input (*prompt*, "s") Built-in Function

Print a prompt and wait for user input. For example,

```
input ("Pick a number, any number! ")
```

prints the prompt

```
Pick a number, any number!
```

and waits for the user to enter a value. The string entered by the user is evaluated as an expression, so it may be a literal constant, a variable name, or any other valid expression.

Currently, `input` only returns one value, regardless of the number of values produced by the evaluation of the expression.

If you are only interested in getting a literal string value, you can call `input` with the character string "s" as the second argument. This tells Octave to return the string entered by the user directly, without evaluating it first.

Because there may be output waiting to be displayed by the pager, it is a good idea to always call `fflush (stdout)` before calling `input`. This will ensure that all pending output is written to the screen before your prompt. See Chapter 16 [Input and Output], page 109.

menu (*title*, *opt1*, ...) Function File

Print a title string followed by a series of options. Each option will be printed along with a number. The return value is the number of the option selected by the user. This function is useful for interactive programs. There is no limit to the number of options that may be passed in, but it may be confusing to present more than will fit easily on one screen.

keyboard (*prompt*) Built-in Function

This function is normally used for simple debugging. When the **keyboard** function is executed, Octave prints a prompt and waits for user input. The input strings are then evaluated and the results are printed. This makes it possible to examine the values of variables within a function, and to assign new values to variables. No value is returned from the **keyboard** function, and it continues to prompt for input until the user types ‘quit’, or ‘exit’.

If **keyboard** is invoked without any arguments, a default prompt of ‘debug> ’ is used.

For both **input** and **keyboard**, the normal command line history and editing functions are available at the prompt.

Octave also has a function that makes it possible to get a single character from the keyboard without requiring the user to type a carriage return.

kbhit () Built-in Function

Read a single keystroke from the keyboard. If called with one argument, don’t wait for a keypress. For example,

```
x = kbhit ();
```

will set *x* to the next character typed at the keyboard as soon as it is typed.

```
x = kbhit (1);
```

identical to the above example, but don’t wait for a keypress, returning the empty string if no key is available.

16.1.3 Simple File I/O

The **save** and **load** commands allow data to be written to and read from disk files in various formats. The default format of files written by the **save** command can be controlled using the built-in variables **default_save_format** and **save_precision**.

Note that Octave cannot yet save or load structure variables or any user-defined types.

save *options file v1 v2 . . .* Command

Save the named variables *v1*, *v2*, . . . in the file *file*. The special filename ‘-’ can be used to write the output to your terminal. If no variable names are listed, Octave saves all the variables in the current scope. Valid options for the **save** command are listed in the following table. Options that modify the output format override the format specified by the built-in variable **default_save_format**.

-ascii Save the data in Octave’s text data format.

-binary Save the data in Octave’s binary data format.

-float-binary

Save the data in Octave’s binary data format but only using single precision. You should use this format only if you know that all the values to be saved can be represented in single precision.

-mat

-mat-binary

Save the data in MATLAB’s binary data format.

- mat4-binary** Save the data in the binary format written by MATLAB version 4.
- hdf5** Save the data in HDF5 format. (HDF5 is a free, portable binary format developed by the National Center for Supercomputing Applications at the University of Illinois.)
- float-hdf5** Save the data in HDF5 format but only using single precision. You should use this format only if you know that all the values to be saved can be represented in single precision.
- save-builtins** Force Octave to save the values of built-in variables too. By default, Octave does not save built-in variables.

The list of variables to save may include wildcard patterns containing the following special characters:

- ?** Match any single character.
- *** Match zero or more characters.
- [list]** Match the list of characters specified by *list*. If the first character is **!** or **^**, match all characters except those specified by *list*. For example, the pattern **'[a-zA-Z]'** will match all lower and upper case alphabetic characters.

Except when using the MATLAB binary data file format, saving global variables also saves the global status of the variable, so that if it is restored at a later time using **'load'**, it will be restored as a global variable.

The command

```
save -binary data a b*
```

saves the variable **'a'** and all variables beginning with **'b'** to the file **'data'** in Octave's binary format.

There are three variables that modify the behavior of **save** and three more that control whether variables are saved when Octave exits unexpectedly.

crash_dumps_octave_core Built-in Variable

If this variable is set to a nonzero value, Octave tries to save all current variables to the file "octave-core" if it crashes or receives a hangup, terminate or similar signal. The default value is 1.

sighup_dumps_octave_core Built-in Variable

If this variable is set to a nonzero value and **crash_dumps_octave_core** is also nonzero, Octave tries to save all current variables to the file "octave-core" if it receives a hangup signal. The default value is 1.

sigterm_dumps_octave_core Built-in Variable

If this variable is set to a nonzero value and `crash_dumps_octave_core` is also nonzero, Octave tries to save all current variables to the file "octave-core" if it receives a terminate signal. The default value is 1.

default_save_format Built-in Variable

This variable specifies the default format for the `save` command. It should have one of the following values: "ascii", "binary", "float-binary", or "mat-binary". The initial default save format is Octave's text format.

save_precision Built-in Variable

This variable specifies the number of digits to keep when saving data in text format. The default value is 17.

save_header_format_string Built-in Variable

This variable specifies the the format string for the comment line that is written at the beginning of text-format data files saved by Octave. The format string is passed to `strftime` and should begin with the character '#' and contain no newline characters. If the value of `save_header_format_string` is the empty string, the header comment is omitted from text-format data files. The default value is

```
"# Created by Octave VERSION, %a %b %d %H:%M:%S %Y %Z <USER@HOST>"
```

load *options file v1 v2 . . .* Command

Load the named variables from the file *file*. As with `save`, you may specify a list of variables and `load` will only extract those variables with names that match. For example, to restore the variables saved in the file 'data', use the command

```
load data
```

If a variable that is not marked as global is loaded from a file when a global symbol with the same name already exists, it is loaded in the global symbol table. Also, if a variable is marked as global in a file and a local symbol exists, the local symbol is moved to the global symbol table and given the value from the file. Since it seems that both of these cases are likely to be the result of some sort of error, they will generate warnings.

If invoked with a single output argument, Octave returns data instead of inserting variables in the symbol table. If the data file contains only numbers (TAB- or space-delimited columns), a matrix of values is returned. Otherwise, `load` returns a structure with members corresponding to the names of the variables in the file.

The `load` command can read data stored in Octave's text and binary formats, and MATLAB's binary format. It will automatically detect the type of file and do conversion from different floating point formats (currently only IEEE big and little endian, though other formats may be added in the future).

Valid options for `load` are listed in the following table.

- `-force` The ‘`-force`’ option is accepted but ignored for backward compatibility. Octave now overwrites variables currently in memory with the same name as those found in the file.
- `-ascii` Force Octave to assume the file is in Octave’s text format.
- `-binary` Force Octave to assume the file is in Octave’s binary format.
- `-mat`
- `-mat-binary` Force Octave to assume the file is in MATLAB’s binary format.
- `-mat4-binary` Force Octave to assume the file is in the binary format written by MATLAB version 4.
- `-hdf5` Force Octave to assume the file is in HDF5 format. (HDF5 is a free, portable binary format developed by the National Center for Supercomputing Applications at the University of Illinois.) Note that Octave can read HDF5 files not created by itself, but may skip some datasets in formats that it cannot support.
- `-import` The ‘`-import`’ is accepted but ignored for backward compatibility. Octave can now support multi-dimensional HDF data and automatically modifies variable names if they are invalid Octave identifiers.

16.2 C-Style I/O Functions

Octave’s C-style input and output functions provide most of the functionality of the C programming language’s standard I/O library. The argument lists for some of the input functions are slightly different, however, because Octave has no way of passing arguments by reference.

In the following, *file* refers to a file name and *fid* refers to an integer file number, as returned by `fopen`.

There are three files that are always available. Although these files can be accessed using their corresponding numeric file ids, you should always use the symbolic names given in the table below, since it will make your programs easier to understand.

stdin Built-in Variable

The standard input stream (file id 0). When Octave is used interactively, this is filtered through the command line editing functions.

stdout Built-in Variable

The standard output stream (file id 1). Data written to the standard output is normally filtered through the pager.

stderr Built-in Variable

The standard error stream (file id 2). Even if paging is turned on, the standard error is not sent to the pager. It is useful for error messages and prompts.

16.2.1 Opening and Closing Files

<code>[fid, msg] = fopen (name, mode, arch)</code>	Built-in Function
<code>fid_list = fopen ("all")</code>	Built-in Function
<code>file = fopen (fid)</code>	Built-in Function

The first form of the `fopen` function opens the named file with the specified mode (read-write, read-only, etc.) and architecture interpretation (IEEE big endian, IEEE little endian, etc.), and returns an integer value that may be used to refer to the file later. If an error occurs, `fid` is set to `-1` and `msg` contains the corresponding system error message. The `mode` is a one or two character string that specifies whether the file is to be opened for reading, writing, or both.

The second form of the `fopen` function returns a vector of file ids corresponding to all the currently open files, excluding the `stdin`, `stdout`, and `stderr` streams.

The third form of the `fopen` function returns the name of a currently open file given its file id.

For example,

```
myfile = fopen ("splat.dat", "r", "ieee-le");
```

opens the file `'splat.dat'` for reading. If necessary, binary numeric values will be read assuming they are stored in IEEE format with the least significant bit first, and then converted to the native representation.

Opening a file that is already open simply opens it again and returns a separate file id. It is not an error to open a file several times, though writing to the same file through several different file ids may produce unexpected results.

The possible values `'mode'` may have are

<code>'r'</code>	Open a file for reading.
<code>'w'</code>	Open a file for writing. The previous contents are discarded.
<code>'a'</code>	Open or create a file for writing at the end of the file.
<code>'r+'</code>	Open an existing file for reading and writing.
<code>'w+'</code>	Open a file for reading or writing. The previous contents are discarded.
<code>'a+'</code>	Open or create a file for reading or writing at the end of the file.

Append a `"t"` to the mode string to open the file in text mode or a `"b"` to open in binary mode. On Windows and Macintosh systems, text mode reading and writing automatically converts linefeeds to the appropriate line end character for the system (carriage-return linefeed on Windows, carriage-return on Macintosh). The default if no mode is specified is binary mode.

The parameter `arch` is a string specifying the default data format for the file. Valid values for `arch` are:

<code>'native'</code>	The format of the current machine (this is the default).
<code>'ieee-be'</code>	IEEE big endian format.
<code>'ieee-le'</code>	IEEE little endian format.

‘vaxd’ VAX D floating format.

‘vaxg’ VAX G floating format.

‘cray’ Cray floating format.

however, conversions are currently only supported for ‘native’ ‘ieee-be’, and ‘ieee-le’ formats.

fclose (*fid*) Built-in Function
 Closes the specified file. If successful, **fclose** returns 0, otherwise, it returns -1.

16.2.2 Simple Output

fputs (*fid*, *string*) Built-in Function
 Write a string to a file with no formatting.

puts (*string*) Built-in Function
 Write a string to the standard output with no formatting.

16.2.3 Line-Oriented Input

fgetl (*fid*, *len*) Built-in Function
 Read characters from a file, stopping after a newline, or EOF, or *len* characters have been read. The characters read, excluding the possible trailing newline, are returned as a string.
 If *len* is omitted, **fgetl** reads until the next newline character.
 If there are no more characters to read, **fgetl** returns -1.

fgets (*fid*, *len*) Built-in Function
 Read characters from a file, stopping after a newline, or EOF, or *len* characters have been read. The characters read, including the possible trailing newline, are returned as a string.
 If *len* is omitted, **fgets** reads until the next newline character.
 If there are no more characters to read, **fgets** returns -1.

16.2.4 Formatted Output

This section describes how to call **printf** and related functions.

The following functions are available for formatted output. They are modelled after the C language functions of the same name, but they interpret the format template differently in order to improve the performance of printing vector and matrix values.

printf (*fid*, *template*, ...) Built-in Function
 Print optional arguments under the control of the template string *template* to the stream **stdout**.

fprintf (*fid*, *template*, ...) Built-in Function
 This function is just like `printf`, except that the output is written to the stream *fid* instead of `stdout`.

sprintf (*template*, ...) Built-in Function
 This is like `printf`, except that the output is returned as a string. Unlike the C library function, which requires you to provide a suitably sized string as an argument, Octave's `sprintf` function returns the string, automatically sized to hold all of the items converted.

The `printf` function can be used to print any number of arguments. The template string argument you supply in a call provides information not only about the number of additional arguments, but also about their types and what style should be used for printing them.

Ordinary characters in the template string are simply written to the output stream as-is, while *conversion specifications* introduced by a `'%'` character in the template cause subsequent arguments to be formatted and written to the output stream. For example,

```
pct = 37;
filename = "foo.txt";
printf ("Processing of '%s' is %d%% finished.\nPlease be patient.\n",
        filename, pct);
```

produces output like

```
Processing of 'foo.txt' is 37% finished.
Please be patient.
```

This example shows the use of the `'%d'` conversion to specify that a scalar argument should be printed in decimal notation, the `'%s'` conversion to specify printing of a string argument, and the `'%%'` conversion to print a literal `'%'` character.

There are also conversions for printing an integer argument as an unsigned value in octal, decimal, or hexadecimal radix (`'%o'`, `'%u'`, or `'%x'`, respectively); or as a character value (`'%c'`).

Floating-point numbers can be printed in normal, fixed-point notation using the `'%f'` conversion or in exponential notation using the `'%e'` conversion. The `'%g'` conversion uses either `'%e'` or `'%f'` format, depending on what is more appropriate for the magnitude of the particular number.

You can control formatting more precisely by writing *modifiers* between the `'%'` and the character that indicates which conversion to apply. These slightly alter the ordinary behavior of the conversion. For example, most conversion specifications permit you to specify a minimum field width and a flag indicating whether you want the result left- or right-justified within the field.

The specific flags and modifiers that are permitted and their interpretation vary depending on the particular conversion. They're all described in more detail in the following sections.

16.2.5 Output Conversion for Matrices

When given a matrix value, Octave's formatted output functions cycle through the format template until all the values in the matrix have been printed. For example,

```
printf ("%4.2f %10.2e %8.4g\n", hilb (3));
```

```
→ 1.00    5.00e-01    0.3333
→ 0.50    3.33e-01     0.25
→ 0.33    2.50e-01     0.2
```

If more than one value is to be printed in a single call, the output functions do not return to the beginning of the format template when moving on from one value to the next. This can lead to confusing output if the number of elements in the matrices are not exact multiples of the number of conversions in the format template. For example,

```
printf ("%4.2f %10.2e %8.4g\n", [1, 2], [3, 4]);
```

```
→ 1.00    2.00e+00     3
→ 4.00
```

If this is not what you want, use a series of calls instead of just one.

16.2.6 Output Conversion Syntax

This section provides details about the precise syntax of conversion specifications that can appear in a `printf` template string.

Characters in the template string that are not part of a conversion specification are printed as-is to the output stream.

The conversion specifications in a `printf` template string have the general form:

```
% flags width [ . precision ] type conversion
```

For example, in the conversion specifier `%-10.8ld`, the `-` is a flag, `10` specifies the field width, the precision is `8`, the letter `l` is a type modifier, and `d` specifies the conversion style. (This particular type specifier says to print a numeric argument in decimal notation, with a minimum of 8 digits left-justified in a field at least 10 characters wide.)

In more detail, output conversion specifications consist of an initial `%` character followed in sequence by:

- Zero or more *flag characters* that modify the normal behavior of the conversion specification.
- An optional decimal integer specifying the *minimum field width*. If the normal conversion produces fewer characters than this, the field is padded with spaces to the specified width. This is a *minimum* value; if the normal conversion produces more characters than this, the field is *not* truncated. Normally, the output is right-justified within the field.

You can also specify a field width of `*`. This means that the next argument in the argument list (before the actual value to be printed) is used as the field width. The value is rounded to the nearest integer. If the value is negative, this means to set the `-` flag (see below) and to use the absolute value as the field width.

- An optional *precision* to specify the number of digits to be written for the numeric conversions. If the precision is specified, it consists of a period (‘.’) followed optionally by a decimal integer (which defaults to zero if omitted).

You can also specify a precision of ‘*’. This means that the next argument in the argument list (before the actual value to be printed) is used as the precision. The value must be an integer, and is ignored if it is negative.

- An optional *type modifier character*. This character is ignored by Octave’s `printf` function, but is recognized to provide compatibility with the C language `printf`.
- A character that specifies the conversion to be applied.

The exact options that are permitted and how they are interpreted vary between the different conversion specifiers. See the descriptions of the individual conversions for information about the particular options that they use.

16.2.7 Table of Output Conversions

Here is a table summarizing what all the different conversions do:

‘%d’, ‘%i’	Print an integer as a signed decimal number. See Section 16.2.8 [Integer Conversions], page 123, for details. ‘%d’ and ‘%i’ are synonymous for output, but are different when used with <code>scanf</code> for input (see Section 16.2.13 [Table of Input Conversions], page 126).
‘%o’	Print an integer as an unsigned octal number. See Section 16.2.8 [Integer Conversions], page 123, for details.
‘%u’	Print an integer as an unsigned decimal number. See Section 16.2.8 [Integer Conversions], page 123, for details.
‘%x’, ‘%X’	Print an integer as an unsigned hexadecimal number. ‘%x’ uses lower-case letters and ‘%X’ uses upper-case. See Section 16.2.8 [Integer Conversions], page 123, for details.
‘%f’	Print a floating-point number in normal (fixed-point) notation. See Section 16.2.9 [Floating-Point Conversions], page 123, for details.
‘%e’, ‘%E’	Print a floating-point number in exponential notation. ‘%e’ uses lower-case letters and ‘%E’ uses upper-case. See Section 16.2.9 [Floating-Point Conversions], page 123, for details.
‘%g’, ‘%G’	Print a floating-point number in either normal (fixed-point) or exponential notation, whichever is more appropriate for its magnitude. ‘%g’ uses lower-case letters and ‘%G’ uses upper-case. See Section 16.2.9 [Floating-Point Conversions], page 123, for details.
‘%c’	Print a single character. See Section 16.2.10 [Other Output Conversions], page 124.
‘%s’	Print a string. See Section 16.2.10 [Other Output Conversions], page 124.
‘%%’	Print a literal ‘%’ character. See Section 16.2.10 [Other Output Conversions], page 124.

If the syntax of a conversion specification is invalid, unpredictable things will happen, so don't do this. If there aren't enough function arguments provided to supply values for all the conversion specifications in the template string, or if the arguments are not of the correct types, the results are unpredictable. If you supply more arguments than conversion specifications, the extra argument values are simply ignored; this is sometimes useful.

16.2.8 Integer Conversions

This section describes the options for the `'%d'`, `'%i'`, `'%o'`, `'%u'`, `'%x'`, and `'%X'` conversion specifications. These conversions print integers in various formats.

The `'%d'` and `'%i'` conversion specifications both print an numeric argument as a signed decimal number; while `'%o'`, `'%u'`, and `'%x'` print the argument as an unsigned octal, decimal, or hexadecimal number (respectively). The `'%X'` conversion specification is just like `'%x'` except that it uses the characters `'ABCDEF'` as digits instead of `'abcdef'`.

The following flags are meaningful:

- `'-'` Left-justify the result in the field (instead of the normal right-justification).
- `'+'` For the signed `'%d'` and `'%i'` conversions, print a plus sign if the value is positive.
- `' '` For the signed `'%d'` and `'%i'` conversions, if the result doesn't start with a plus or minus sign, prefix it with a space character instead. Since the `'+'` flag ensures that the result includes a sign, this flag is ignored if you supply both of them.
- `'#'` For the `'%o'` conversion, this forces the leading digit to be `'0'`, as if by increasing the precision. For `'%x'` or `'%X'`, this prefixes a leading `'0x'` or `'0X'` (respectively) to the result. This doesn't do anything useful for the `'%d'`, `'%i'`, or `'%u'` conversions.
- `'0'` Pad the field with zeros instead of spaces. The zeros are placed after any indication of sign or base. This flag is ignored if the `'-'` flag is also specified, or if a precision is specified.

If a precision is supplied, it specifies the minimum number of digits to appear; leading zeros are produced if necessary. If you don't specify a precision, the number is printed with as many digits as it needs. If you convert a value of zero with an explicit precision of zero, then no characters at all are produced.

16.2.9 Floating-Point Conversions

This section discusses the conversion specifications for floating-point numbers: the `'%f'`, `'%e'`, `'%E'`, `'%g'`, and `'%G'` conversions.

The `'%f'` conversion prints its argument in fixed-point notation, producing output of the form `[-]ddd.ddd`, where the number of digits following the decimal point is controlled by the precision you specify.

The `'%e'` conversion prints its argument in exponential notation, producing output of the form `[-]d.ddde[+|-]dd`. Again, the number of digits following the decimal point is controlled by the precision. The exponent always contains at least two digits. The `'%E'` conversion is similar but the exponent is marked with the letter `'E'` instead of `'e'`.

The `'%g'` and `'%G'` conversions print the argument in the style of `'%e'` or `'%E'` (respectively) if the exponent would be less than -4 or greater than or equal to the precision; otherwise

they use the ‘%f’ style. Trailing zeros are removed from the fractional portion of the result and a decimal-point character appears only if it is followed by a digit.

The following flags can be used to modify the behavior:

- ‘-’ Left-justify the result in the field. Normally the result is right-justified.
- ‘+’ Always include a plus or minus sign in the result.
- ‘ ’ If the result doesn’t start with a plus or minus sign, prefix it with a space instead. Since the ‘+’ flag ensures that the result includes a sign, this flag is ignored if you supply both of them.
- ‘#’ Specifies that the result should always include a decimal point, even if no digits follow it. For the ‘%g’ and ‘%G’ conversions, this also forces trailing zeros after the decimal point to be left in place where they would otherwise be removed.
- ‘0’ Pad the field with zeros instead of spaces; the zeros are placed after any sign. This flag is ignored if the ‘-’ flag is also specified.

The precision specifies how many digits follow the decimal-point character for the ‘%f’, ‘%e’, and ‘%E’ conversions. For these conversions, the default precision is 6. If the precision is explicitly 0, this suppresses the decimal point character entirely. For the ‘%g’ and ‘%G’ conversions, the precision specifies how many significant digits to print. Significant digits are the first digit before the decimal point, and all the digits after it. If the precision is 0 or not specified for ‘%g’ or ‘%G’, it is treated like a value of 1. If the value being printed cannot be expressed precisely in the specified number of digits, the value is rounded to the nearest number that fits.

16.2.10 Other Output Conversions

This section describes miscellaneous conversions for `printf`.

The ‘%c’ conversion prints a single character. The ‘-’ flag can be used to specify left-justification in the field, but no other flags are defined, and no precision or type modifier can be given. For example:

```
printf ("%c%c%c%c%c", "h", "e", "l", "l", "o");
prints 'hello'.
```

The ‘%s’ conversion prints a string. The corresponding argument must be a string. A precision can be specified to indicate the maximum number of characters to write; otherwise characters in the string up to but not including the terminating null character are written to the output stream. The ‘-’ flag can be used to specify left-justification in the field, but no other flags or type modifiers are defined for this conversion. For example:

```
printf ("%3s%-6s", "no", "where");
prints ' nowhere ' (note the leading and trailing spaces).
```

16.2.11 Formatted Input

Octave provides the `scanf`, `fscanf`, and `sscanf` functions to read formatted input. There are two forms of each of these functions. One can be used to extract vectors of data from a file, and the other is more ‘C-like’.

$[val, count] = \mathbf{fscanf} (fid, template, size)$ Built-in Function
 $[v1, v2, \dots, count] = \mathbf{fscanf} (fid, template, "C")$ Built-in Function

In the first form, read from *fid* according to *template*, returning the result in the matrix *val*.

The optional argument *size* specifies the amount of data to read and may be one of

Inf Read as much as possible, returning a column vector.

nr Read up to *nr* elements, returning a column vector.

$[nr, \mathbf{Inf}]$ Read as much as possible, returning a matrix with *nr* rows. If the number of elements read is not an exact multiple of *nr*, the last column is padded with zeros.

$[nr, nc]$ Read up to $nr * nc$ elements, returning a matrix with *nr* rows. If the number of elements read is not an exact multiple of *nr*, the last column is padded with zeros.

If *size* is omitted, a value of **Inf** is assumed.

A string is returned if *template* specifies only character conversions.

The number of items successfully read is returned in *count*.

In the second form, read from *fid* according to *template*, with each conversion specifier in *template* corresponding to a single scalar return value. This form is more ‘C-like’, and also compatible with previous versions of Octave. The number of successful conversions is returned in *count*

$[val, count] = \mathbf{sscanf} (string, template, size)$ Built-in Function
 $[v1, v2, \dots, count] = \mathbf{sscanf} (string, template, "C")$ Built-in Function

This is like **fscanf**, except that the characters are taken from the string *string* instead of from a stream. Reaching the end of the string is treated as an end-of-file condition.

Calls to **scanf** are superficially similar to calls to **printf** in that arbitrary arguments are read under the control of a template string. While the syntax of the conversion specifications in the template is very similar to that for **printf**, the interpretation of the template is oriented more towards free-format input and simple pattern matching, rather than fixed-field formatting. For example, most **scanf** conversions skip over any amount of “white space” (including spaces, tabs, and newlines) in the input file, and there is no concept of precision for the numeric input conversions as there is for the corresponding output conversions. Ordinarily, non-whitespace characters in the template are expected to match characters in the input stream exactly.

When a *matching failure* occurs, **scanf** returns immediately, leaving the first non-matching character as the next character to be read from the stream, and **scanf** returns all the items that were successfully converted.

The formatted input functions are not used as frequently as the formatted output functions. Partly, this is because it takes some care to use them properly. Another reason is that it is difficult to recover from a matching error.

16.2.12 Input Conversion Syntax

A `scanf` template string is a string that contains ordinary multibyte characters interspersed with conversion specifications that start with ‘%’.

Any whitespace character in the template causes any number of whitespace characters in the input stream to be read and discarded. The whitespace characters that are matched need not be exactly the same whitespace characters that appear in the template string. For example, write ‘ , ’ in the template to recognize a comma with optional whitespace before and after.

Other characters in the template string that are not part of conversion specifications must match characters in the input stream exactly; if this is not the case, a matching failure occurs.

The conversion specifications in a `scanf` template string have the general form:

```
% flags width type conversion
```

In more detail, an input conversion specification consists of an initial ‘%’ character followed in sequence by:

- An optional *flag character* ‘*’, which says to ignore the text read for this specification. When `scanf` finds a conversion specification that uses this flag, it reads input as directed by the rest of the conversion specification, but it discards this input, does not return any value, and does not increment the count of successful assignments.
- An optional decimal integer that specifies the *maximum field width*. Reading of characters from the input stream stops either when this maximum is reached or when a non-matching character is found, whichever happens first. Most conversions discard initial whitespace characters, and these discarded characters don’t count towards the maximum field width. Conversions that do not discard initial whitespace are explicitly documented.
- An optional type modifier character. This character is ignored by Octave’s `scanf` function, but is recognized to provide compatibility with the C language `scanf`.
- A character that specifies the conversion to be applied.

The exact options that are permitted and how they are interpreted vary between the different conversion specifiers. See the descriptions of the individual conversions for information about the particular options that they allow.

16.2.13 Table of Input Conversions

Here is a table that summarizes the various conversion specifications:

‘%d’	Matches an optionally signed integer written in decimal. See Section 16.2.14 [Numeric Input Conversions], page 127.
‘%i’	Matches an optionally signed integer in any of the formats that the C language defines for specifying an integer constant. See Section 16.2.14 [Numeric Input Conversions], page 127.
‘%o’	Matches an unsigned integer written in octal radix. See Section 16.2.14 [Numeric Input Conversions], page 127.

<code>'%u'</code>	Matches an unsigned integer written in decimal radix. See Section 16.2.14 [Numeric Input Conversions], page 127.
<code>'%x', '%X'</code>	Matches an unsigned integer written in hexadecimal radix. See Section 16.2.14 [Numeric Input Conversions], page 127.
<code>'%e', '%f', '%g', '%E', '%G'</code>	Matches an optionally signed floating-point number. See Section 16.2.14 [Numeric Input Conversions], page 127.
<code>'%s'</code>	Matches a string containing only non-whitespace characters. See Section 16.2.15 [String Input Conversions], page 127.
<code>'%c'</code>	Matches a string of one or more characters; the number of characters read is controlled by the maximum field width given for the conversion. See Section 16.2.15 [String Input Conversions], page 127.
<code>'%%'</code>	This matches a literal <code>'%'</code> character in the input stream. No corresponding argument is used.

If the syntax of a conversion specification is invalid, the behavior is undefined. If there aren't enough function arguments provided to supply addresses for all the conversion specifications in the template strings that perform assignments, or if the arguments are not of the correct types, the behavior is also undefined. On the other hand, extra arguments are simply ignored.

16.2.14 Numeric Input Conversions

This section describes the `scanf` conversions for reading numeric values.

The `'%d'` conversion matches an optionally signed integer in decimal radix.

The `'%i'` conversion matches an optionally signed integer in any of the formats that the C language defines for specifying an integer constant.

For example, any of the strings `'10'`, `'0xa'`, or `'012'` could be read in as integers under the `'%i'` conversion. Each of these specifies a number with decimal value 10.

The `'%o'`, `'%u'`, and `'%x'` conversions match unsigned integers in octal, decimal, and hexadecimal radices, respectively.

The `'%X'` conversion is identical to the `'%x'` conversion. They both permit either uppercase or lowercase letters to be used as digits.

Unlike the C language `scanf`, Octave ignores the `'h'`, `'l'`, and `'L'` modifiers.

16.2.15 String Input Conversions

This section describes the `scanf` input conversions for reading string and character values: `'%s'` and `'%c'`.

The `'%c'` conversion is the simplest: it matches a fixed number of characters, always. The maximum field width says how many characters to read; if you don't specify the maximum, the default is 1. This conversion does not skip over initial whitespace characters. It reads precisely the next n characters, and fails if it cannot get that many.

The ‘%s’ conversion matches a string of non-whitespace characters. It skips and discards initial whitespace, but stops when it encounters more whitespace after having read something.

For example, reading the input:

```
hello, world
```

with the conversion ‘%10c’ produces "hello, wo", but reading the same input with the conversion ‘%10s’ produces "hello,".

16.2.16 Binary I/O

Octave can read and write binary data using the functions `fread` and `fwrite`, which are patterned after the standard C functions with the same names. They are able to automatically swap the byte order of integer data and convert among the supported floating point formats as the data are read.

[*val*, *count*] = **fread** (*fid*, *size*, *precision*, *skip*, *arch*) Built-in Function

Read binary data of type *precision* from the specified file ID *fid*.

The optional argument *size* specifies the amount of data to read and may be one of

Inf Read as much as possible, returning a column vector.

nr Read up to *nr* elements, returning a column vector.

[*nr*, **Inf**] Read as much as possible, returning a matrix with *nr* rows. If the number of elements read is not an exact multiple of *nr*, the last column is padded with zeros.

[*nr*, *nc*] Read up to *nr* * *nc* elements, returning a matrix with *nr* rows. If the number of elements read is not an exact multiple of *nr*, the last column is padded with zeros.

If *size* is omitted, a value of **Inf** is assumed.

The optional argument *precision* is a string specifying the type of data to read and may be one of

"schar"

"signed char"

Signed character.

"uchar"

"unsigned char"

Unsigned character.

"int8"

"integer*1"

8-bit signed integer.

"int16"

"integer*2"

16-bit signed integer.

```

"int32"
"integer*4"      32-bit signed integer.

"int64"
"integer*8"      64-bit signed integer.

"uint8"          8-bit unsigned integer.
"uint16"         16-bit unsigned integer.
"uint32"         32-bit unsigned integer.
"uint64"         64-bit unsigned integer.

"single"
"float32"
"real*4"         32-bit floating point number.

"double"
"float64"
"real*8"         64-bit floating point number.

"char"
"char*1"         Single character.

"short"          Short integer (size is platform dependent).
"int"            Integer (size is platform dependent).
"long"           Long integer (size is platform dependent).

"ushort"
"unsigned short" Unsigned short integer (size is platform dependent).

"uint"
"unsigned int"   Unsigned integer (size is platform dependent).

"ulong"
"unsigned long"  Unsigned long integer (size is platform dependent).

"float"          Single precision floating point number (size is platform dependent).

```

The default precision is "uchar".

The *precision* argument may also specify an optional repeat count. For example, '32*single' causes `fread` to read a block of 32 single precision floating point numbers. Reading in blocks is useful in combination with the *skip* argument.

The *precision* argument may also specify a type conversion. For example, 'int16=>int32' causes `fread` to read 16-bit integer values and return an array of 32-bit integer values. By default, `fread` returns a double precision array. The special form '*TYPE' is shorthand for 'TYPE=>TYPE'.

The conversion and repeat counts may be combined. For example, '32*single=>single' causes `fread` to read blocks of single precision floating point values and return an array of single precision values instead of the default array of double precision values.

The optional argument *skip* specifies the number of bytes to skip after each element (or block of elements) is read. If it is not specified, a value of 0 is assumed. If the final block read is not complete, the final skip is omitted. For example,

```
fread (f, 10, "3*single=>single", 8)
```

will omit the final 8-byte skip because the last read will not be a complete block of 3 values.

The optional argument *arch* is a string specifying the data format for the file. Valid values are

"native" The format of the current machine.

"ieee-be" IEEE big endian.

"ieee-le" IEEE little endian.

"vaxd" VAX D floating format.

"vaxg" VAX G floating format.

"cray" Cray floating format.

Conversions are currently only supported for "ieee-be" and "ieee-le" formats.

The data read from the file is returned in *val*, and the number of values read is returned in *count*

count = **fwrite** (*fid*, *data*, *precision*, *skip*, *arch*) Built-in Function

Write data in binary form of type *precision* to the specified file ID *fid*, returning the number of values successfully written to the file.

The argument *data* is a matrix of values that are to be written to the file. The values are extracted in column-major order.

The remaining arguments *precision*, *skip*, and *arch* are optional, and are interpreted as described for `fread`.

The behavior of `fwrite` is undefined if the values in *data* are too large to fit in the specified precision.

16.2.17 Temporary Files

[*fid*, *name*, *msg*] = **tmpfile** (*template*, *delete*) Built-in Function

Return the file ID corresponding to a new temporary file with a unique name created from *template*. The last six characters of *template* must be `XXXXXX` and these are replaced with a string that makes the filename unique. The file is then created with mode read/write and permissions that are system dependent (on GNU/Linux systems,

the permissions will be 0600 for versions of glibc 2.0.7 and later). The file is opened with the `O_EXCL` flag.

If the optional argument *delete* is supplied and is true, the file will be deleted automatically when Octave exits, or when the function `purge_tmp_files` is called.

If successful, *fid* is a valid file ID, *name* is the name of the file, and *msg* is an empty string. Otherwise, *fid* is -1, *name* is empty, and *msg* contains a system-dependent error message.

`[fid, msg] = tmpfile ()` Built-in Function

Return the file ID corresponding to a new temporary file with a unique name. The file is opened in binary read/write ("`w+b`") mode. The file will be deleted automatically when it is closed or when Octave exits.

If successful, *fid* is a valid file ID and *msg* is an empty string. Otherwise, *fid* is -1 and *msg* contains a system-dependent error message.

`tmpnam (dir, prefix)` Built-in Function

Return a unique temporary file name as a string.

If *prefix* is omitted, a value of "`oct-`" is used. If *dir* is also omitted, the default directory for temporary files is used. If *dir* is provided, it must exist, otherwise the default directory for temporary files is used. Since the named file is not opened, by `tmpnam`, it is possible (though relatively unlikely) that it will not be available by the time your program attempts to open it.

16.2.18 End of File and Errors

`feof (fid)` Built-in Function

Return 1 if an end-of-file condition has been encountered for a given file and 0 otherwise. Note that it will only return 1 if the end of the file has already been encountered, not if the next read operation will result in an end-of-file condition.

`ferror (fid)` Built-in Function

Return 1 if an error condition has been encountered for a given file and 0 otherwise. Note that it will only return 1 if an error has already been encountered, not if the next operation will result in an error condition.

`freport ()` Built-in Function

Print a list of which files have been opened, and whether they are open for reading, writing, or both. For example,

```
freport ()
+ number mode name
+
+      0    r stdin
+      1    w stdout
+      2    w stderr
+      3    r myfile
```

16.2.19 File Positioning

Three functions are available for setting and determining the position of the file pointer for a given file.

ftell (*fid*) Built-in Function
 Return the position of the file pointer as the number of characters from the beginning of the file *fid*.

fseek (*fid*, *offset*, *origin*) Built-in Function
 Set the file pointer to any location within the file *fid*. The pointer is positioned *offset* characters from the *origin*, which may be one of the predefined variables `SEEK_CUR` (current position), `SEEK_SET` (beginning), or `SEEK_END` (end of file). If *origin* is omitted, `SEEK_SET` is assumed. The offset must be zero, or a value returned by `ftell` (in which case *origin* must be `SEEK_SET`).

SEEK_SET Built-in Variable
SEEK_CUR Built-in Variable
SEEK_END Built-in Variable

These variables may be used as the optional third argument for the function `fseek`.

`SEEK_SET` Position file relative to the beginning.

`SEEK_CUR` Position file relative to the current position.

`SEEK_END` used with `fseek` to position file relative to the end.

frewind (*fid*) Built-in Function
 Move the file pointer to the beginning of the file *fid*, returning 0 for success, and -1 if an error was encountered. It is equivalent to `fseek (fid, 0, SEEK_SET)`.

The following example stores the current file position in the variable `marker`, moves the pointer to the beginning of the file, reads four characters, and then returns to the original position.

```
marker = ftell (myfile);
frewind (myfile);
fourch = fgets (myfile, 4);
fseek (myfile, marker, SEEK_SET);
```

17 Plotting

All of Octave's plotting functions use `gnuplot` to handle the actual graphics. There are two low-level functions, `gplot` and `gsplot`, that behave almost exactly like the corresponding `gnuplot` functions `plot` and `splot`. A number of other higher level plotting functions, patterned after the graphics functions found in MATLAB version 3.5, are also available. These higher level functions are all implemented in terms of the two low-level plotting functions.

17.1 Two-Dimensional Plotting

gplot *ranges expression using title style* Command
Generate a 2-dimensional plot.

The *ranges*, *using*, *title*, and *style* arguments are optional, and the *using*, *title* and *style* qualifiers may appear in any order after the expression. You may plot multiple expressions with a single command by separating them with commas. Each expression may have its own set of qualifiers.

The optional item *ranges* has the syntax

```
[ x_lo : x_up ] [ y_lo : y_up ]
```

and may be used to specify the ranges for the axes of the plot, independent of the actual range of the data. The range for the y axis and any of the individual limits may be omitted. A range `[:]` indicates that the default limits should be used. This normally means that a range just large enough to include all the data points will be used.

The expression to be plotted must not contain any literal matrices (e.g. `[1, 2; 3, 4]`) since it is nearly impossible to distinguish a plot range from a matrix of data.

See the help for `gnuplot` for a description of the syntax for the optional items.

By default, the `gplot` command plots the second column of a matrix versus the first. If the matrix only has one column, it is taken as a vector of y-coordinates and the x-coordinate is taken as the element index, starting with zero. For example,

```
gplot rand (100,1) with linespoints
```

will plot 100 random values and connect them with lines. When `gplot` is used to plot a column vector, the indices of the elements are taken as x values.

If there are more than two columns, you can choose which columns to plot with the *using* qualifier. For example, given the data

```
x = (-10:0.1:10)';
data = [x, sin(x), cos(x)];
```

the command

```
gplot [-11:11] [-1.1:1.1] \
  data with lines, data using 1:3 with impulses
```

will plot two lines. The first line is generated by the command `data with lines`, and is a graph of the sine function over the range -10 to 10 . The data is taken from the

first two columns of the matrix because columns to plot were not specified with the *using* qualifier.

The clause `using 1:3` in the second part of this plot command specifies that the first and third columns of the matrix `data` should be taken as the values to plot.

In this example, the ranges have been explicitly specified to be a bit larger than the actual range of the data so that the curves do not touch the border of the plot.

gset <i>options</i>	Command
gshow <i>options</i>	Command
replot <i>options</i>	Command

In addition to the basic plotting commands, the whole range of `gset` and `gshow` commands from `gnuplot` are available, as is `replot`.

Note that in Octave 2.0, the `set` and `show` commands were renamed to `gset` and `gshow` in order to allow for compatibility with the MATLAB graphics and GUI commands in a future version of Octave. (For now, the old `set` and `show` commands do work, but they print an annoying warning message to try to get people to switch to using `gset` and `gshow`.)

The `gset` and `gshow` commands allow you to set and show `gnuplot` parameters. For more information about the `gset` and `gshow` commands, see the documentation for `set` and `show` in the `gnuplot` user's guide (also available on line if you run `gnuplot` directly, instead of running it from Octave).

The `replot` command allows you to force the plot to be redisplayed. This is useful if you have changed something about the plot, such as the title or axis labels. The `replot` command also accepts the same arguments as `gplot` or `gsplot` (except for data ranges) so you can add additional lines to existing plots.

For example,

```
gset term tek40
gset output "/dev/plotter"
gset title "sine with lines and cosine with impulses"
replot "sin (x) w l"
```

will change the terminal type for plotting, add a title to the current plot, add a graph of $\sin(x)$ to the plot, and force the new plot to be sent to the plot device. This last step is normally required in order to update the plot. This default is reasonable for slow terminals or hardcopy output devices because even when you are adding additional lines with a `replot` command, `gnuplot` always redraws the entire plot, and you probably don't want to have a completely new plot generated every time something as minor as an axis label changes.

The command `shg` is equivalent to executing `replot` without any arguments.

automatic_replot	Built-in Variable
-------------------------	-------------------

You can tell Octave to redisplay the plot each time anything about it changes by setting the value of the builtin variable `automatic_replot` to a nonzero value. Although it is fairly inefficient, especially for large plots, the default value is 1 for compatibility with Matlab.

Note that NaN values in the plot data are automatically omitted, and Inf values are converted to a very large value before calling gnuplot.

The MATLAB-style two-dimensional plotting commands are:

plot (*args*) Function File

This function produces two-dimensional plots. Many different combinations of arguments are possible. The simplest form is

```
plot (y)
```

where the argument is taken as the set of *y* coordinates and the *x* coordinates are taken to be the indices of the elements, starting with 1.

If more than one argument is given, they are interpreted as

```
plot (x, y, fmt ...)
```

where *y* and *fmt* are optional, and any number of argument sets may appear. The *x* and *y* values are interpreted as follows:

- If a single data argument is supplied, it is taken as the set of *y* coordinates and the *x* coordinates are taken to be the indices of the elements, starting with 1.
- If the first argument is a vector and the second is a matrix, the the vector is plotted versus the columns (or rows) of the matrix. (using whichever combination matches, with columns tried first.)
- If the first argument is a matrix and the second is a vector, the the columns (or rows) of the matrix are plotted versus the vector. (using whichever combination matches, with columns tried first.)
- If both arguments are vectors, the elements of *y* are plotted versus the elements of *x*.
- If both arguments are matrices, the columns of *y* are plotted versus the columns of *x*. In this case, both matrices must have the same number of rows and columns and no attempt is made to transpose the arguments to make the number of rows match.

If both arguments are scalars, a single point is plotted.

If the *fmt* argument is supplied, it is interpreted as follows. If *fmt* is missing, the default gnuplot line style is assumed.

- ‘-’ Set lines plot style (default).
- ‘.’ Set dots plot style.
- ‘@’ Set points plot style.
- ‘-@’ Set linespoints plot style.
- ‘^’ Set impulses plot style.
- ‘L’ Set steps plot style.
- ‘*n*’ Interpreted as the plot color if *n* is an integer in the range 1 to 6.
- ‘*nm*’ If *nm* is a two digit integer and *m* is an integer in the range 1 to 6, *m* is interpreted as the point style. This is only valid in combination with the @ or -@ specifiers.

'c' If *c* is one of "r", "g", "b", "m", "c", or "w", it is interpreted as the plot color (red, green, blue, magenta, cyan, or white).

";title;" Here "title" is the label for the key.

'+'

'*'

'o'

'x' Used in combination with the points or linespoints styles, set the point style.

The color line styles have the following meanings on terminals that support color.

Number	Gnuplot colors	(lines)points style
1	red	*
2	green	+
3	blue	o
4	magenta	x
5	cyan	house
6	brown	there exists

The *fmt* argument can also be used to assign key titles. To do so, include the desired title between semi-colons after the formatting sequence described above, e.g. "+3;Key Title;" Note that the last semi-colon is required and will generate an error if it is left out.

Here are some plot examples:

```
plot (x, y, "@12", x, y2, x, y3, "4", x, y4, "+")
```

This command will plot *y* with points of type 2 (displayed as '+') and color 1 (red), *y2* with lines, *y3* with lines of color 4 (magenta) and *y4* with points displayed as '+'.

```
plot (b, "*")
```

```
plot (b, "*")
```

This command will plot the data in the variable *b* will be plotted with points displayed as '*'.

```
t = 0:0.1:6.3;
plot (t, cos(t), "-;cos(t);", t, sin(t), "+3;sin(t);");
```

```
t = 0:0.1:6.3;
plot (t, cos(t), "-;cos(t);", t, sin(t), "+3;sin(t);");
```

This will plot the cosine and sine functions and label them accordingly in the key.

hold args

Built-in Function

Tell Octave to 'hold' the current data on the plot when executing subsequent plotting commands. This allows you to execute a series of plot commands and have all the lines end up on the same figure. The default is for each new plot command to clear the plot device first. For example, the command

```
hold on
```

turns the hold state on. An argument of *off* turns the hold state off, and *hold* with no arguments toggles the current hold state.

ishold

Built-in Function

Return 1 if the next line will be added to the current plot, or 0 if the plot device will be cleared before drawing the next line.

clearplot Built-in Function
clg Built-in Function

Clear the plot window and any titles or axis labels. The name `clg` is aliased to `clearplot` for compatibility with MATLAB.

The commands `gplot clear`, `gsplot clear`, and `replot clear` are equivalent to `clearplot`. (Previously, commands like `gplot clear` would evaluate `clear` as an ordinary expression and clear all the visible variables.)

shg Function File

Show the graph window. Currently, this is the same as executing `replot` without any arguments.

closeplot Built-in Function

Close stream to the `gnuplot` subprocess. If you are using X11, this will close the plot window.

purge_tmp_files Built-in Function

Delete the temporary files created by the plotting commands.

Octave creates temporary data files for `gnuplot` and then sends commands to `gnuplot` through a pipe. Octave will delete the temporary files on exit, but if you are doing a lot of plotting you may want to clean up in the middle of a session.

A future version of Octave will eliminate the need to use temporary files to hold the plot data.

axis (*limits*) Function File

Set axis limits for plots.

The argument *limits* should be a 2, 4, or 6 element vector. The first and second elements specify the lower and upper limits for the x axis. The third and fourth specify the limits for the y axis, and the fifth and sixth specify the limits for the z axis.

If your plot is already drawn, then you need to use `replot` before the new axis limits will take effect. You can get this to happen automatically by setting the built-in variable `automatic_replot` to a nonzero value.

Without any arguments, `axis` turns autoscaling on.

With one output argument, `x=axis` returns the current axes (this is not yet implemented for automatic axes).

The vector argument specifying limits is optional, and additional string arguments may be used to specify various axis properties. For example,

```
axis ([1, 2, 3, 4], "square");
```

forces a square aspect ratio, and

```
axis ("labely", "tic");
```

turns tic marks on for all axes and tic mark labels on for the y-axis only.

The following options control the aspect ratio of the axes.

"square" Force a square aspect ratio.

"equal" Force x distance to equal y-distance.

"normal" Restore the balance.

The following options control the way axis limits are interpreted.

"auto" Set the specified axes to have nice limits around the data or all if no axes are specified.

"manual" Fix the current axes limits.

"tight" Fix axes to the limits of the data (not implemented).

The option "image" is equivalent to "tight" and "equal".

The following options affect the appearance of tic marks.

"on" Turn tic marks and labels on for all axes.

"off" Turn tic marks off for all axes.

"tic[xyz]"
Turn tic marks on for all axes, or turn them on for the specified axes and off for the remainder.

"label[xyz]"
Turn tic labels on for all axes, or turn them on for the specified axes and off for the remainder.

"nolabel"
Turn tic labels off for all axes.

Note, if there are no tic marks for an axis, there can be no labels.

The following options affect the direction of increasing values on the axes.

"ij" Reverse y-axis, so lower values are nearer the top.

"xy" Restore y-axis, so higher values are nearer the top.

17.2 Specialized Two-Dimensional Plots

bar (*x*, *y*) Function File

Given two vectors of x-y data, **bar** produces a bar graph.

If only one argument is given, it is taken as a vector of y-values and the x coordinates are taken to be the indices of the elements.

If two output arguments are specified, the data are generated but not plotted. For example,

```
bar (x, y);
```

and

```
[xb, yb] = bar (x, y);
plot (xb, yb);
```

are equivalent.

- contour** (*z*, *n*) Function File
contour (*x*, *y*, *z*, *n*) Function File
 Make a contour plot of the three-dimensional surface described by *z*. Someone needs to improve **gnuplot**'s contour routines before this will be very useful.
- hist** (*y*, *x*, *norm*) Function File
 Produce histogram counts or plots.
 With one vector input argument, plot a histogram of the values with 10 bins. The range of the histogram bins is determined by the range of the data.
 Given a second scalar argument, use that as the number of bins.
 Given a second vector argument, use that as the centers of the bins, with the width of the bins determined from the adjacent values in the vector.
 If third argument is provided, the histogram is normalised such that the sum of the bars is equal to *norm*.
 Extreme values are lumped in the first and last bins.
 With two output arguments, produce the values *nn* and *xx* such that **bar** (*xx*, *nn*) will plot the histogram.
- loglog** (*args*) Function File
 Make a two-dimensional plot using log scales for both axes. See the description of **plot** for a description of the arguments that **loglog** will accept.
- polar** (*theta*, *rho*, *fmt*) Function File
 Make a two-dimensional plot given polar the coordinates *theta* and *rho*.
 The optional third argument specifies the line type.
- semilogx** (*args*) Function File
 Make a two-dimensional plot using a log scale for the x axis. See the description of **plot** for a description of the arguments that **semilogx** will accept.
- semilogy** (*args*) Function File
 Make a two-dimensional plot using a log scale for the y axis. See the description of **plot** for a description of the arguments that **semilogy** will accept.
- stairs** (*x*, *y*) Function File
 Given two vectors of x-y data, **stairs** produces a 'stairstep' plot.
 If only one argument is given, it is taken as a vector of y-values and the x coordinates are taken to be the indices of the elements.
 If two output arguments are specified, the data are generated but not plotted. For example,

```
stairs (x, y);
```

 and

```
[xs, ys] = stairs (x, y);
plot (xs, ys);
```

are equivalent.

errorbar (*args*)

Function File

This function produces two-dimensional plots with errorbars. Many different combinations of arguments are possible. The simplest form is

```
errorbar (y, ey)
```

where the first argument is taken as the set of y coordinates and the second argument ey is taken as the errors of the y values. x coordinates are taken to be the indices of the elements, starting with 1.

If more than two arguments are given, they are interpreted as

```
errorbar (x, y, ..., fmt ...)
```

where after x and y there can be up to four error parameters such as ey , ex , ly , uy etc., depending on the plot type. Any number of argument sets may appear, as long as they are separated with a format string fmt .

If y is a matrix, x and error parameters must also be matrices having same dimensions. The columns of y are plotted versus the corresponding columns of x and errorbars are drawn from the corresponding columns of error parameters.

If fmt is missing, yerrorbars (" \sim ") plot style is assumed. If the fmt argument is supplied, it is interpreted as in normal plots (See `_pltopt_`). In addition the following plot styles are supported by errorbar:

```
'~'      Set yerrorbars plot style (default).
'>'      Set xerrorbars plot style.
'~>'     Set xyerrorbars plot style.
'#'      Set boxes plot style.
'#~'     Set boxerrorbars plot style.
'#~>'    Set boxxyerrorbars plot style.
```

Examples:

```
errorbar(x, y, ex, ">")
```

xerrorbar plot of y versus x with x errorbars drawn from $x-ex$ to $x+ex$.

```
errorbar(x, y1, ey, "~", x, y2, ly, uy)
```

Two yerrorbar plots with $y1$ and $y2$ versus x . Errorbars for $y1$ are drawn from $y1-ey$ to $y1+ey$, errorbars for $y2$ from $y2-ly$ to $y2+uy$.

```
errorbar(x, y, lx, ux, ly, uy, "~>")
```

xyerrorbar plot of y versus x where x errorbars are drawn from $x-lx$ to $x+ux$ and y errorbars from $y-ly$ to $y+uy$.

loglogerr (*args*) Function File

This function produces two-dimensional plots on double logarithm axis with errorbars. Many different combinations of arguments are possible. The most used form is

```
loglogerr (x, y, ey, fmt)
```

which produces a double logarithm plot of *y* versus *x* with errors in the *y*-scale defined by *ey* and the plot format defined by *fmt*. See `errorbar` for available formats and additional information.

semilogxerr (*args*) Function File

This function produces two-dimensional plots on a semilogarithm axis with errorbars. Many different combinations of arguments are possible. The most used form is

```
semilogxerr (x, y, ey, fmt)
```

which produces a semi-logarithm plot of *y* versus *x* with errors in the *y*-scale defined by *ey* and the plot format defined by *fmt*. See `errorbar` for available formats and additional information.

semilogyerr (*args*) Function File

This function produces two-dimensional plots on a semilogarithm axis with errorbars. Many different combinations of arguments are possible. The most used form is

```
semilogyerr (x, y, ey, fmt)
```

which produces a semi-logarithm plot of *y* versus *x* with errors in the *y*-scale defined by *ey* and the plot format defined by *fmt*. See `errorbar` for available formats and additional information.

17.3 Three-Dimensional Plotting

gsplot *ranges expression using title style* Command

Generate a 3-dimensional plot.

The *ranges*, *using*, *title*, and *style* arguments are optional, and the *using*, *title* and *style* qualifiers may appear in any order after the expression. You may plot multiple expressions with a single command by separating them with commas. Each expression may have its own set of qualifiers.

The optional item *ranges* has the syntax

```
[ x_lo : x_up ] [ y_lo : y_up ] [ z_lo : z_up ]
```

and may be used to specify the ranges for the axes of the plot, independent of the actual range of the data. The range for the *y* and *z* axes and any of the individual limits may be omitted. A range `[:]` indicates that the default limits should be used. This normally means that a range just large enough to include all the data points will be used.

The expression to be plotted must not contain any literal matrices (e.g. `[1, 2; 3, 4]`) since it is nearly impossible to distinguish a plot range from a matrix of data.

See the help for `gnuplot` for a description of the syntax for the optional items.

By default, the `gsplot` command plots each column of the expression as the z value, using the row index as the x value, and the column index as the y value. The indices are counted from zero, not one. For example,

```
gsplot rand (5, 2)
```

will plot a random surface, with the x and y values taken from the row and column indices of the matrix.

If parametric plotting mode is set (using the command `gset parametric`, then `gsplot` takes the columns of the matrix three at a time as the x , y and z values that define a line in three space. Any extra columns are ignored, and the x and y values are expected to be sorted. For example, with `parametric` set, it makes sense to plot a matrix like

$$\begin{bmatrix} 1 & 1 & 3 & 2 & 1 & 6 & 3 & 1 & 9 \\ 1 & 2 & 2 & 2 & 2 & 5 & 3 & 2 & 8 \\ 1 & 3 & 1 & 2 & 3 & 4 & 3 & 3 & 7 \end{bmatrix}$$

but not `rand (5, 30)`.

The MATLAB-style three-dimensional plotting commands are:

mesh (x , y , z) Function File

Plot a mesh given matrices x , and y from `meshdom` and a matrix z corresponding to the x and y coordinates of the mesh. If x and y are vectors, then a typical vertex is $(x(j), y(i), z(i,j))$. Thus, columns of z correspond to different x values and rows of z correspond to different y values.

$[xx, yy] = \text{meshgrid} (x, y)$ Function File

$[xx, yy] = \text{meshgrid} (x)$ Function File

Given vectors of x and y coordinates, return two matrices corresponding to the x and y coordinates of a mesh. The rows of xx are copies of x , and the columns of yy are copies of y .

meshdom (x , y) Function File

Given vectors of x and y coordinates, return two matrices corresponding to the x and y coordinates of the mesh.

Note: this function is provided for compatibility with older versions of MATLAB. You should use `meshgrid` instead.

17.4 Plot Annotations

grid (arg) Function File

For two-dimensional plotting, force the display of a grid on the plot. The argument may be either "on" or "off". If it is omitted, "on" is assumed.

title ($string$) Function File

Specify a title for a plot. If you already have a plot displayed, use the command `replot` to redisplay it with the new title.

bottom_title (*string*) Function File
See top_title.

xlabel (*string*) Function File

ylabel (*string*) Function File

zlabel (*string*) Function File

Specify x, y, and z axis labels for the plot. If you already have a plot displayed, use the command `replot` to redisplay it with the new labels.

17.5 Multiple Plots on One Page

The following functions all require a version of `gnuplot` that supports the multiplot feature.

mplot (*x, y*) Function File

mplot (*x, y, fmt*) Function File

mplot (*x1, y1, x2, y2*) Function File

This is a modified version of the `plot` function that works with the multiplot version of `gnuplot` to plot multiple plots per page. This plot version automatically advances to the next subplot position after each set of arguments are processed.

See the description of the `plot` function for the various options.

multiplot (*xn, yn*) Function File

Sets and resets multiplot mode.

If the arguments are non-zero, `multiplot` will set up multiplot mode with *xn*, *yn* subplots along the x and y axes. If both arguments are zero, `multiplot` closes multiplot mode.

oneplot () Function File

If in multiplot mode, switches to single plot mode.

plot_border (...) Function File

Multiple arguments allowed to specify the sides on which the border is shown. Allowed arguments include:

"blank" No borders displayed.

"all" All borders displayed

"north" North Border

"south" South Border

"east" East Border

"west" West Border

The arguments may be abbreviated to single characters. Without any arguments, `plot_border` turns borders off.

subplot (*rows, cols, index*) Function File

subplot (*rcn*) Function File

Sets `gnuplot` in multiplot mode and plots in location given by index (there are *cols* by *rows* subwindows).

The global variable `__multiplot_scale__` should be used when the command `gset size xsize, ysize` has been used prior to calling `subplot`.

The value of `__multiplot_scale__` should be a vector with two elements, the first set equal to *xsize* and the second to *ysize*.

Input:

rows Number of rows in subplot grid.

columns Number of columns in subplot grid.

index Index of subplot where to make the next plot.

If only one argument is supplied, then it must be a three digit value specifying the location in digits 1 (rows) and 2 (columns) and the plot index in digit 3.

The plot index runs row-wise. First all the columns in a row are filled and then the next row is filled.

For example, a plot with 4 by 2 grid will have plot indices running as follows:

1	2	3	4
5	6	7	8

subwindow (*xn, yn*) Function File

Sets the subwindow position in multiplot mode for the next plot. The multiplot mode has to be previously initialized using the `multiplot` function, otherwise this command just becomes an alias to `multiplot`

top_title (*string*) Function File

bottom_title (*string*) Function File

Makes a title with text *string* at the top (bottom) of the plot.

17.6 Multiple Plot Windows

figure (*n*) Function File

Set the current plot window to plot window *n*. This function currently requires X11 and a version of `gnuplot` that supports multiple frames. If *n* is not specified, the next available window number is chosen.

17.7 Interaction with gnuplot

gnuplot_binary	Built-in Variable
The name of the program invoked by the plot command. The default value is "gnuplot". See Appendix C [Installation], page 329.	
gnuplot_has_frames	Built-in Variable
If the value of this variable is nonzero, Octave assumes that your copy of gnuplot has support for multiple frames that is included in recent 3.6beta releases. Its initial value is determined by configure, but it can be changed in your startup script or at the command line in case configure got it wrong, or if you upgrade your gnuplot installation.	
graw (<i>string</i>)	Built-in Function
Send <i>string</i> directly to gnuplot subprocess.	
gnuplot_command_plot	Built-in Variable
gnuplot_command_replot	Built-in Variable
gnuplot_command_splot	Built-in Variable
gnuplot_command_using	Built-in Variable
gnuplot_command_with	Built-in Variable
gnuplot_command_axes	Built-in Variable
gnuplot_command_title	Built-in Variable
gnuplot_command_end	Built-in Variable

18 Matrix Manipulation

There are a number of functions available for checking to see if the elements of a matrix meet some condition, and for rearranging the elements of a matrix. For example, Octave can easily tell you if all the elements of a matrix are finite, or are less than some specified value. Octave can also rotate the elements, extract the upper- or lower-triangular parts, or sort the columns of a matrix.

18.1 Finding Elements and Checking Conditions

The functions `any` and `all` are useful for determining whether any or all of the elements of a matrix satisfy some condition. The `find` function is also useful in determining which elements of a matrix meet a specified condition.

any (*x*, *dim*) Built-in Function

For a vector argument, return 1 if any element of the vector is nonzero.

For a matrix argument, return a row vector of ones and zeros with each element indicating whether any of the elements of the corresponding column of the matrix are nonzero. For example,

```
any (eye (2, 4))
⇒ [ 1, 1, 0, 0 ]
```

If the optional argument *dim* is supplied, work along dimension *dim*. For example,

```
any (eye (2, 4), 2)
⇒ [ 1; 1 ]
```

all (*x*, *dim*) Built-in Function

The function `all` behaves like the function `any`, except that it returns true only if all the elements of a vector, or all the elements along dimension *dim* of a matrix, are nonzero.

Since the comparison operators (see Section 10.4 [Comparison Ops], page 70) return matrices of ones and zeros, it is easy to test a matrix for many things, not just whether the elements are nonzero. For example,

```
all (all (rand (5) < 0.9))
⇒ 0
```

tests a random 5 by 5 matrix to see if all of its elements are less than 0.9.

Note that in conditional contexts (like the test clause of `if` and `while` statements) Octave treats the test as if you had typed `all (all (condition))`.

xor (*x*, *y*) Mapping Function

Return the ‘exclusive or’ of the entries of *x* and *y*. For boolean expressions *x* and *y*, `xor (x, y)` is true if and only if *x* or *y* is true, but not if both *x* and *y* are true.

is_duplicate_entry (*x*) Function File

Return non-zero if any entries in *x* are duplicates of one another.

diff (*x*, *k*, *dim*) Function File

If *x* is a vector of length *n*, **diff** (*x*) is the vector of first differences $x_2 - x_1, \dots, x_n - x_{n-1}$.

If *x* is a matrix, **diff** (*x*) is the matrix of column differences along the first non-singleton dimension.

The second argument is optional. If supplied, **diff** (*x*, *k*), where *k* is a nonnegative integer, returns the *k*-th differences. It is possible that *k* is larger than the first non-singleton dimension of the matrix. In this case, **diff** continues to take the differences along the next non-singleton dimension.

The dimension along which to take the difference can be explicitly stated with the optional variable *dim*. In this case the *k*-th order differences are calculated along this dimension. In the case where *k* exceeds **size** (*x*, *dim*) then an empty matrix is returned.

isinf (*x*) Mapping Function

Return 1 for elements of *x* that are infinite and zero otherwise. For example,

```
isinf ([13, Inf, NA, NaN])
⇒ [ 0, 1, 0, 0 ]
```

isnan (*x*) Mapping Function

Return 1 for elements of *x* that are NaN values and zero otherwise. For example,

```
isnan ([13, Inf, NA, NaN])
⇒ [ 0, 0, 0, 1 ]
```

finite (*x*) Mapping Function

Return 1 for elements of *x* that are finite values and zero otherwise. For example,

```
finite ([13, Inf, NA, NaN])
⇒ [ 1, 0, 0, 0 ]
```

find (*x*) Loadable Function

Return a vector of indices of nonzero elements of a matrix. To obtain a single index for each matrix element, Octave pretends that the columns of a matrix form one long vector (like Fortran arrays are stored). For example,

```
find (eye (2))
⇒ [ 1; 4 ]
```

If two outputs are requested, **find** returns the row and column indices of nonzero elements of a matrix. For example,

```
[i, j] = find (2 * eye (2))
⇒ i = [ 1; 2 ]
⇒ j = [ 1; 2 ]
```

If three outputs are requested, **find** also returns a vector containing the nonzero values. For example,

```
[i, j, v] = find (3 * eye (2))
⇒ i = [ 1; 2 ]
⇒ j = [ 1; 2 ]
⇒ v = [ 3; 3 ]
```

[err, y1, ...] = common_size (x1, ...) Function File

Determine if all input arguments are either scalar or of common size. If so, *err* is zero, and *yi* is a matrix of the common size with all entries equal to *xi* if this is a scalar or *xi* otherwise. If the inputs cannot be brought to a common size, errorcode is 1, and *yi* is *xi*. For example,

```
[errorcode, a, b] = common_size ([1 2; 3 4], 5)
⇒ errorcode = 0
⇒ a = [ 1, 2; 3, 4 ]
⇒ b = [ 5, 5; 5, 5 ]
```

This is useful for implementing functions where arguments can either be scalars or of common size.

18.2 Rearranging Matrices

fliplr (x) Function File

Return a copy of *x* with the order of the columns reversed. For example,

```
fliplr ([1, 2; 3, 4])
⇒ 2 1
   4 3
```

Due to the difficulty of defining which axis about which to flip the matrix `fliplr` only work with 2-D arrays. To flip N-D arrays use `flipdim` instead.

flipud (x) Function File

Return a copy of *x* with the order of the rows reversed. For example,

```
flipud ([1, 2; 3, 4])
⇒ 3 4
   1 2
```

Due to the difficulty of defining which axis about which to flip the matrix `flipud` only work with 2-d arrays. To flip N-d arrays use `flipdim` instead.

flipdim (x, dim) Function File

Return a copy of *x* flipped about the dimension *dim*. For example

```
flipdim ([1, 2; 3, 4], 2)
⇒ 2 1
   4 3
```

rot90 (*x*, *n*) Function File

Return a copy of *x* with the elements rotated counterclockwise in 90-degree increments. The second argument is optional, and specifies how many 90-degree rotations are to be applied (the default value is 1). Negative values of *n* rotate the matrix in a clockwise direction. For example,

```
rot90 ([1, 2; 3, 4], -1)
⇒  3  1
    4  2
```

rotates the given matrix clockwise by 90 degrees. The following are all equivalent statements:

```
rot90 ([1, 2; 3, 4], -1)
≡
rot90 ([1, 2; 3, 4], 3)
≡
rot90 ([1, 2; 3, 4], 7)
```

Due to the difficulty of defining an axis about which to rotate the matrix `rot90` only work with 2-D arrays. To rotate N-d arrays use `rotdim` instead.

rotdim (*x*, *n*, *plane*) Function File

Return a copy of *x* with the elements rotated counterclockwise in 90-degree increments. The second argument is optional, and specifies how many 90-degree rotations are to be applied (the default value is 1). The third argument is also optional and defines the plane of the rotation. As such *plane* is a two element vector containing two different valid dimensions of the matrix. If *plane* is not given Then the first two non-singleton dimensions are used.

Negative values of *n* rotate the matrix in a clockwise direction. For example,

```
rotdim ([1, 2; 3, 4], -1, [1, 2])
⇒  3  1
    4  2
```

rotates the given matrix clockwise by 90 degrees. The following are all equivalent statements:

```
rot90 ([1, 2; 3, 4], -1, [1, 2])
≡
rot90 ([1, 2; 3, 4], 3, [1, 2])
≡
rot90 ([1, 2; 3, 4], 7, [1, 2])
```

cat (*dim*, *array1*, *array2*, ..., *arrayN*) Built-in Function

Return the concatenation of N-d array objects, *array1*, *array2*, ..., *arrayN* along dimension *dim*.

```
A = ones (2, 2);
B = zeros (2, 2);
cat (2, A, B)
⇒ ans =
```

```
1 1 0 0
1 1 0 0
```

Alternatively, we can concatenate *A* and *B* along the second dimension the following way:

```
[A, B].
```

dim can be larger than the dimensions of the N-d array objects and the result will thus have *dim* dimensions as the following example shows:

```
cat (4, ones(2, 2), zeros (2, 2))
⇒ ans =
```

```
ans(:,:,1,1) =
```

```
1 1
1 1
```

```
ans(:,:,1,2) =
```

```
0 0
0 0
```

horzcat (*array1*, *array2*, ..., *arrayN*) Built-in Function

Return the horizontal concatenation of N-d array objects, *array1*, *array2*, ..., *arrayN* along dimension 2.

vertcat (*array1*, *array2*, ..., *arrayN*) Built-in Function

Return the vertical concatenation of N-d array objects, *array1*, *array2*, ..., *arrayN* along dimension 1.

permute (*a*, *perm*) Built-in Function

Return the generalized transpose for an N-d array object *a*. The permutation vector *perm* must contain the elements `1:ndims(a)` (in any order, but each element must appear just once).

ipermute (*a*, *iperm*) Built-in Function

The inverse of the `permute` function. The expression

```
ipermute (permute (a, perm), perm)
```

returns the original array *a*.

reshape (*a*, *m*, *n*, ...) Function File
reshape (*a*, *siz*) Function File

Return a matrix with the given dimensions whose elements are taken from the matrix *a*. The elements of the matrix are access in column-major order (like Fortran arrays are stored).

For example,

```
reshape ([1, 2, 3, 4], 2, 2)
⇒  1  3
   2  4
```

Note that the total number of elements in the original matrix must match the total number of elements in the new matrix.

A single dimension of the return matrix can be unknown and is flagged by an empty argument.

y = **circshift** (*x*, *n*) Function File

Circularly shifts the values of the array *x*. *n* must be a vector of integers no longer than the number of dimensions in *x*. The values of *n* can be either positive or negative, which determines the direction in which the values or *x* are shifted. If an element of *n* is zero, then the corresponding dimension of *x* will not be shifted. For example

```
x = [1, 2, 3; 4, 5, 6, 7, 8, 9];
circshift (x, 1)
⇒  7, 8, 9
   1, 2, 3
   4, 5, 6
circshift (x, -2)
⇒  7, 8, 9
   1, 2, 3
   4, 5, 6
circshift (x, [0,1])
⇒  3, 1, 2
   6, 4, 5
   9, 7, 8
```

y = **shiftdim** (*x*, *n*) Function File
[*y*, *ns*] = **shiftdim** (*x*) Function File

Shifts the dimension of *x* by *n*, where *n* must be an integer scalar. When *n* is negative, the dimensions of *x* are shifted to the left, with the leading dimensions circulated to the end. If *n* is positive, then the dimensions of *x* are shifted to the right, with the *n* singleton dimensions added.

Called with a single argument, **shiftdim**, removes the leading singleton dimensions, returning the number of dimensions removed in the second output argument *ns*.

For example

```

x = ones (1, 2, 3);
size (shiftdim (x, -1))
⇒ [2, 3, 1]
size (shiftdim (x, 1))
⇒ [1, 1, 2, 3]
[b, ns] = shiftdim (x);
⇒ b = [1, 1, 1; 1, 1, 1]
⇒ ns = 1

```

shift (*x*, *b*) Function File
shift (*x*, *b*, *dim*) Function File

If *x* is a vector, perform a circular shift of length *b* of the elements of *x*.

If *x* is a matrix, do the same for each column of *x*. If the optional *dim* argument is given, operate along this dimension

[*s*, *i*] = **sort** (*x*) Loadable Function
 [*s*, *i*] = **sort** (*x*, *dim*) Loadable Function
 [*s*, *i*] = **sort** (*x*, *mode*) Loadable Function
 [*s*, *i*] = **sort** (*x*, *dim*, *mode*) Loadable Function

Return a copy of *x* with the elements arranged in increasing order. For matrices, **sort** orders the elements in each column.

For example,

```

sort ([1, 2; 2, 3; 3, 1])
⇒ 1 1
   2 2
   3 3

```

The **sort** function may also be used to produce a matrix containing the original row indices of the elements in the sorted matrix. For example,

```

[s, i] = sort ([1, 2; 2, 3; 3, 1])
⇒ s = 1 1
     2 2
     3 3
⇒ i = 1 3
     2 1
     3 2

```

If the optional argument *dim* is given, then the matrix is sorted along the dimension defined by *dim*. The optional argument *mode* defines the order in which the values will be sorted. Valid values of *mode* are ‘ascend’ or ‘descend’.

For equal elements, the indices are such that the equal elements are listed in the order that appeared in the original list.

The **sort** function may also be used to sort strings and cell arrays of strings, in which case the dictionary order of the strings is used.

The algorithm used in **sort** is optimized for the sorting of partially ordered lists.

Since the `sort` function does not allow sort keys to be specified, it can't be used to order the rows of a matrix according to the values of the elements in various columns¹ in a single call. Using the second output, however, it is possible to sort all rows based on the values in a given column. Here's an example that sorts the rows of a matrix based on the values in the second column.

```
a = [1, 2; 2, 3; 3, 1];
[s, i] = sort (a (:, 2));
a (i, :)
⇒ 3 1
   1 2
   2 3
```

tril (*a*, *k*) Function File
triu (*a*, *k*) Function File

Return a new matrix formed by extracting extract the lower (**tril**) or upper (**triu**) triangular part of the matrix *a*, and setting all other elements to zero. The second argument is optional, and specifies how many diagonals above or below the main diagonal should also be set to zero.

The default value of *k* is zero, so that **triu** and **tril** normally include the main diagonal as part of the result matrix.

If the value of *k* is negative, additional elements above (for **tril**) or below (for **triu**) the main diagonal are also selected.

The absolute value of *k* must not be greater than the number of sub- or super-diagonals.

For example,

```
tril (ones (3), -1)
⇒ 0 0 0
   1 0 0
   1 1 0
```

and

```
tril (ones (3), 1)
⇒ 1 1 0
   1 1 1
   1 1 1
```

vec (*x*) Function File
Return the vector obtained by stacking the columns of the matrix *x* one above the other.

vech (*x*) Function File
Return the vector obtained by eliminating all supradiagonal elements of the square matrix *x* and stacking the result one column above the other.

¹ For example, to first sort based on the values in column 1, and then, for any values that are repeated in column 1, sort based on the values found in column 2, etc.

prepad (x, l, c) Function File
postpad (x, l, c) Function File
postpad (x, l, c, dim) Function File

Prepends (appends) the scalar value c to the vector x until it is of length l . If the third argument is not supplied, a value of 0 is used.

If `length(x) > l`, elements from the beginning (end) of x are removed until a vector of length l is obtained.

If x is a matrix, elements are prepended or removed from each row.

If the optional *dim* argument is given, then operate along this dimension.

18.3 Special Utility Matrices

eye (x) Built-in Function
eye (n, m) Built-in Function
eye ($\dots, class$) Built-in Function

Return an identity matrix. If invoked with a single scalar argument, `eye` returns a square matrix with the dimension specified. If you supply two scalar arguments, `eye` takes them to be the number of rows and columns. If given a vector with two elements, `eye` uses the values of the elements as the number of rows and columns, respectively. For example,

```
eye (3)
⇒  1  0  0
    0  1  0
    0  0  1
```

The following expressions all produce the same result:

```
eye (2)
≡
eye (2, 2)
≡
eye (size ([1, 2; 3, 4])
```

The optional argument *class*, allows `eye` to return an array of the specified type, like

```
val = zeros (n,m, "uint8")
```

For compatibility with MATLAB, calling `eye` with no arguments is equivalent to calling it with an argument of 1.

ones (x) Built-in Function
ones (n, m) Built-in Function
ones (n, m, k, \dots) Built-in Function
ones ($\dots, class$) Built-in Function

Return a matrix or N-dimensional array whose elements are all 1. The arguments are handled the same as the arguments for `eye`.

If you need to create a matrix whose values are all the same, you should use an expression like

```
val_matrix = val * ones (n, m)
```

The optional argument *class*, allows **ones** to return an array of the specified type, like

```
val = ones (n,m, "uint8")
```

zeros (<i>x</i>)	Built-in Function
zeros (<i>n</i> , <i>m</i>)	Built-in Function
zeros (<i>n</i> , <i>m</i> , <i>k</i> , ...)	Built-in Function
zeros (... , <i>class</i>)	Built-in Function

Return a matrix or N-dimensional array whose elements are all 0. The arguments are handled the same as the arguments for **eye**.

The optional argument *class*, allows **zeros** to return an array of the specified type, like

```
val = zeros (n,m, "uint8")
```

repmat (<i>A</i> , <i>m</i> , <i>n</i>)	Function File
repmat (<i>A</i> , [<i>m</i> <i>n</i>])	Function File

Form a block matrix of size *m* by *n*, with a copy of matrix *A* as each element. If *n* is not specified, form an *m* by *m* block matrix.

rand (<i>x</i>)	Loadable Function
rand (<i>n</i> , <i>m</i>)	Loadable Function
rand ("seed", <i>x</i>)	Loadable Function

Return a matrix with random elements uniformly distributed on the interval (0, 1).

The arguments are handled the same as the arguments for **eye**. In addition, you can set the seed for the random number generator using the form

```
rand ("seed", x)
```

where *x* is a scalar value. If called as

```
rand ("seed")
```

rand returns the current value of the seed.

randn (<i>x</i>)	Loadable Function
randn (<i>n</i> , <i>m</i>)	Loadable Function
randn ("seed", <i>x</i>)	Loadable Function

Return a matrix with normally distributed random elements. The arguments are handled the same as the arguments for **eye**. In addition, you can set the seed for the random number generator using the form

```
randn ("seed", x)
```

where *x* is a scalar value. If called as

```
randn ("seed")
```

randn returns the current value of the seed.

The `rand` and `randn` functions use separate generators. This ensures that

```
rand ("seed", 13);
randn ("seed", 13);
u = rand (100, 1);
n = randn (100, 1);
```

and

```
rand ("seed", 13);
randn ("seed", 13);
u = zeros (100, 1);
n = zeros (100, 1);
for i = 1:100
    u(i) = rand ();
    n(i) = randn ();
end
```

produce equivalent results.

Normally, `rand` and `randn` obtain their initial seeds from the system clock, so that the sequence of random numbers is not the same each time you run Octave. If you really do need for to reproduce a sequence of numbers exactly, you can set the seed to a specific value.

If it is invoked without arguments, `rand` and `randn` return a single element of a random sequence.

The `rand` and `randn` functions use Fortran code from RANLIB, a library of fortran routines for random number generation, compiled by Barry W. Brown and James Lovato of the Department of Biomathematics at The University of Texas, M.D. Anderson Cancer Center, Houston, TX 77030.

randperm (*n*)

Function File

Return a row vector containing a random permutation of the integers from 1 to *n*.

diag (*v*, *k*)

Built-in Function

Return a diagonal matrix with vector *v* on diagonal *k*. The second argument is optional. If it is positive, the vector is placed on the *k*-th super-diagonal. If it is negative, it is placed on the *-k*-th sub-diagonal. The default value of *k* is 0, and the vector is placed on the main diagonal. For example,

```
diag ([1, 2, 3], 1)
⇒  0  1  0  0
    0  0  2  0
    0  0  0  3
    0  0  0  0
```

The functions `linspace` and `logspace` make it very easy to create vectors with evenly or logarithmically spaced elements. See Section 4.2 [Ranges], page 37.

linspace (*base*, *limit*, *n*)

Built-in Function

Return a row vector with *n* linearly spaced elements between *base* and *limit*. The number of elements, *n*, must be greater than 1. The *base* and *limit* are always included

in the range. If *base* is greater than *limit*, the elements are stored in decreasing order. If the number of points is not specified, a value of 100 is used.

The `linspace` function always returns a row vector.

logspace (*base*, *limit*, *n*) Function File
 Similar to `linspace` except that the values are logarithmically spaced from 10^{base} to 10^{limit} .

If *limit* is equal to π , the points are between 10^{base} and π , *not* 10^{base} and 10^π , in order to be compatible with the corresponding MATLAB function.

warn_neg_dim_as_zero Built-in Variable
 If the value of `warn_neg_dim_as_zero` is nonzero, print a warning for expressions like
`eye (-1)`

The default value is 0.

warn_imag_to_real Built-in Variable
 If the value of `warn_imag_to_real` is nonzero, a warning is printed for implicit conversions of complex numbers to real numbers. The default value is 0.

18.4 Famous Matrices

The following functions return famous matrix forms.

hankel (*c*, *r*) Function File
 Return the Hankel matrix constructed given the first column *c*, and (optionally) the last row *r*. If the last element of *c* is not the same as the first element of *r*, the last element of *c* is used. If the second argument is omitted, it is assumed to be a vector of zeros with the same size as *c*.

A Hankel matrix formed from an *m*-vector *c*, and an *n*-vector *r*, has the elements

$$H(i, j) = \begin{cases} c_{i+j-1}, & i + j - 1 \leq m; \\ r_{i+j-m}, & \text{otherwise.} \end{cases}$$

hilb (*n*) Function File
 Return the Hilbert matrix of order *n*. The *i*, *j* element of a Hilbert matrix is defined as

$$H(i, j) = \frac{1}{(i + j - 1)}$$

invhilb (*n*)

Function File

Return the inverse of a Hilbert matrix of order n . This can be computed exactly using

$$A_{ij} = -1^{i+j}(i+j-1) \binom{n+i-1}{n-j} \binom{n+j-1}{n-i} \binom{i+j-2}{i-2}^2$$

$$= \frac{p(i)p(j)}{(i+j-1)}$$

where

$$p(k) = -1^k \binom{k+n-1}{k-1} \binom{n}{k}$$

The validity of this formula can easily be checked by expanding the binomial coefficients in both formulas as factorials. It can be derived more directly via the theory of Cauchy matrices: see J. W. Demmel, *Applied Numerical Linear Algebra*, page 92.

Compare this with the numerical calculation of `inverse(hilb(n))`, which suffers from the ill-conditioning of the Hilbert matrix, and the finite precision of your computer's floating point arithmetic.

sylvester_matrix (*k*)

Function File

Return the Sylvester matrix of order $n = 2^k$.

toeplitz (*c*, *r*)

Function File

Return the Toeplitz matrix constructed given the first column c , and (optionally) the first row r . If the first element of c is not the same as the first element of r , the first element of c is used. If the second argument is omitted, the first row is taken to be the same as the first column.

A square Toeplitz matrix has the form:

$$\begin{bmatrix} c_0 & r_1 & r_2 & \cdots & r_n \\ c_1 & c_0 & r_1 & \cdots & r_{n-1} \\ c_2 & c_1 & c_0 & \cdots & r_{n-2} \\ \vdots & \vdots & \vdots & \ddots & \vdots \\ c_n & c_{n-1} & c_{n-2} & \cdots & c_0 \end{bmatrix}$$

vander (*c*)

Function File

Return the Vandermonde matrix whose next to last column is c .

A Vandermonde matrix has the form:

$$\begin{bmatrix} c_1^{n-1} & \cdots & c_1^2 & c_1 & 1 \\ c_2^{n-1} & \cdots & c_2^2 & c_2 & 1 \\ \vdots & \ddots & \vdots & \vdots & \vdots \\ c_n^{n-1} & \cdots & c_n^2 & c_n & 1 \end{bmatrix}$$

19 Arithmetic

Unless otherwise noted, all of the functions described in this chapter will work for real and complex scalar or matrix arguments.

19.1 Utility Functions

The following functions are available for working with complex numbers. Each expects a single argument. They are called *mapping functions* because when given a matrix argument, they apply the given function to each element of the matrix.

ceil (x) Mapping Function
 Return the smallest integer not less than x . If x is complex, return `ceil (real (x)) + ceil (imag (x)) * I`.

exp (x) Mapping Function
 Compute the exponential of x . To compute the matrix exponential, see Chapter 20 [Linear Algebra], page 173.

fix (x) Mapping Function
 Truncate x toward zero. If x is complex, return `fix (real (x)) + fix (imag (x)) * I`.

floor (x) Mapping Function
 Return the largest integer not greater than x . If x is complex, return `floor (real (x)) + floor (imag (x)) * I`.

$g = \mathbf{gcd} (a1, \dots)$ Loadable Function
 $[g, v1, \dots] = \mathbf{gcd} (a1, \dots)$ Loadable Function

If a single argument is given then compute the greatest common divisor of the elements of this argument. Otherwise if more than one argument is given all arguments must be the same size or scalar. In this case the greatest common divisor is calculated for element individually. All elements must be integers. For example,

$$\begin{aligned} \mathbf{gcd} ([15, 20]) \\ \Rightarrow 5 \end{aligned}$$

and

$$\begin{aligned} \mathbf{gcd} ([15, 9], [20, 18]) \\ \Rightarrow 5 \quad 9 \end{aligned}$$

Optional return arguments $v1$, etc, contain integer vectors such that,

$$g = v_1 a_1 + v_2 a_2 + \dots$$

For backward compatibility with previous versions of this function, when all arguments are scalar, a single return argument $v1$ containing all of the values of $v1, \dots$ is acceptable.

lcm (x, \dots) Mapping Function
 Compute the least common multiple of the elements of x , or the list of all the arguments. For example,

$$\text{lcm} (a_1, \dots, a_k)$$

is the same as

$$\text{lcm} ([a_1, \dots, a_k]).$$

All elements must be the same size or scalar.

log (x) Mapping Function
 Compute the natural logarithm for each element of x . To compute the matrix logarithm, see Chapter 20 [Linear Algebra], page 173.

log10 (x) Mapping Function
 Compute the base-10 logarithm for each element of x .

log2 (x) Mapping Function
 $[f, e] = \text{log2} (x)$ Mapping Function
 Compute the base-2 logarithm of x . With two outputs, returns f and e such that $1/2 \leq |f| < 1$ and $x = f \cdot 2^e$.

max (x, y, dim) Mapping Function
 $[w, iw] = \text{max} (x)$ Mapping Function
 For a vector argument, return the maximum value. For a matrix argument, return the maximum value from each column, as a row vector, or over the dimension dim if defined. For two matrices (or a matrix and scalar), return the pair-wise maximum. Thus,

$$\text{max} (\text{max} (x))$$

returns the largest element of x , and

$$\begin{aligned} \text{max} (2:5, \text{pi}) \\ \Rightarrow 3.1416 \quad 3.1416 \quad 4.0000 \quad 5.0000 \end{aligned}$$

compares each element of the range 2:5 with pi , and returns a row vector of the maximum values.

For complex arguments, the magnitude of the elements are used for comparison.

If called with one input and two output arguments, **max** also returns the first index of the maximum value(s). Thus,

$$\begin{aligned} [x, ix] &= \text{max} ([1, 3, 5, 2, 5]) \\ \Rightarrow x &= 5 \\ ix &= 3 \end{aligned}$$

min (*x*, *y*, *dim*) Mapping Function
 [*w*, *iw*] = **min** (*x*) Mapping Function

For a vector argument, return the minimum value. For a matrix argument, return the minimum value from each column, as a row vector, or over the dimension *dim* if defined. For two matrices (or a matrix and scalar), return the pair-wise minimum. Thus,

```
min (min (x))
```

returns the smallest element of *x*, and

```
min (2:5, pi)
⇒ 2.0000 3.0000 3.1416 3.1416
```

compares each element of the range 2:5 with *pi*, and returns a row vector of the minimum values.

For complex arguments, the magnitude of the elements are used for comparison.

If called with one input and two output arguments, **min** also returns the first index of the minimum value(s). Thus,

```
[x, ix] = min ([1, 3, 0, 2, 5])
⇒ x = 0
   ix = 3
```

mod (*x*, *y*) Mapping Function

Compute modulo function, using

```
x - y .* floor (x ./ y)
```

Note that this handles negative numbers correctly: **mod** (-1, 3) is 2, not -1 as **rem** (-1, 3) returns. Also, **mod** (*x*, 0) returns *x*.

An error message is printed if the dimensions of the arguments do not agree, or if either of the arguments is complex.

nextpow2 (*x*) Function File

If *x* is a scalar, returns the first integer *n* such that $2^n \geq |x|$.

If *x* is a vector, return **nextpow2** (**length** (*x*)).

pow2 (*x*) Mapping Function

pow2 (*f*, *e*) Mapping Function

With one argument, computes 2^x for each element of *x*. With two arguments, returns $f \cdot 2^e$.

rem (*x*, *y*) Mapping Function

Return the remainder of *x* / *y*, computed using the expression

```
x - y .* fix (x ./ y)
```

An error message is printed if the dimensions of the arguments do not agree, or if either of the arguments is complex.

round (x) Mapping Function
 Return the integer nearest to x . If x is complex, return `round (real (x)) + round (imag (x)) * I`.

sign (x) Mapping Function
 Compute the *signum* function, which is defined as

$$\text{sign}(x) = \begin{cases} 1, & x > 0; \\ 0, & x = 0; \\ -1, & x < 0. \end{cases}$$

For complex arguments, `sign` returns `x ./ abs (x)`.

sqrt (x) Mapping Function
 Compute the square root of x . If x is negative, a complex result is returned. To compute the matrix square root, see Chapter 20 [Linear Algebra], page 173.

19.2 Complex Arithmetic

The following functions are available for working with complex numbers. Each expects a single argument. Given a matrix they work on an element by element basis. In the descriptions of the following functions, z is the complex number $x + iy$, where i is defined as $\sqrt{-1}$.

abs (z) Mapping Function
 Compute the magnitude of z , defined as $|z| = \sqrt{x^2 + y^2}$.

For example,

$$\begin{aligned} \text{abs} (3 + 4i) \\ \Rightarrow 5 \end{aligned}$$

arg (z) Mapping Function

angle (z) Mapping Function

Compute the argument of z , defined as $\theta = \tan^{-1}(y/x)$. in radians.

For example,

$$\begin{aligned} \text{arg} (3 + 4i) \\ \Rightarrow 0.92730 \end{aligned}$$

conj (z) Mapping Function

Return the complex conjugate of z , defined as $\bar{z} = x - iy$.

imag (z) Mapping Function

Return the imaginary part of z as a real number.

real (z) Mapping Function

Return the real part of z .

19.3 Trigonometry

Octave provides the following trigonometric functions. Angles are specified in radians. To convert from degrees to radians multiply by $\pi/180$ (e.g. `sin (30 * pi/180)` returns the sine of 30 degrees).

sin (x)	Mapping Function
Compute the sine of each element of x .	
cos (x)	Mapping Function
Compute the cosine of each element of x .	
tan (z)	Mapping Function
Compute tangent of each element of x .	
sec (x)	Mapping Function
Compute the secant of each element of x .	
csc (x)	Mapping Function
Compute the cosecant of each element of x .	
cot (x)	Mapping Function
Compute the cotangent of each element of x .	
asin (x)	Mapping Function
Compute the inverse sine of each element of x .	
acos (x)	Mapping Function
Compute the inverse cosine of each element of x .	
atan (x)	Mapping Function
Compute the inverse tangent of each element of x .	
asec (x)	Mapping Function
Compute the inverse secant of each element of x .	
acsc (x)	Mapping Function
Compute the inverse cosecant of each element of x .	
acot (x)	Mapping Function
Compute the inverse cotangent of each element of x .	

sinh (x)	Mapping Function
Compute the inverse hyperbolic sine of each element of x .	
cosh (x)	Mapping Function
Compute the hyperbolic cosine of each element of x .	
tanh (x)	Mapping Function
Compute hyperbolic tangent of each element of x .	
sech (x)	Mapping Function
Compute the hyperbolic secant of each element of x .	
csch (x)	Mapping Function
Compute the hyperbolic cosecant of each element of x .	
coth (x)	Mapping Function
Compute the hyperbolic cotangent of each element of x .	
asinh (x)	Mapping Function
Compute the inverse hyperbolic sine of each element of x .	
acosh (x)	Mapping Function
Compute the inverse hyperbolic cosine of each element of x .	
atanh (x)	Mapping Function
Compute the inverse hyperbolic tangent of each element of x .	
asech (x)	Mapping Function
Compute the inverse hyperbolic secant of each element of x .	
acsch (x)	Mapping Function
Compute the inverse hyperbolic cosecant of each element of x .	
acoth (x)	Mapping Function
Compute the inverse hyperbolic cotangent of each element of x .	

Each of these functions expect a single argument. For matrix arguments, they work on an element by element basis. For example,

```
sin ([1, 2; 3, 4])
⇒ 0.84147  0.90930
   0.14112 -0.75680
```

atan2 (y, x)	Mapping Function
Compute $\text{atan}(y / x)$ for corresponding elements of y and x . The result is in range $-\pi$ to π .	

19.4 Sums and Products

sum (*x*, *dim*) Built-in Function
 Sum of elements along dimension *dim*. If *dim* is omitted, it defaults to 1 (column-wise sum).

prod (*x*, *dim*) Built-in Function
 Product of elements along dimension *dim*. If *dim* is omitted, it defaults to 1 (column-wise products).

cumsum (*x*, *dim*) Built-in Function
 Cumulative sum of elements along dimension *dim*. If *dim* is omitted, it defaults to 1 (column-wise cumulative sums).

cumprod (*x*, *dim*) Built-in Function
 Cumulative product of elements along dimension *dim*. If *dim* is omitted, it defaults to 1 (column-wise cumulative products).

sumsq (*x*, *dim*) Built-in Function
 Sum of squares of elements along dimension *dim*. If *dim* is omitted, it defaults to 1 (column-wise sum of squares).

This function is equivalent to computing

```
sum (x .* conj (x), dim)
```

but it uses less memory and avoids calling conj if *x* is real.

19.5 Special Functions

<code>[j, ierr] = besselj (alpha, x, opt)</code>	Loadable Function
<code>[y, ierr] = bessely (alpha, x, opt)</code>	Loadable Function
<code>[i, ierr] = besseli (alpha, x, opt)</code>	Loadable Function
<code>[k, ierr] =esselk (alpha, x, opt)</code>	Loadable Function
<code>[h, ierr] =esselh (alpha, k, x, opt)</code>	Loadable Function

Compute Bessel or Hankel functions of various kinds:

besselj Bessel functions of the first kind.

bessely Bessel functions of the second kind.

besseli Modified Bessel functions of the first kind.

esselk Modified Bessel functions of the second kind.

esselh Compute Hankel functions of the first ($k = 1$) or second ($k = 2$) kind.

If the argument *opt* is supplied, the result is scaled by the `exp (-I*x)` for $k = 1$ or `exp (I*x)` for $k = 2$.

If *alpha* is a scalar, the result is the same size as *x*. If *x* is a scalar, the result is the same size as *alpha*. If *alpha* is a row vector and *x* is a column vector, the result is a matrix with `length (x)` rows and `length (alpha)` columns. Otherwise, *alpha* and *x* must conform and the result will be the same size.

The value of *alpha* must be real. The value of *x* may be complex.

If requested, *ierr* contains the following status information and is the same size as the result.

0. Normal return.
1. Input error, return NaN.
2. Overflow, return Inf.
3. Loss of significance by argument reduction results in less than half of machine accuracy.
4. Complete loss of significance by argument reduction, return NaN.
5. Error—no computation, algorithm termination condition not met, return NaN.

`[a, ierr] = airy (k, z, opt)` Loadable Function

Compute Airy functions of the first and second kind, and their derivatives.

K	Function	Scale factor (if a third argument is supplied)
0	Ai (Z)	<code>exp ((2/3) * Z * sqrt (Z))</code>
1	dAi(Z)/dZ	<code>exp ((2/3) * Z * sqrt (Z))</code>
2	Bi (Z)	<code>exp (-abs (real ((2/3) * Z *sqrt (Z))))</code>
3	dBi(Z)/dZ	<code>exp (-abs (real ((2/3) * Z *sqrt (Z))))</code>

The function call `airy (z)` is equivalent to `airy (0, z)`.

The result is the same size as *z*.

If requested, *ierr* contains the following status information and is the same size as the result.

0. Normal return.
1. Input error, return NaN.
2. Overflow, return Inf.
3. Loss of significance by argument reduction results in less than half of machine accuracy.
4. Complete loss of significance by argument reduction, return NaN.
5. Error—no computation, algorithm termination condition not met, return NaN

beta (*a*, *b*) Mapping Function

Return the Beta function,

$$B(a, b) = \frac{\Gamma(a)\Gamma(b)}{\Gamma(a + b)}.$$

betainc (x, a, b) Mapping Function

Return the incomplete Beta function,

$$\beta(a, b, x) = B(a, b)^{-1} \int_0^x t^{(a-1)}(1-t)^{(b-1)} dt.$$

If x has more than one component, both a and b must be scalars. If x is a scalar, a and b must be of compatible dimensions.

bincoeff (n, k) Mapping Function

Return the binomial coefficient of n and k , defined as

$$\binom{n}{k} = \frac{n(n-1)(n-2)\cdots(n-k+1)}{k!}$$

For example,

$$\begin{aligned} &\text{bincoeff}(5, 2) \\ &\Rightarrow 10 \end{aligned}$$

erf (z) Mapping Function

Computes the error function,

$$\text{erf}(z) = \frac{2}{\sqrt{\pi}} \int_0^z e^{-t^2} dt$$

erfc (z) Mapping Function

Computes the complementary error function, $1 - \text{erf}(z)$.

erfinv (z) Mapping Function

Computes the inverse of the error function.

gamma (z) Mapping Function

Computes the Gamma function,

$$\Gamma(z) = \int_0^\infty t^{z-1} e^{-t} dt.$$

gammainc (x, a) Mapping Function

Computes the incomplete gamma function,

$$\gamma(x, a) = \frac{\int_0^x e^{-t} t^{a-1} dt}{\Gamma(a)}$$

If a is scalar, then **gammainc** (x, a) is returned for each element of x and vice versa.

If neither x nor a is scalar, the sizes of x and a must agree, and **gammainc** is applied element-by-element.

lgamma (*a*, *x*) Mapping Function
gammaln (*a*, *x*) Mapping Function

Return the natural logarithm of the gamma function.

cross (*x*, *y*, *dim*) Function File

Computes the vector cross product of the two 3-dimensional vectors *x* and *y*.

```
cross ([1,1,0], [0,1,1])
⇒ [ 1; -1; 1 ]
```

If *x* and *y* are matrices, the cross product is applied along the first dimension with 3 elements. The optional argument *dim* is used to force the cross product to be calculated along the dimension defined by *dim*.

commutation_matrix (*m*, *n*) Function File

Return the commutation matrix $K_{m,n}$ which is the unique $mn \times mn$ matrix such that $K_{m,n} \cdot \text{vec}(A) = \text{vec}(A^T)$ for all $m \times n$ matrices *A*.

If only one argument *m* is given, $K_{m,m}$ is returned.

See Magnus and Neudecker (1988), Matrix differential calculus with applications in statistics and econometrics.

duplication_matrix (*n*) Function File

Return the duplication matrix D_n which is the unique $n^2 \times n(n+1)/2$ matrix such that $D_n * \text{vech}(A) = \text{vec}(A)$ for all symmetric $n \times n$ matrices *A*.

See Magnus and Neudecker (1988), Matrix differential calculus with applications in statistics and econometrics.

19.6 Coordinate Transformations

$[theta, r] = \text{cart2pol}(x, y)$ Function File

$[theta, r, z] = \text{cart2pol}(x, y, z)$ Function File

Transform cartesian to polar or cylindrical coordinates. *x*, *y* (and *z*) must be of same shape. *theta* describes the angle relative to the *x* - axis. *r* is the distance to the *z* - axis (0, 0, *z*).

$[x, y] = \text{pol2cart}(theta, r)$ Function File

$[x, y, z] = \text{pol2cart}(theta, r, z)$ Function File

Transform polar or cylindrical to cartesian coordinates. *theta*, *r* (and *z*) must be of same shape. *theta* describes the angle relative to the *x* - axis. *r* is the distance to the *z* - axis (0, 0, *z*).

$[theta, phi, r] = \text{cart2sph}(x, y, z)$ Function File

Transform cartesian to spherical coordinates. *x*, *y* and *z* must be of same shape. *theta* describes the angle relative to the *x* - axis. *phi* is the angle relative to the *xy* - plane. *r* is the distance to the origin (0, 0, 0).

$[x, y, z] = \text{sph2cart}(\text{theta}, \text{phi}, r)$ Function File
 Transform spherical to cartesian coordinates. x , y and z must be of same shape. theta describes the angle relative to the x-axis. phi is the angle relative to the xy-plane. r is the distance to the origin (0, 0, 0).

19.7 Mathematical Constants

I Built-in Variable
J Built-in Variable
i Built-in Variable
j Built-in Variable

A pure imaginary number, defined as $\sqrt{-1}$. These built-in variables behave like functions so you can use the names for other purposes. If you use them as variables and assign values to them and then clear them, they once again assume their special predefined values See Section 9.3 [Status of Variables], page 57.

Inf Built-in Variable
inf Built-in Variable

Infinity. This is the result of an operation like $1/0$, or an operation that results in a floating point overflow.

NaN Built-in Variable
nan Built-in Variable

Not a number. This is the result of an operation like $0/0$, or $\infty - \infty$, or any operation with a NaN.

Note that NaN always compares not equal to NaN. This behavior is specified by the IEEE standard for floating point arithmetic. To find NaN values, you must use the `isnan` function.

pi Built-in Variable
 The ratio of the circumference of a circle to its diameter. Internally, `pi` is computed as `'4.0 * atan (1.0)'`.

e Built-in Variable
 The base of natural logarithms. The constant e satisfies the equation $\log(e) = 1$.

eps Built-in Variable
 The machine precision. More precisely, `eps` is the largest relative spacing between any two adjacent numbers in the machine's floating point system. This number is obviously system-dependent. On machines that support 64 bit IEEE floating point arithmetic, `eps` is approximately 2.2204×10^{-16} .

realmax

Built-in Variable

The largest floating point number that is representable. The actual value is system-dependent. On machines that support 64-bit IEEE floating point arithmetic, **realmax** is approximately 1.7977×10^{308} .

realmin

Built-in Variable

The smallest normalized floating point number that is representable. The actual value is system-dependent. On machines that support 64-bit IEEE floating point arithmetic, **realmin** is approximately 2.2251×10^{-308} .

20 Linear Algebra

This chapter documents the linear algebra functions of Octave. Reference material for many of these functions may be found in Golub and Van Loan, *Matrix Computations*, 2nd Ed., Johns Hopkins, 1989, and in LAPACK *Users' Guide*, SIAM, 1992.

20.1 Basic Matrix Functions

`aa = balance (a, opt)` Loadable Function
`[dd, aa] = balance (a, opt)` Loadable Function
`[cc, dd, aa, bb] = balance (a, b, opt)` Loadable Function

`[dd, aa] = balance (a)` returns `aa = dd \ a * dd`. `aa` is a matrix whose row and column norms are roughly equal in magnitude, and `dd = p * d`, where `p` is a permutation matrix and `d` is a diagonal matrix of powers of two. This allows the equilibration to be computed without roundoff. Results of eigenvalue calculation are typically improved by balancing first.

`[cc, dd, aa, bb] = balance (a, b)` returns `aa = cc*a*dd` and `bb = cc*b*dd`, where `aa` and `bb` have non-zero elements of approximately the same magnitude and `cc` and `dd` are permuted diagonal matrices as in `dd` for the algebraic eigenvalue problem.

The eigenvalue balancing option `opt` is selected as follows:

- "N", "n" No balancing; arguments copied, transformation(s) set to identity.
- "P", "p" Permute argument(s) to isolate eigenvalues where possible.
- "S", "s" Scale to improve accuracy of computed eigenvalues.
- "B", "b" Permute and scale, in that order. Rows/columns of `a` (and `b`) that are isolated by permutation are not scaled. This is the default behavior.

Algebraic eigenvalue balancing uses standard LAPACK routines.

Generalized eigenvalue problem balancing uses Ward's algorithm (SIAM Journal on Scientific and Statistical Computing, 1981).

`cond (a)` Function File
 Compute the (two-norm) condition number of a matrix. `cond (a)` is defined as `norm (a) * norm (inv (a))`, and is computed via a singular value decomposition.

`[d, rcond] = det (a)` Loadable Function
 Compute the determinant of `a` using LAPACK. Return an estimate of the reciprocal condition number if requested.

`dmult (a, b)` Function File
 If `a` is a vector of length `rows (b)`, return `diag (a) * b` (but computed much more efficiently).

dot (*x*, *y*, *dim*) Function File

Computes the dot product of two vectors. If *x* and *y* are matrices, calculate the dot-product along the first non-singleton dimension. If the optional argument *dim* is given, calculate the dot-product along this dimension.

lambda = **eig** (*a*) Loadable Function

[*v*, *lambda*] = **eig** (*a*) Loadable Function

The eigenvalues (and eigenvectors) of a matrix are computed in a several step process which begins with a Hessenberg decomposition, followed by a Schur decomposition, from which the eigenvalues are apparent. The eigenvectors, when desired, are computed by further manipulations of the Schur decomposition.

g = **givens** (*x*, *y*) Loadable Function

[*c*, *s*] = **givens** (*x*, *y*) Loadable Function

Return a 2×2 orthogonal matrix

$$G = \begin{bmatrix} c & s \\ -s' & c \end{bmatrix}$$

such that

$$G \begin{bmatrix} x \\ y \end{bmatrix} = \begin{bmatrix} * \\ 0 \end{bmatrix}$$

with *x* and *y* scalars.

For example,

```
givens (1, 1)
  =>  0.70711  0.70711
      -0.70711  0.70711
```

[*x*, *rcond*] = **inv** (*a*) Loadable Function

[*x*, *rcond*] = **inverse** (*a*) Loadable Function

Compute the inverse of the square matrix *a*. Return an estimate of the reciprocal condition number if requested, otherwise warn of an ill-conditioned matrix if the reciprocal condition number is small.

norm (*a*, *p*) Function File

Compute the *p*-norm of the matrix *a*. If the second argument is missing, *p* = 2 is assumed.

If *a* is a matrix:

p = 1 1-norm, the largest column sum of the absolute values of *a*.

p = 2 Largest singular value of *a*.

p = Inf Infinity norm, the largest row sum of the absolute values of *a*.

p = "fro" Frobenius norm of *a*, `sqrt (sum (diag (a' * a)))`.

If a is a vector or a scalar:

$p = \text{Inf}$ $\max (\text{abs} (a))$.

$p = -\text{Inf}$ $\min (\text{abs} (a))$.

other p -norm of a , $(\text{sum} (\text{abs} (a) .^ p)) ^ (1/p)$.

null (a , tol) Function File

Return an orthonormal basis of the null space of a .

The dimension of the null space is taken as the number of singular values of a not greater than tol . If the argument tol is missing, it is computed as

$\max (\text{size} (a)) * \max (\text{svd} (a)) * \text{eps}$

orth (a , tol) Function File

Return an orthonormal basis of the range space of a .

The dimension of the range space is taken as the number of singular values of a greater than tol . If the argument tol is missing, it is computed as

$\max (\text{size} (a)) * \max (\text{svd} (a)) * \text{eps}$

pinv (x , tol) Loadable Function

Return the pseudoinverse of x . Singular values less than tol are ignored.

If the second argument is omitted, it is assumed that

$\text{tol} = \max (\text{size} (x)) * \text{sigma_max} (x) * \text{eps}$,

where $\text{sigma_max} (x)$ is the maximal singular value of x .

rank (a , tol) Function File

Compute the rank of a , using the singular value decomposition. The rank is taken to be the number of singular values of a that are greater than the specified tolerance tol . If the second argument is omitted, it is taken to be

$\text{tol} = \max (\text{size} (a)) * \text{sigma}(1) * \text{eps}$;

where eps is machine precision and $\text{sigma}(1)$ is the largest singular value of a .

trace (a) Function File

Compute the trace of a , $\text{sum} (\text{diag} (a))$.

20.2 Matrix Factorizations

chol (*a*) Loadable Function
 Compute the Cholesky factor, *r*, of the symmetric positive definite matrix *a*, where $R^T R = A$.

h = **hess** (*a*) Loadable Function
[p, h] = hess (*a*) Loadable Function

Compute the Hessenberg decomposition of the matrix *a*.

The Hessenberg decomposition is usually used as the first step in an eigenvalue computation, but has other applications as well (see Golub, Nash, and Van Loan, IEEE Transactions on Automatic Control, 1979). The Hessenberg decomposition is

$$A = PHP^T$$

where *P* is a square unitary matrix ($P^H P = I$), and *H* is upper Hessenberg ($H_{i,j} = 0, \forall i \geq j + 1$).

[l, u, p] = lu (*a*) Loadable Function

Compute the LU decomposition of *a*, using subroutines from LAPACK. The result is returned in a permuted form, according to the optional return value *p*. For example, given the matrix **a** = [1, 2; 3, 4],

$$[l, u, p] = \text{lu} (a)$$

returns

l =

```
1.00000  0.00000
0.33333  1.00000
```

u =

```
3.00000  4.00000
0.00000  0.66667
```

p =

```
0  1
1  0
```

The matrix is not required to be square..

[q, r, p] = qr (*a*) Loadable Function

Compute the QR factorization of *a*, using standard LAPACK subroutines. For example, given the matrix **a** = [1, 2; 3, 4],

$$[q, r] = \text{qr} (a)$$

returns

```

q =
    -0.31623  -0.94868
    -0.94868   0.31623

r =
    -3.16228  -4.42719
     0.00000  -0.63246

```

The `qr` factorization has applications in the solution of least squares problems

$$\min_x \|Ax - b\|_2$$

for overdetermined systems of equations (i.e., A is a tall, thin matrix). The QR factorization is $QR = A$ where Q is an orthogonal matrix and R is upper triangular. The permuted QR factorization $[q, r, p] = \text{qr}(a)$ forms the QR factorization such that the diagonal entries of r are decreasing in magnitude order. For example, given the matrix $a = [1, 2; 3, 4]$,

$$[q, r, p] = \text{qr}(a)$$

returns

```

q =
    -0.44721  -0.89443
    -0.89443   0.44721

r =
    -4.47214  -3.13050
     0.00000   0.44721

p =
     0   1
     1   0

```

The permuted `qr` factorization $[q, r, p] = \text{qr}(a)$ factorization allows the construction of an orthogonal basis of $\text{span}(a)$.

`lambda = qz(a, b)`

Loadable Function

Generalized eigenvalue problem $Ax = sBx$, QZ decomposition. There are three ways to call this function:

1. `lambda = qz(A, B)`

Computes the generalized eigenvalues λ of $(A - sB)$.

2. `[AA, BB, Q, Z, V, W, lambda] = qz(A, B)`

Computes qz decomposition, generalized eigenvectors, and generalized eigenvalues of $(A - sB)$

$$AV = BV \text{diag}(\lambda)$$

$$W^T A = \text{diag}(\lambda) W^T B$$

$$AA = Q^T AZ, BB = Q^T BZ$$

with Q and Z orthogonal (unitary) = I

3. `[AA, BB, Z{, lambda}] = qz(A, B, opt)`

As in form [2], but allows ordering of generalized eigenpairs for (e.g.) solution of discrete time algebraic Riccati equations. Form 3 is not available for complex matrices, and does not compute the generalized eigenvectors V , W , nor the orthogonal matrix Q .

opt for ordering eigenvalues of the GEP pencil. The leading block of the revised pencil contains all eigenvalues that satisfy:

"N"	= unordered (default)
"S"	= small: leading block has all $ \lambda \leq 1$
"B"	= big: leading block has all $ \lambda > 1$
"-"	= negative real part: leading block has all eigenvalues in the open left half-plane
"+"	= nonnegative real part: leading block has all eigenvalues in the closed right half-plane

Note: `qz` performs permutation balancing, but not scaling (see `balance`). Order of output arguments was selected for compatibility with MATLAB

See also: `balance`, `dare`, `eig`, `schur`

`[aa, bb, q, z] = qzhess(a, b)` Function File

Compute the Hessenberg-triangular decomposition of the matrix pencil (a, b) , returning $aa = q * a * z$, $bb = q * b * z$, with q and z orthogonal. For example,

```
[aa, bb, q, z] = qzhess([1, 2; 3, 4], [5, 6; 7, 8])
⇒ aa = [ -3.02244, -4.41741; 0.92998, 0.69749 ]
⇒ bb = [ -8.60233, -9.99730; 0.00000, -0.23250 ]
⇒ q = [ -0.58124, -0.81373; -0.81373, 0.58124 ]
⇒ z = [ 1, 0; 0, 1 ]
```

The Hessenberg-triangular decomposition is the first step in Moler and Stewart's QZ decomposition algorithm.

Algorithm taken from Golub and Van Loan, *Matrix Computations*, 2nd edition.

`s = schur(a)` Loadable Function

`[u, s] = schur(a, opt)` Loadable Function

The Schur decomposition is used to compute eigenvalues of a square matrix, and has applications in the solution of algebraic Riccati equations in control (see `are` and `dare`). `schur` always returns $S = U^T A U$ where U is a unitary matrix ($U^T U$ is identity) and S is upper triangular. The eigenvalues of A (and S) are the diagonal elements of S . If the matrix A is real, then the real Schur decomposition is computed, in which the matrix U is orthogonal and S is block upper triangular with blocks of

size at most 2×2 along the diagonal. The diagonal elements of S (or the eigenvalues of the 2×2 blocks, when appropriate) are the eigenvalues of A and S .

The eigenvalues are optionally ordered along the diagonal according to the value of `opt`. `opt = "a"` indicates that all eigenvalues with negative real parts should be moved to the leading block of S (used in `are`), `opt = "d"` indicates that all eigenvalues with magnitude less than one should be moved to the leading block of S (used in `dare`), and `opt = "u"`, the default, indicates that no ordering of eigenvalues should occur. The leading k columns of U always span the A -invariant subspace corresponding to the k leading eigenvalues of S .

`s = svd (a)` Loadable Function
`[u, s, v] = svd (a)` Loadable Function
 Compute the singular value decomposition of a

$$A = U\Sigma V^H$$

The function `svd` normally returns the vector of singular values. If asked for three return values, it computes U , S , and V . For example,

```
svd (hilb (3))
```

returns

```
ans =
```

```
1.4083189
0.1223271
0.0026873
```

and

```
[u, s, v] = svd (hilb (3))
```

returns

```
u =
```

```
-0.82704  0.54745  0.12766
-0.45986 -0.52829 -0.71375
-0.32330 -0.64901  0.68867
```

```
s =
```

```
1.40832  0.00000  0.00000
0.00000  0.12233  0.00000
0.00000  0.00000  0.00269
```

```
v =
```

```
-0.82704  0.54745  0.12766
-0.45986 -0.52829 -0.71375
-0.32330 -0.64901  0.68867
```

If given a second argument, `svd` returns an economy-sized decomposition, eliminating the unnecessary rows or columns of u or v .

`[housv, beta, zer] = housh (x, j, z)` Function File
 Computes householder reflection vector `housv` to reflect `x` to be `j`th column of identity, i.e., $(I - \beta \text{housv} \text{housv}^T)x = e(j)$ inputs `x`: vector `j`: index into vector `z`: threshold for zero (usually should be the number 0) outputs: (see Golub and Van Loan) `beta`: If `beta = 0`, then no reflection need be applied (`zer` set to 0) `housv`: householder vector

`[u, h, nu] = krylov (a, v, k, eps1, pflg);` Function File
 construct orthogonal basis `U` of block Krylov subspace; `[v a*v a^2*v ... a^(k+1)*v]`; method used: householder reflections to guard against loss of orthogonality `eps1`: threshold for 0 (default: 1e-12) `pflg`: flag to use row pivoting (improves numerical behavior) 0 [default]: no pivoting; prints a warning message if trivial null space is corrupted 1 : pivoting performed
 outputs: `u`: orthogonal basis of block krylov subspace `h`: Hessenberg matrix; if `v` is a vector then `a u = u h` otherwise `h` is meaningless `nu`: dimension of span of krylov subspace (based on `eps1`) if `b` is a vector and `k > m-1`, `krylov` returns `h =` the Hessenberg decomposition of `a`.
 Reference: Hodel and Misra, "Partial Pivoting in the Computation of Krylov Subspaces", to be submitted to Linear Algebra and its Applications

20.3 Functions of a Matrix

`expm (a)` Loadable Function
 Return the exponential of a matrix, defined as the infinite Taylor series

$$\exp(A) = I + A + \frac{A^2}{2!} + \frac{A^3}{3!} + \dots$$

The Taylor series is *not* the way to compute the matrix exponential; see Moler and Van Loan, *Nineteen Dubious Ways to Compute the Exponential of a Matrix*, SIAM Review, 1978. This routine uses Ward's diagonal Padé approximation method with three step preconditioning (SIAM Journal on Numerical Analysis, 1977). Diagonal Padé approximations are rational polynomials of matrices $D_q(a)^{-1}N_q(a)$ whose Taylor series matches the first $2q + 1$ terms of the Taylor series above; direct evaluation of the Taylor series (with the same preconditioning steps) may be desirable in lieu of the Padé approximation when $D_q(a)$ is ill-conditioned.

`logm (a)` Function File
 Compute the matrix logarithm of the square matrix `a`. Note that this is currently implemented in terms of an eigenvalue expansion and needs to be improved to be more robust.

`[result, error_estimate] = sqrtm (a)` Loadable Function
 Compute the matrix square root of the square matrix `a`.
 Ref: Nicholas J. Higham. A new `sqrtm` for MATLAB. Numerical Analysis Report No. 336, Manchester Centre for Computational Mathematics, Manchester, England, January 1999.

kron (*a*, *b*)

Function File

Form the kronecker product of two matrices, defined block by block as

$$x = [a(i, j) \ b]$$

For example,

```
kron (1:4, ones (3, 1))
⇒  1  2  3  4
    1  2  3  4
    1  2  3  4
```

x = syl (*a*, *b*, *c*)

Loadable Function

Solve the Sylvester equation

$$AX + XB + C = 0$$

using standard LAPACK subroutines. For example,

```
syl ([1, 2; 3, 4], [5, 6; 7, 8], [9, 10; 11, 12])
⇒ [ -0.50000, -0.66667; -0.66667, -0.50000 ]
```

21 Nonlinear Equations

Octave can solve sets of nonlinear equations of the form

$$f(x) = 0$$

using the function `fsolve`, which is based on the MINPACK subroutine `hybrd`.

`[x, info, msg] = fsolve (fcn, x0)` Loadable Function

Given `fcn`, the name of a function of the form `f (x)` and an initial starting point `x0`, `fsolve` solves the set of equations such that `f(x) == 0`.

If `fcn` is a two-element string array, the first element names the function `f` described above, and the second element names a function of the form `j (x)` to compute the Jacobian matrix with elements

$$J = \frac{\partial f_i}{\partial x_j}$$

You can use the function `fsolve_options` to set optional parameters for `fsolve`.

`fsolve_options (opt, val)` Loadable Function

When called with two arguments, this function allows you set options parameters for the function `fsolve`. Given one argument, `fsolve_options` returns the value of the corresponding option. If no arguments are supplied, the names of all the available options and their current values are displayed.

Options include

"tolerance"

Nonnegative relative tolerance.

Here is a complete example. To solve the set of equations

$$\begin{aligned} -2x^2 + 3xy + 4 \sin(y) - 6 &= 0 \\ 3x^2 - 2xy^2 + 3 \cos(x) + 4 &= 0 \end{aligned}$$

you first need to write a function to compute the value of the given function. For example:

```
function y = f (x)
  y(1) = -2*x(1)^2 + 3*x(1)*x(2) + 4*sin(x(2)) - 6;
  y(2) = 3*x(1)^2 - 2*x(1)*x(2)^2 + 3*cos(x(1)) + 4;
endfunction
```

Then, call `fsolve` with a specified initial condition to find the roots of the system of equations. For example, given the function `f` defined above,

```
[x, info] = fsolve ("f", [1; 2])
```

results in the solution

```
x =  
  
    0.57983  
    2.54621
```

```
info = 1
```

A value of `info = 1` indicates that the solution has converged.

The function `perror` may be used to print English messages corresponding to the numeric error codes. For example,

```
perror ("fsolve", 1)  
  ─ solution converged to requested tolerance
```

22 Quadrature

22.1 Functions of One Variable

`[v, ier, nfun, err] = quad (f, a, b, tol, sing)` Loadable Function

Integrate a nonlinear function of one variable using Quadpack. The first argument is the name of the function, the function handle or the inline function to call to compute the value of the integrand. It must have the form

$$y = f(x)$$

where y and x are scalars.

The second and third arguments are limits of integration. Either or both may be infinite.

The optional argument *tol* is a vector that specifies the desired accuracy of the result. The first element of the vector is the desired absolute tolerance, and the second element is the desired relative tolerance. To choose a relative test only, set the absolute tolerance to zero. To choose an absolute test only, set the relative tolerance to zero.

The optional argument *sing* is a vector of values at which the integrand is known to be singular.

The result of the integration is returned in *v* and *ier* contains an integer error code (0 indicates a successful integration). The value of *nfun* indicates how many function evaluations were required, and *err* contains an estimate of the error in the solution.

You can use the function `quad_options` to set optional parameters for `quad`.

`quad_options (opt, val)` Loadable Function

When called with two arguments, this function allows you set options parameters for the function `quad`. Given one argument, `quad_options` returns the value of the corresponding option. If no arguments are supplied, the names of all the available options and their current values are displayed.

Options include

"absolute tolerance"

Absolute tolerance; may be zero for pure relative error test.

"relative tolerance"

Nonnegative relative tolerance. If the absolute tolerance is zero, the relative tolerance must be greater than or equal to `max (50*eps, 0.5e-28)`.

Here is an example of using `quad` to integrate the function

$$f(x) = x \sin(1/x) \sqrt{|1-x|}$$

from $x = 0$ to $x = 3$.

This is a fairly difficult integration (plot the function over the range of integration to see why).

The first step is to define the function:

```
function y = f (x)
  y = x .* sin (1 ./ x) .* sqrt (abs (1 - x));
endfunction
```

Note the use of the ‘dot’ forms of the operators. This is not necessary for the call to `quad`, but it makes it much easier to generate a set of points for plotting (because it makes it possible to call the function with a vector argument to produce a vector result).

Then we simply call `quad`:

```
[v, ier, nfun, err] = quad ("f", 0, 3)
⇒ 1.9819
⇒ 1
⇒ 5061
⇒ 1.1522e-07
```

Although `quad` returns a nonzero value for `ier`, the result is reasonably accurate (to see why, examine what happens to the result if you move the lower bound to 0.1, then 0.01, then 0.001, etc.).

22.2 Orthogonal Collocation

`[r, amat, bmat, q] = colloc (n, "left", "right")` Loadable Function

Compute derivative and integral weight matrices for orthogonal collocation using the subroutines given in J. Villadsen and M. L. Michelsen, *Solution of Differential Equation Models by Polynomial Approximation*.

Here is an example of using `colloc` to generate weight matrices for solving the second order differential equation $u' - \alpha u'' = 0$ with the boundary conditions $u(0) = 0$ and $u(1) = 1$.

First, we can generate the weight matrices for n points (including the endpoints of the interval), and incorporate the boundary conditions in the right hand side (for a specific value of α).

```
n = 7;
alpha = 0.1;
[r, a, b] = colloc (n-2, "left", "right");
at = a(2:n-1,2:n-1);
bt = b(2:n-1,2:n-1);
rhs = alpha * b(2:n-1,n) - a(2:n-1,n);
```

Then the solution at the roots r is

```
u = [ 0; (at - alpha * bt) \ rhs; 1]
⇒ [ 0.00; 0.004; 0.01 0.00; 0.12; 0.62; 1.00 ]
```

23 Differential Equations

Octave has two built-in functions for solving differential equations. Both are based on reliable ODE solvers written in Fortran.

23.1 Ordinary Differential Equations

The function `lsode` can be used to solve ODEs of the form

$$\frac{dx}{dt} = f(x, t)$$

using Hindmarsh's ODE solver LSODE.

`[x, istate, msg] lsode (fcn, x_0, t, t_crit)` Loadable Function

Solve the set of differential equations

$$\frac{dx}{dt} = f(x, t)$$

with

$$x(t_0) = x_0$$

The solution is returned in the matrix `x`, with each row corresponding to an element of the vector `t`. The first element of `t` should be `t_0` and should correspond to the initial state of the system `x_0`, so that the first row of the output is `x_0`.

The first argument, `fcn`, is a string that names the function to call to compute the vector of right hand sides for the set of equations. The function must have the form

$$xdot = \mathbf{f}(x, t)$$

in which `xdot` and `x` are vectors and `t` is a scalar.

If `fcn` is a two-element string array, the first element names the function `f` described above, and the second element names a function to compute the Jacobian of `f`. The Jacobian function must have the form

$$jac = \mathbf{j}(x, t)$$

in which `jac` is the matrix of partial derivatives

$$J = \frac{\partial f_i}{\partial x_j} = \begin{bmatrix} \frac{\partial f_1}{\partial x_1} & \frac{\partial f_1}{\partial x_2} & \cdots & \frac{\partial f_1}{\partial x_N} \\ \frac{\partial f_2}{\partial x_1} & \frac{\partial f_2}{\partial x_2} & \cdots & \frac{\partial f_2}{\partial x_N} \\ \vdots & \vdots & \ddots & \vdots \\ \frac{\partial f_3}{\partial x_1} & \frac{\partial f_3}{\partial x_2} & \cdots & \frac{\partial f_3}{\partial x_N} \end{bmatrix}$$

The second and third arguments specify the initial state of the system, `x_0`, and the initial value of the independent variable `t_0`.

The fourth argument is optional, and may be used to specify a set of times that the ODE solver should not integrate past. It is useful for avoiding difficulties with singularities and points where there is a discontinuity in the derivative.

After a successful computation, the value of `istate` will be 2 (consistent with the Fortran version of LSODE).

If the computation is not successful, `istate` will be something other than 2 and `msg` will contain additional information.

You can use the function `lsode_options` to set optional parameters for `lsode`.

lsode_options (*opt, val*) Loadable Function

When called with two arguments, this function allows you set options parameters for the function `lsode`. Given one argument, `lsode_options` returns the value of the corresponding option. If no arguments are supplied, the names of all the available options and their current values are displayed.

Options include

"absolute tolerance"

Absolute tolerance. May be either vector or scalar. If a vector, it must match the dimension of the state vector.

"relative tolerance"

Relative tolerance parameter. Unlike the absolute tolerance, this parameter may only be a scalar.

The local error test applied at each integration step is

$$\text{abs}(\text{local error in } x(i)) \leq \text{rtol} * \text{abs}(y(i)) + \text{atol}(i)$$

"integration method"

A string specifying the method of integration to use to solve the ODE system. Valid values are

"adams"

"non-stiff"

No Jacobian used (even if it is available).

"bdf"

"stiff"

Use stiff backward differentiation formula (BDF) method. If a function to compute the Jacobian is not supplied, `lsode` will compute a finite difference approximation of the Jacobian matrix.

"initial step size"

The step size to be attempted on the first step (default is determined automatically).

"maximum order"

Restrict the maximum order of the solution method. If using the Adams method, this option must be between 1 and 12. Otherwise, it must be between 1 and 5, inclusive.

"maximum step size"

Setting the maximum stepsize will avoid passing over very large regions (default is not specified).

"minimum step size"

The minimum absolute step size allowed (default is 0).

"step limit"

Maximum number of steps allowed (default is 100000).

Here is an example of solving a set of three differential equations using `lsode`. Given the function

```
function xdot = f (x, t)

    xdot = zeros (3,1);

    xdot(1) = 77.27 * (x(2) - x(1)*x(2) + x(1) \
        - 8.375e-06*x(1)^2);
    xdot(2) = (x(3) - x(1)*x(2) - x(2)) / 77.27;
    xdot(3) = 0.161*(x(1) - x(3));

endfunction
```

and the initial condition $x_0 = [4; 1.1; 4]$, the set of equations can be integrated using the command

```
t = linspace (0, 500, 1000);

y = lsode ("f", x0, t);
```

If you try this, you will see that the value of the result changes dramatically between $t = 0$ and 5, and again around $t = 305$. A more efficient set of output points might be

```
t = [0, logspace (-1, log10(303), 150), \
    logspace (log10(304), log10(500), 150)];
```

Octave also includes ODESSA, a modification of LSODE that allows for the computation of parametric sensitivity information simultaneously with the solution of the set of ODEs.

$[x, sx, istate, msg]$ **odessa** (*fcn*, *x_0*, *p*, *sx_0*, *t*, *t_crit*) Loadable Function
Solve the set of differential equations

$$\frac{dx}{dt} = f(x, t; p)$$

with

$$x(t_0) = x_0$$

and simultaneously compute the first-order sensitivity coefficients given by

$$s'(t) = j(t)*s(t) + df/dp$$

in which

$$\begin{aligned} s(t) &= dx(t)/dp && \text{(sensitivity functions)} \\ s'(t) &= d(dx(t)/dp)/dt \\ j(t) &= df(x,t;p)/dx(t) && \text{(Jacobian matrix)} \\ df/dp &= df(x,t;p)/dp && \text{(inhomogeneity matrix)} \end{aligned}$$

The solution is returned in the matrix x , with each row corresponding to an element of the vector t . The first element of t should be t_0 and should correspond to the initial state of the system x_0 , so that the first row of the output is x_0 .

The sensitivities are returned in a list of matrices, sx , with each element of the list corresponding to an element of the vector t .

The first argument, *fcn*, is a string that names the function to call to compute the vector of right hand sides for the set of equations. The function must have the form

$$\dot{x} = f(x, t, p)$$

in which \dot{x} and x are vectors and t is a scalar.

The variable p is a vector of parameters.

The fcn argument may also be an array of strings

```
["f"; "j"; "b"]
```

in which the first element names the function f described above, the second element names a function to compute the Jacobian of f , and the third element names a function to compute the inhomogeneity matrix.

The Jacobian function must have the form

$$j = j(x, t, p)$$

in which x , t , and p have the same meanings as above for the function f , and j is the matrix of partial derivatives

$$J = \frac{\partial f_i}{\partial x_j}$$

The function b must have the form

$$dfdp = b(x, t, p, c)$$

in which x , t , and p have the same meanings as above for the function f , c indicates which partial derivatives to return in $dfdp$. For example, if c is 2, you should return the vector

$$dfdp = \begin{matrix} df_i \\ \text{----} \\ dp_2 \end{matrix}, \quad i = 1:\text{length}(x)$$

The second argument, x_0 , specifies the initial state of the system.

The third argument, p , specifies the set of parameters.

The fourth argument, sx_0 specifies the initial values of the sensitivities.

The sixth argument is optional, and may be used to specify a set of times that the ODE solver should not integrate past. It is useful for avoiding difficulties with singularities and points where there is a discontinuity in the derivative.

After a successful computation, the value of $istate$ will be 2 (consistent with the Fortran version of ODESSA).

If the computation is not successful, $istate$ will be something other than 2 and msg will contain additional information.

You can use the function `odessa_options` to set optional parameters for `odessa`.

odessa_options (*opt*, *val*)

Loadable Function

When called with two arguments, this function allows you set options parameters for the function `odessa`. Given one argument, `odessa_options` returns the value of the corresponding option. If no arguments are supplied, the names of all the available options and their current values are displayed.

Options include

- "absolute tolerance"
 Absolute tolerance. May be either vector or scalar. If a vector, it must match the dimension of the state vector.
- "relative tolerance"
 Relative tolerance parameter. Unlike the absolute tolerance, this parameter may only be a scalar.
 The local error test applied at each integration step is

$$\text{abs}(\text{local error in } x(i)) \leq \text{rtol} * \text{abs}(y(i)) + \text{atol}(i)$$
- "integration method"
 A string specifying the method of integration to use to solve the ODE system. Valid values are
 "adams"
 "non-stiff"
 No Jacobian used (even if it is available).
 "bdf"
 "stiff" Use stiff backward differentiation formula (BDF) method. If a function to compute the Jacobian is not supplied, `lsode` will compute a finite difference approximation of the Jacobian matrix.
- "initial step size"
 The step size to be attempted on the first step (default is determined automatically).
- "maximum order"
 Restrict the maximum order of the solution method. If using the Adams method, this option must be between 1 and 12. Otherwise, it must be between 1 and 5, inclusive.
- "maximum step size"
 Setting the maximum stepsize will avoid passing over very large regions (default is not specified).
- "minimum step size"
 The minimum absolute step size allowed (default is 0).
- "step limit"
 Maximum number of steps allowed (default is 100000).

See Alan C. Hindmarsh, *ODEPACK, A Systematized Collection of ODE Solvers*, in Scientific Computing, R. S. Stepleman, editor, (1983) for more information about the inner workings of `lsode`.

23.2 Differential-Algebraic Equations

The function `daspk` can be used to solve DAEs of the form

$$0 = f(\dot{x}, x, t), \quad x(t = 0) = x_0, \dot{x}(t = 0) = \dot{x}_0$$

using Petzold's DAE solver `DASPK`.

`[x, xdot, istate, msg] = daspk (fcn, x_0, xdot_0, t, t_crit)` Loadable Function
Solve the set of differential-algebraic equations

$$0 = f(x, \dot{x}, t)$$

with

$$x(t_0) = x_0, \dot{x}(t_0) = \dot{x}_0$$

The solution is returned in the matrices `x` and `xdot`, with each row in the result matrices corresponding to one of the elements in the vector `t`. The first element of `t` should be `t_0` and correspond to the initial state of the system `x_0` and its derivative `xdot_0`, so that the first row of the output `x` is `x_0` and the first row of the output `xdot` is `xdot_0`.

The first argument, `fcn`, is a string that names the function to call to compute the vector of residuals for the set of equations. It must have the form

$$res = \mathbf{f} (x, xdot, t)$$

in which `x`, `xdot`, and `res` are vectors, and `t` is a scalar.

If `fcn` is a two-element string array, the first element names the function `f` described above, and the second element names a function to compute the modified Jacobian

$$J = \frac{\partial f}{\partial x} + c \frac{\partial f}{\partial \dot{x}}$$

The modified Jacobian function must have the form

$$jac = \mathbf{j} (x, xdot, t, c)$$

The second and third arguments to `daspk` specify the initial condition of the states and their derivatives, and the fourth argument specifies a vector of output times at which the solution is desired, including the time corresponding to the initial condition.

The set of initial states and derivatives are not strictly required to be consistent. If they are not consistent, you must use the `daspk_options` function to provide additional information so that `daspk` can compute a consistent starting point.

The fifth argument is optional, and may be used to specify a set of times that the DAE solver should not integrate past. It is useful for avoiding difficulties with singularities and points where there is a discontinuity in the derivative.

After a successful computation, the value of `istate` will be greater than zero (consistent with the Fortran version of `DASPK`).

If the computation is not successful, the value of `istate` will be less than zero and `msg` will contain additional information.

You can use the function `daspk_options` to set optional parameters for `daspk`.

daspk_options (*opt, val*) Loadable Function

When called with two arguments, this function allows you set options parameters for the function **daspk**. Given one argument, **daspk_options** returns the value of the corresponding option. If no arguments are supplied, the names of all the available options and their current values are displayed.

Options include

"absolute tolerance"

Absolute tolerance. May be either vector or scalar. If a vector, it must match the dimension of the state vector, and the relative tolerance must also be a vector of the same length.

"relative tolerance"

Relative tolerance. May be either vector or scalar. If a vector, it must match the dimension of the state vector, and the absolute tolerance must also be a vector of the same length.

The local error test applied at each integration step is

$$\begin{aligned} \text{abs (local error in } x(i)) \\ \leq \text{rtol}(i) * \text{abs}(Y(i)) + \text{atol}(i) \end{aligned}$$

"compute consistent initial condition"

Denoting the differential variables in the state vector by 'Y_d' and the algebraic variables by 'Y_a', **ddaspk** can solve one of two initialization problems:

1. Given Y_d, calculate Y_a and Y'_d
2. Given Y', calculate Y.

In either case, initial values for the given components are input, and initial guesses for the unknown components must also be provided as input. Set this option to 1 to solve the first problem, or 2 to solve the second (the default default is 0, so you must provide a set of initial conditions that are consistent).

If this option is set to a nonzero value, you must also set the "algebraic variables" option to declare which variables in the problem are algebraic.

"use initial condition heuristics"

Set to a nonzero value to use the initial condition heuristics options described below.

"initial condition heuristics"

A vector of the following parameters that can be used to control the initial condition calculation.

- | | |
|--------------|--|
| MXNIT | Maximum number of Newton iterations (default is 5). |
| MXNJ | Maximum number of Jacobian evaluations (default is 6). |
| MXNH | Maximum number of values of the artificial stepsize parameter to be tried if the "compute consistent initial condition" option has been set to 1 (default is 5). |

Note that the maximum number of Newton iterations allowed in all is `MXNIT*MXNJ*MXNH` if the `"compute consistent initial condition"` option has been set to 1 and `MXNIT*MXNJ` if it is set to 2.

`LSOFF` Set to a nonzero value to disable the linesearch algorithm (default is 0).

`STPTOL` Minimum scaled step in linesearch algorithm (default is $\text{eps}^{(2/3)}$).

`EPINIT` Swing factor in the Newton iteration convergence test. The test is applied to the residual vector, premultiplied by the approximate Jacobian. For convergence, the weighted RMS norm of this vector (scaled by the error weights) must be less than `EPINIT*EPCON`, where `EPCON = 0.33` is the analogous test constant used in the time steps. The default is `EPINIT = 0.01`.

`"print initial condition info"`

Set this option to a nonzero value to display detailed information about the initial condition calculation (default is 0).

`"exclude algebraic variables from error test"`

Set to a nonzero value to exclude algebraic variables from the error test. You must also set the `"algebraic variables"` option to declare which variables in the problem are algebraic (default is 0).

`"algebraic variables"`

A vector of the same length as the state vector. A nonzero element indicates that the corresponding element of the state vector is an algebraic variable (i.e., its derivative does not appear explicitly in the equation set). This option is required by the `compute consistent initial condition` and `exclude algebraic variables from error test` options.

`"enforce inequality constraints"`

Set to one of the following values to enforce the inequality constraints specified by the `"inequality constraint types"` option (default is 0).

1. To have constraint checking only in the initial condition calculation.
2. To enforce constraint checking during the integration.
3. To enforce both options 1 and 2.

`"inequality constraint types"`

A vector of the same length as the state specifying the type of inequality constraint. Each element of the vector corresponds to an element of the state and should be assigned one of the following codes

-2	Less than zero.
-1	Less than or equal to zero.
0	Not constrained.

- 1 Greater than or equal to zero.
- 2 Greater than zero.

This option only has an effect if the `"enforce inequality constraints"` option is nonzero.

`"initial step size"`

Differential-algebraic problems may occasionally suffer from severe scaling difficulties on the first step. If you know a great deal about the scaling of your problem, you can help to alleviate this problem by specifying an initial stepsize (default is computed automatically).

`"maximum order"`

Restrict the maximum order of the solution method. This option must be between 1 and 5, inclusive (default is 5).

`"maximum step size"`

Setting the maximum stepsize will avoid passing over very large regions (default is not specified).

Octave also includes DASSL, an earlier version of *Daspk*, and *dasrt*, which can be used to solve DAEs with constraints (stopping conditions).

`[x, xdot, t_out, istat, msg] = dasrt (fcn [, g], x_0, xdot_0, t [, t_crit])` Loadable Function

Solve the set of differential-algebraic equations

$$0 = f(x, \dot{x}, t)$$

with

$$x(t_0) = x_0, \dot{x}(t_0) = \dot{x}_0$$

with functional stopping criteria (root solving).

The solution is returned in the matrices `x` and `xdot`, with each row in the result matrices corresponding to one of the elements in the vector `t_out`. The first element of `t` should be `t_0` and correspond to the initial state of the system `x_0` and its derivative `xdot_0`, so that the first row of the output `x` is `x_0` and the first row of the output `xdot` is `xdot_0`.

The vector `t` provides an upper limit on the length of the integration. If the stopping condition is met, the vector `t_out` will be shorter than `t`, and the final element of `t_out` will be the point at which the stopping condition was met, and may not correspond to any element of the vector `t`.

The first argument, `fcn`, is a string that names the function to call to compute the vector of residuals for the set of equations. It must have the form

$$res = f(x, xdot, t)$$

in which `x`, `xdot`, and `res` are vectors, and `t` is a scalar.

If `fcn` is a two-element string array, the first element names the function `f` described above, and the second element names a function to compute the modified Jacobian

$$J = \frac{\partial f}{\partial x} + c \frac{\partial f}{\partial \dot{x}}$$

The modified Jacobian function must have the form

$$jac = j(x, \dot{x}, t, c)$$

The optional second argument names a function that defines the constraint functions whose roots are desired during the integration. This function must have the form

$$g_out = g(x, t)$$

and return a vector of the constraint function values. If the value of any of the constraint functions changes sign, DASRT will attempt to stop the integration at the point of the sign change.

If the name of the constraint function is omitted, `dasrt` solves the same problem as `daspk` or `dassl`.

Note that because of numerical errors in the constraint functions due to roundoff and integration error, DASRT may return false roots, or return the same root at two or more nearly equal values of T . If such false roots are suspected, the user should consider smaller error tolerances or higher precision in the evaluation of the constraint functions.

If a root of some constraint function defines the end of the problem, the input to DASRT should nevertheless allow integration to a point slightly past that root, so that DASRT can locate the root by interpolation.

The third and fourth arguments to `dasrt` specify the initial condition of the states and their derivatives, and the fourth argument specifies a vector of output times at which the solution is desired, including the time corresponding to the initial condition.

The set of initial states and derivatives are not strictly required to be consistent. In practice, however, DASSL is not very good at determining a consistent set for you, so it is best if you ensure that the initial values result in the function evaluating to zero.

The sixth argument is optional, and may be used to specify a set of times that the DAE solver should not integrate past. It is useful for avoiding difficulties with singularities and points where there is a discontinuity in the derivative.

After a successful computation, the value of `istate` will be greater than zero (consistent with the Fortran version of DASSL).

If the computation is not successful, the value of `istate` will be less than zero and `msg` will contain additional information.

You can use the function `dasrt_options` to set optional parameters for `dasrt`.

`dasrt_options` (*opt*, *val*)

Loadable Function

When called with two arguments, this function allows you set options parameters for the function `dasrt`. Given one argument, `dasrt_options` returns the value of the corresponding option. If no arguments are supplied, the names of all the available options and their current values are displayed.

Options include

"absolute tolerance"

Absolute tolerance. May be either vector or scalar. If a vector, it must match the dimension of the state vector, and the relative tolerance must also be a vector of the same length.

"relative tolerance"

Relative tolerance. May be either vector or scalar. If a vector, it must match the dimension of the state vector, and the absolute tolerance must also be a vector of the same length.

The local error test applied at each integration step is

$$\text{abs}(\text{local error in } x(i)) \leq \text{rtol}(i) * \text{abs}(Y(i)) + \text{atol}(i) \blacksquare$$

"initial step size"

Differential-algebraic problems may occasionally suffer from severe scaling difficulties on the first step. If you know a great deal about the scaling of your problem, you can help to alleviate this problem by specifying an initial stepsize.

"maximum order"

Restrict the maximum order of the solution method. This option must be between 1 and 5, inclusive.

"maximum step size"

Setting the maximum stepsize will avoid passing over very large regions.

"step limit"

Maximum number of integration steps to attempt on a single call to the underlying Fortran code.

See K. E. Brenan, et al., *Numerical Solution of Initial-Value Problems in Differential-Algebraic Equations*, North-Holland (1989) for more information about the implementation of DASSL.

24 Optimization

24.1 Linear Programming

24.2 Quadratic Programming

24.3 Nonlinear Programming

24.4 Linear Least Squares

$[beta, v, r] = \mathbf{gls}(y, x, o)$ Function File

Generalized least squares estimation for the multivariate model $y = xb + e$ with $\bar{e} = 0$ and $\text{cov}(\text{vec}(e)) = (s^2)o$, where y is a $t \times p$ matrix, x is a $t \times k$ matrix, b is a $k \times p$ matrix, e is a $t \times p$ matrix, and o is a $tp \times tp$ matrix.

Each row of y and x is an observation and each column a variable. The return values $beta$, v , and r are defined as follows.

$beta$ The GLS estimator for b .
 v The GLS estimator for s^2 .
 r The matrix of GLS residuals, $r = y - xbeta$.

$[beta, sigma, r] = \mathbf{ols}(y, x)$ Function File

Ordinary least squares estimation for the multivariate model $y = xb + e$ with $\bar{e} = 0$, and $\text{cov}(\text{vec}(e)) = \text{kron}(s, I)$ where y is a $t \times p$ matrix, x is a $t \times k$ matrix, b is a $k \times p$ matrix, and e is a $t \times p$ matrix.

Each row of y and x is an observation and each column a variable.

The return values $beta$, $sigma$, and r are defined as follows.

$beta$ The OLS estimator for b , $beta = \text{pinv}(x) * y$, where $\text{pinv}(x)$ denotes the pseudoinverse of x .
 $sigma$ The OLS estimator for the matrix s ,

$$sigma = (y - x * beta)'$$

$$* (y - x * beta)$$

$$/ (t - \text{rank}(x))$$

 r The matrix of OLS residuals, $r = y - x * beta$.

25 Statistics

I hope that someday Octave will include more statistics functions. If you would like to help improve Octave in this area, please contact bug-octave@bevo.che.wisc.edu.

25.1 Basic Statistical Functions

mean (*x*, *dim*, *opt*) Function File

If *x* is a vector, compute the mean of the elements of *x*

$$\text{mean}(x) = \bar{x} = \frac{1}{N} \sum_{i=1}^N x_i$$

If *x* is a matrix, compute the mean for each column and return them in a row vector.

With the optional argument *opt*, the kind of mean computed can be selected. The following options are recognized:

"a" Compute the (ordinary) arithmetic mean. This is the default.

"g" Compute the geometric mean.

"h" Compute the harmonic mean.

If the optional argument *dim* is supplied, work along dimension *dim*.

Both *dim* and *opt* are optional. If both are supplied, either may appear first.

median (*x*) Function File

If *x* is a vector, compute the median value of the elements of *x*.

$$\text{median}(x) = \begin{cases} x(\lceil N/2 \rceil), & N \text{ odd;} \\ (x(N/2) + x(N/2 + 1))/2, & N \text{ even.} \end{cases}$$

If *x* is a matrix, compute the median value for each column and return them in a row vector.

std (*x*) Function File

std (*x*, *opt*) Function File

std (*x*, *opt*, *dim*) Function File

If *x* is a vector, compute the standard deviation of the elements of *x*.

$$\text{std}(x) = \sigma(x) = \sqrt{\frac{\sum_{i=1}^N (x_i - \bar{x})^2}{N - 1}}$$

If *x* is a matrix, compute the standard deviation for each column and return them in a row vector.

The argument *opt* determines the type of normalization to use. Valid values are

- 0: normalizes with $N-1$, provides the square root of best unbiased estimator of the variance [default]
- 1: normalizes with N , this provides the square root of the second moment around the mean

The third argument *dim* determines the dimension along which the standard deviation is calculated.

cov (*x*, *y*) Function File

If each row of *x* and *y* is an observation and each column is a variable, the (*i*, *j*)-th entry of **cov** (*x*, *y*) is the covariance between the *i*-th variable in *x* and the *j*-th variable in *y*. If called with one argument, compute **cov** (*x*, *x*).

corrcoef (*x*, *y*) Function File

If each row of *x* and *y* is an observation and each column is a variable, the (*i*, *j*)-th entry of **corrcoef** (*x*, *y*) is the correlation between the *i*-th variable in *x* and the *j*-th variable in *y*. If called with one argument, compute **corrcoef** (*x*, *x*).

kurtosis (*x*, *dim*) Function File

If *x* is a vector of length N , return the kurtosis

$$\text{kurtosis}(x) = \frac{1}{N\sigma(x)^4} \sum_{i=1}^N (x_i - \bar{x})^4 - 3$$

of *x*. If *x* is a matrix, return the kurtosis over the first non-singleton dimension. The optional argument *dim* can be given to force the kurtosis to be given over that dimension.

mahalanobis (*x*, *y*) Function File

Return the Mahalanobis' D-square distance between the multivariate samples *x* and *y*, which must have the same number of components (columns), but may have a different number of observations (rows).

skewness (*x*, *dim*) Function File

If *x* is a vector of length n , return the skewness

$$\text{skewness}(x) = \frac{1}{N\sigma(x)^3} \sum_{i=1}^N (x_i - \bar{x})^3$$

of *x*. If *x* is a matrix, return the skewness along the first non-singleton dimension of the matrix. If the optional *dim* argument is given, operate along this dimension.

values (*x*) Function File

Return the different values in a column vector, arranged in ascending order.

var (*x*) Function File

For vector arguments, return the (real) variance of the values. For matrix arguments, return a row vector containing the variance for each column.

The argument *opt* determines the type of normalization to use. Valid values are

- 0: normalizes with N-1, provides the square root of best unbiased estimator of the variance [default]
- 1: normalizes with N, this provides the square root of the second moment around the mean

The third argument *dim* determines the dimension along which the variance is calculated.

$[t, l_x] = \mathbf{table}(x)$ Function File

$[t, l_x, l_y] = \mathbf{table}(x, y)$ Function File

Create a contingency table *t* from data vectors. The *l* vectors are the corresponding levels.

Currently, only 1- and 2-dimensional tables are supported.

studentize (*x*, *dim*) Function File

If *x* is a vector, subtract its mean and divide by its standard deviation.

If *x* is a matrix, do the above along the first non-singleton dimension. If the optional argument *dim* is given then operate along this dimension.

statistics (*x*) Function File

If *x* is a matrix, return a matrix with the minimum, first quartile, median, third quartile, maximum, mean, standard deviation, skewness and kurtosis of the columns of *x* as its rows.

If *x* is a vector, treat it as a column vector.

spearman (*x*, *y*) Function File

Compute Spearman's rank correlation coefficient *rho* for each of the variables specified by the input arguments.

For matrices, each row is an observation and each column a variable; vectors are always observations and may be row or column vectors.

spearman (*x*) is equivalent to **spearman** (*x*, *x*).

For two data vectors *x* and *y*, Spearman's *rho* is the correlation of the ranks of *x* and *y*.

If *x* and *y* are drawn from independent distributions, *rho* has zero mean and variance $1 / (n - 1)$, and is asymptotically normally distributed.

run_count (*x*, *n*) Function File

Count the upward runs along the first non-singleton dimension of *x* of length 1, 2, ..., *n*-1 and greater than or equal to *n*. If the optional argument *dim* is given operate along this dimension

ranks (*x*, *dim*) Function File

If *x* is a vector, return the (column) vector of ranks of *x* adjusted for ties.

If *x* is a matrix, do the above for along the first non-singleton dimension. If the optional argument *dim* is given, operate along this dimension.

range (*x*) Function File

range (*x*, *dim*) Function File

If *x* is a vector, return the range, i.e., the difference between the maximum and the minimum, of the input data.

If *x* is a matrix, do the above for each column of *x*.

If the optional argument *dim* is supplied, work along dimension *dim*.

[q, s] = qqplot (*x*, *dist*, *params*) Function File

Perform a QQ-plot (quantile plot).

If *F* is the CDF of the distribution *dist* with parameters *params* and *G* its inverse, and *x* a sample vector of length *n*, the QQ-plot graphs ordinate $s(i) = i$ -th largest element of *x* versus abscissa $q(i) = G((i - 0.5)/n)$.

If the sample comes from *F* except for a transformation of location and scale, the pairs will approximately follow a straight line.

The default for *dist* is the standard normal distribution. The optional argument *params* contains a list of parameters of *dist*. For example, for a quantile plot of the uniform distribution on [2,4] and *x*, use

```
qqplot (x, "uniform", 2, 4)
```

If no output arguments are given, the data are plotted directly.

probit (*p*) Function File

For each component of *p*, return the probit (the quantile of the standard normal distribution) of *p*.

[p, y] = ppplot (*x*, *dist*, *params*) Function File

Perform a PP-plot (probability plot).

If *F* is the CDF of the distribution *dist* with parameters *params* and *x* a sample vector of length *n*, the PP-plot graphs ordinate $y(i) = F$ (*i*-th largest element of *x*) versus abscissa $p(i) = (i - 0.5)/n$. If the sample comes from *F*, the pairs will approximately follow a straight line.

The default for *dist* is the standard normal distribution. The optional argument *params* contains a list of parameters of *dist*. For example, for a probability plot of the uniform distribution on [2,4] and *x*, use

```
ppplot (x, "uniform", 2, 4)
```

If no output arguments are given, the data are plotted directly.

moment (*x*, *p*, *opt*, *dim*) Function File

If *x* is a vector, compute the *p*-th moment of *x*.

If *x* is a matrix, return the row vector containing the *p*-th moment of each column.

With the optional string *opt*, the kind of moment to be computed can be specified. If *opt* contains "c" or "a", central and/or absolute moments are returned. For example,

```
moment (x, 3, "ac")
```

computes the third central absolute moment of *x*.

If the optional argument *dim* is supplied, work along dimension *dim*.

meansq (*x*) Function File

meansq (*x*, *dim*) Function File

For vector arguments, return the mean square of the values. For matrix arguments, return a row vector containing the mean square of each column. With the optional *dim* argument, returns the mean squared of the values along this dimension

logit (*p*) Function File

For each component of *p*, return the logit $\log(p / (1-p))$ of *p*.

kendall (*x*, *y*) Function File

Compute Kendall's *tau* for each of the variables specified by the input arguments.

For matrices, each row is an observation and each column a variable; vectors are always observations and may be row or column vectors.

kendall (*x*) is equivalent to **kendall** (*x*, *x*).

For two data vectors *x*, *y* of common length *n*, Kendall's *tau* is the correlation of the signs of all rank differences of *x* and *y*; i.e., if both *x* and *y* have distinct entries, then

$$\tau = \frac{1}{n(n-1)} \sum_{i,j} \text{sign}(q_i - q_j) \text{sign}(r_i - r_j)$$

in which the q_i and r_i are the ranks of *x* and *y*, respectively.

If *x* and *y* are drawn from independent distributions, Kendall's *tau* is asymptotically normal with mean 0 and variance $(2 * (2n+5)) / (9 * n * (n-1))$.

iqr (*x*, *dim*) Function File

If *x* is a vector, return the interquartile range, i.e., the difference between the upper and lower quartile, of the input data.

If *x* is a matrix, do the above for first non singleton dimension of *x*. If the option *dim* argument is given, then operate along this dimension.

cut (*x*, *breaks*) Function File

Create categorical data out of numerical or continuous data by cutting into intervals.

If *breaks* is a scalar, the data is cut into that many equal-width intervals. If *breaks* is a vector of break points, the category has `length (breaks) - 1` groups.

The returned value is a vector of the same size as *x* telling which group each point in *x* belongs to. Groups are labelled from 1 to the number of groups; points outside the range of *breaks* are labelled by `NaN`.

cor (*x*, *y*) Function File

The (*i*, *j*)-th entry of `cor (x, y)` is the correlation between the *i*-th variable in *x* and the *j*-th variable in *y*.

For matrices, each row is an observation and each column a variable; vectors are always observations and may be row or column vectors.

`cor (x)` is equivalent to `cor (x, x)`.

cloglog (*x*) Function File

Return the complementary log-log function of *x*, defined as

$$- \log (- \log (x))$$

center (*x*) Function File

center (*x*, *dim*) Function File

If *x* is a vector, subtract its mean. If *x* is a matrix, do the above for each column. If the optional argument *dim* is given, perform the above operation along this dimension

25.2 Tests

`[pval, f, df_b, df_w] = anova (y, g)` Function File

Perform a one-way analysis of variance (ANOVA). The goal is to test whether the population means of data taken from *k* different groups are all equal.

Data may be given in a single vector *y* with groups specified by a corresponding vector of group labels *g* (e.g., numbers from 1 to *k*). This is the general form which does not impose any restriction on the number of data in each group or the group labels.

If *y* is a matrix and *g* is omitted, each column of *y* is treated as a group. This form is only appropriate for balanced ANOVA in which the numbers of samples from each group are all equal.

Under the null of constant means, the statistic *f* follows an F distribution with *df_b* and *df_w* degrees of freedom.

The p-value (1 minus the CDF of this distribution at *f*) is returned in *pval*.

If no output argument is given, the standard one-way ANOVA table is printed.

`[pval, chisq, df] = bartlett_test (x1, ...)` Function File

Perform a Bartlett test for the homogeneity of variances in the data vectors x_1, x_2, \dots, x_k , where $k > 1$.

Under the null of equal variances, the test statistic *chisq* approximately follows a chi-square distribution with *df* degrees of freedom.

The p-value (1 minus the CDF of this distribution at *chisq*) is returned in *pval*.

If no output argument is given, the p-value is displayed.

`[pval, chisq, df] = chisquare_test_homogeneity (x, y, c)` Function File

Given two samples x and y , perform a chisquare test for homogeneity of the null hypothesis that x and y come from the same distribution, based on the partition induced by the (strictly increasing) entries of c .

For large samples, the test statistic *chisq* approximately follows a chisquare distribution with $df = \text{length}(c)$ degrees of freedom.

The p-value (1 minus the CDF of this distribution at *chisq*) is returned in *pval*.

If no output argument is given, the p-value is displayed.

`[pval, chisq, df] = chisquare_test_independence (x)` Function File

Perform a chi-square test for independence based on the contingency table x . Under the null hypothesis of independence, *chisq* approximately has a chi-square distribution with *df* degrees of freedom.

The p-value (1 minus the CDF of this distribution at *chisq*) of the test is returned in *pval*.

If no output argument is given, the p-value is displayed.

`cor_test (x, y, alt, method)` Function File

Test whether two samples x and y come from uncorrelated populations.

The optional argument string *alt* describes the alternative hypothesis, and can be "!=" or "<>" (non-zero), ">" (greater than 0), or "<" (less than 0). The default is the two-sided case.

The optional argument string *method* specifies on which correlation coefficient the test should be based. If *method* is "pearson" (default), the (usual) Pearson's product moment correlation coefficient is used. In this case, the data should come from a bivariate normal distribution. Otherwise, the other two methods offer nonparametric alternatives. If *method* is "kendall", then Kendall's rank correlation tau is used. If *method* is "spearman", then Spearman's rank correlation rho is used. Only the first character is necessary.

The output is a structure with the following elements:

<i>pval</i>	The p-value of the test.
<i>stat</i>	The value of the test statistic.
<i>dist</i>	The distribution of the test statistic.

params The parameters of the null distribution of the test statistic.

alternative

The alternative hypothesis.

method The method used for testing.

If no output argument is given, the p-value is displayed.

`[pval, f, df_num, df_den] = f_test_regression (y, x, rr, r)` Function File

Perform an F test for the null hypothesis $rr * b = r$ in a classical normal regression model $y = X * b + e$.

Under the null, the test statistic f follows an F distribution with df_num and df_den degrees of freedom.

The p-value (1 minus the CDF of this distribution at f) is returned in *pval*.

If not given explicitly, $r = 0$.

If no output argument is given, the p-value is displayed.

`[pval, tsq] = hotelling_test (x, m)` Function File

For a sample x from a multivariate normal distribution with unknown mean and covariance matrix, test the null hypothesis that $\text{mean}(x) == m$.

Hotelling's T^2 is returned in *tsq*. Under the null, $(n - p)T^2 / (p(n - 1))$ has an F distribution with p and $n - p$ degrees of freedom, where n and p are the numbers of samples and variables, respectively.

The p-value of the test is returned in *pval*.

If no output argument is given, the p-value of the test is displayed.

`[pval, tsq] = hotelling_test_2 (x, y)` Function File

For two samples x from multivariate normal distributions with the same number of variables (columns), unknown means and unknown equal covariance matrices, test the null hypothesis $\text{mean}(x) == \text{mean}(y)$.

Hotelling's two-sample T^2 is returned in *tsq*. Under the null,

$$\frac{(n_x + n_y - p - 1) T^2}{p(n_x + n_y - 2)}$$

has an F distribution with p and $n_x + n_y - p - 1$ degrees of freedom, where n_x and n_y are the sample sizes and p is the number of variables.

The p-value of the test is returned in *pval*.

If no output argument is given, the p-value of the test is displayed.

`[pval, ks] = kolmogorov_smirnov_test (x, dist, params, alt)` Function File

Perform a Kolmogorov-Smirnov test of the null hypothesis that the sample x comes from the (continuous) distribution *dist*. I.e., if F and G are the CDFs corresponding to the sample and *dist*, respectively, then the null is that $F == G$.

The optional argument *params* contains a list of parameters of *dist*. For example, to test whether a sample x comes from a uniform distribution on $[2,4]$, use

```
kolmogorov_smirnov_test(x, "uniform", 2, 4)
```

With the optional argument string *alt*, the alternative of interest can be selected. If *alt* is "!=" or "<>", the null is tested against the two-sided alternative $F \neq G$. In this case, the test statistic *ks* follows a two-sided Kolmogorov-Smirnov distribution. If *alt* is ">", the one-sided alternative $F > G$ is considered. Similarly for "<", the one-sided alternative $F < G$ is considered. In this case, the test statistic *ks* has a one-sided Kolmogorov-Smirnov distribution. The default is the two-sided case.

The p-value of the test is returned in *pval*.

If no output argument is given, the p-value is displayed.

`[pval, ks, d] = kolmogorov_smirnov_test_2 (x, y, alt)` Function File

Perform a 2-sample Kolmogorov-Smirnov test of the null hypothesis that the samples *x* and *y* come from the same (continuous) distribution. I.e., if *F* and *G* are the CDFs corresponding to the *x* and *y* samples, respectively, then the null is that $F == G$.

With the optional argument string *alt*, the alternative of interest can be selected. If *alt* is "!=" or "<>", the null is tested against the two-sided alternative $F \neq G$. In this case, the test statistic *ks* follows a two-sided Kolmogorov-Smirnov distribution. If *alt* is ">", the one-sided alternative $F > G$ is considered. Similarly for "<", the one-sided alternative $F < G$ is considered. In this case, the test statistic *ks* has a one-sided Kolmogorov-Smirnov distribution. The default is the two-sided case.

The p-value of the test is returned in *pval*.

The third returned value, *d*, is the test statistic, the maximum vertical distance between the two cumulative distribution functions.

If no output argument is given, the p-value is displayed.

`[pval, k, df] = kruskal_wallis_test (x1, ...)` Function File

Perform a Kruskal-Wallis one-factor "analysis of variance".

Suppose a variable is observed for $k > 1$ different groups, and let *x1*, ..., *xk* be the corresponding data vectors.

Under the null hypothesis that the ranks in the pooled sample are not affected by the group memberships, the test statistic *k* is approximately chi-square with $df = k - 1$ degrees of freedom.

The p-value (1 minus the CDF of this distribution at *k*) is returned in *pval*.

If no output argument is given, the p-value is displayed.

`manova (y, g)` Function File

Perform a one-way multivariate analysis of variance (MANOVA). The goal is to test whether the *p*-dimensional population means of data taken from *k* different groups are all equal. All data are assumed drawn independently from *p*-dimensional normal distributions with the same covariance matrix.

The data matrix is given by *y*. As usual, rows are observations and columns are variables. The vector *g* specifies the corresponding group labels (e.g., numbers from 1 to *k*).

The LR test statistic (Wilks' Lambda) and approximate p-values are computed and displayed.

`[pval, chisq, df] = mcnemar_test (x)` Function File

For a square contingency table *x* of data cross-classified on the row and column variables, McNemar's test can be used for testing the null hypothesis of symmetry of the classification probabilities.

Under the null, *chisq* is approximately distributed as chisquare with *df* degrees of freedom.

The p-value (1 minus the CDF of this distribution at *chisq*) is returned in *pval*.

If no output argument is given, the p-value of the test is displayed.

`[pval, z] = prop_test_2 (x1, n1, x2, n2, alt)` Function File

If *x1* and *n1* are the counts of successes and trials in one sample, and *x2* and *n2* those in a second one, test the null hypothesis that the success probabilities *p1* and *p2* are the same. Under the null, the test statistic *z* approximately follows a standard normal distribution.

With the optional argument string *alt*, the alternative of interest can be selected. If *alt* is "!=" or "<>", the null is tested against the two-sided alternative $p1 \neq p2$. If *alt* is ">", the one-sided alternative $p1 > p2$ is used. Similarly for "<", the one-sided alternative $p1 < p2$ is used. The default is the two-sided case.

The p-value of the test is returned in *pval*.

If no output argument is given, the p-value of the test is displayed.

`[pval, chisq] = run_test (x)` Function File

Perform a chi-square test with 6 degrees of freedom based on the upward runs in the columns of *x*. Can be used to test whether *x* contains independent data.

The p-value of the test is returned in *pval*.

If no output argument is given, the p-value is displayed.

`[pval, b, n] = sign_test (x, y, alt)` Function File

For two matched-pair samples *x* and *y*, perform a sign test of the null hypothesis $\text{PROB}(x > y) == \text{PROB}(x < y) == 1/2$. Under the null, the test statistic *b* roughly follows a binomial distribution with parameters $n = \text{sum}(x \neq y)$ and $p = 1/2$.

With the optional argument *alt*, the alternative of interest can be selected. If *alt* is "!=" or "<>", the null hypothesis is tested against the two-sided alternative $\text{PROB}(x < y) \neq 1/2$. If *alt* is ">", the one-sided alternative $\text{PROB}(x > y) > 1/2$ ("x is stochastically greater than y") is considered. Similarly for "<", the one-sided alternative $\text{PROB}(x > y) < 1/2$ ("x is stochastically less than y") is considered. The default is the two-sided case.

The p-value of the test is returned in *pval*.

If no output argument is given, the p-value of the test is displayed.

`[pval, t, df] = t_test (x, m, alt)` Function File

For a sample x from a normal distribution with unknown mean and variance, perform a t-test of the null hypothesis $\text{mean}(x) = m$. Under the null, the test statistic t follows a Student distribution with $df = \text{length}(x) - 1$ degrees of freedom.

With the optional argument string alt , the alternative of interest can be selected. If alt is "!=" or "<>", the null is tested against the two-sided alternative $\text{mean}(x) \neq m$. If alt is ">", the one-sided alternative $\text{mean}(x) > m$ is considered. Similarly for "<", the one-sided alternative $\text{mean}(x) < m$ is considered. The default is the two-sided case.

The p-value of the test is returned in $pval$.

If no output argument is given, the p-value of the test is displayed.

`[pval, t, df] = t_test_2 (x, y, alt)` Function File

For two samples x and y from normal distributions with unknown means and unknown equal variances, perform a two-sample t-test of the null hypothesis of equal means. Under the null, the test statistic t follows a Student distribution with df degrees of freedom.

With the optional argument string alt , the alternative of interest can be selected. If alt is "!=" or "<>", the null is tested against the two-sided alternative $\text{mean}(x) \neq \text{mean}(y)$. If alt is ">", the one-sided alternative $\text{mean}(x) > \text{mean}(y)$ is used. Similarly for "<", the one-sided alternative $\text{mean}(x) < \text{mean}(y)$ is used. The default is the two-sided case.

The p-value of the test is returned in $pval$.

If no output argument is given, the p-value of the test is displayed.

`[pval, t, df] = t_test_regression (y, x, rr, r, alt)` Function File

Perform an t test for the null hypothesis $rr * b = r$ in a classical normal regression model $y = x * b + e$. Under the null, the test statistic t follows a t distribution with df degrees of freedom.

If r is omitted, a value of 0 is assumed.

With the optional argument string alt , the alternative of interest can be selected. If alt is "!=" or "<>", the null is tested against the two-sided alternative $rr * b \neq r$. If alt is ">", the one-sided alternative $rr * b > r$ is used. Similarly for "<", the one-sided alternative $rr * b < r$ is used. The default is the two-sided case.

The p-value of the test is returned in $pval$.

If no output argument is given, the p-value of the test is displayed.

`[pval, z] = u_test (x, y, alt)` Function File

For two samples x and y , perform a Mann-Whitney U-test of the null hypothesis $\text{PROB}(x > y) = 1/2 = \text{PROB}(x < y)$. Under the null, the test statistic z approximately follows a standard normal distribution. Note that this test is equivalent to the Wilcoxon rank-sum test.

With the optional argument string *alt*, the alternative of interest can be selected. If *alt* is "!=" or "<>", the null is tested against the two-sided alternative $\text{PROB}(x > y) \neq 1/2$. If *alt* is ">", the one-sided alternative $\text{PROB}(x > y) > 1/2$ is considered. Similarly for "<", the one-sided alternative $\text{PROB}(x > y) < 1/2$ is considered. The default is the two-sided case.

The p-value of the test is returned in *pval*.

If no output argument is given, the p-value of the test is displayed.

`[pval, f, df_num, df_den] = var_test (x, y, alt)` Function File

For two samples *x* and *y* from normal distributions with unknown means and unknown variances, perform an F-test of the null hypothesis of equal variances. Under the null, the test statistic *f* follows an F-distribution with *df_num* and *df_den* degrees of freedom.

With the optional argument string *alt*, the alternative of interest can be selected. If *alt* is "!=" or "<>", the null is tested against the two-sided alternative $\text{var}(x) \neq \text{var}(y)$. If *alt* is ">", the one-sided alternative $\text{var}(x) > \text{var}(y)$ is used. Similarly for "<", the one-sided alternative $\text{var}(x) < \text{var}(y)$ is used. The default is the two-sided case.

The p-value of the test is returned in *pval*.

If no output argument is given, the p-value of the test is displayed.

`[pval, t, df] = welch_test (x, y, alt)` Function File

For two samples *x* and *y* from normal distributions with unknown means and unknown and not necessarily equal variances, perform a Welch test of the null hypothesis of equal means. Under the null, the test statistic *t* approximately follows a Student distribution with *df* degrees of freedom.

With the optional argument string *alt*, the alternative of interest can be selected. If *alt* is "!=" or "<>", the null is tested against the two-sided alternative $\text{mean}(x) \neq m$. If *alt* is ">", the one-sided alternative $\text{mean}(x) > m$ is considered. Similarly for "<", the one-sided alternative $\text{mean}(x) < m$ is considered. The default is the two-sided case.

The p-value of the test is returned in *pval*.

If no output argument is given, the p-value of the test is displayed.

`[pval, z] = wilcoxon_test (x, y, alt)` Function File

For two matched-pair sample vectors *x* and *y*, perform a Wilcoxon signed-rank test of the null hypothesis $\text{PROB}(x > y) = 1/2$. Under the null, the test statistic *z* approximately follows a standard normal distribution.

With the optional argument string *alt*, the alternative of interest can be selected. If *alt* is "!=" or "<>", the null is tested against the two-sided alternative $\text{PROB}(x > y) \neq 1/2$. If *alt* is ">", the one-sided alternative $\text{PROB}(x > y) > 1/2$ is considered. Similarly for "<", the one-sided alternative $\text{PROB}(x > y) < 1/2$ is considered. The default is the two-sided case.

The p-value of the test is returned in *pval*.

If no output argument is given, the p-value of the test is displayed.

`[pval, z] = z_test (x, m, v, alt)` Function File

Perform a Z-test of the null hypothesis $\text{mean}(x) = m$ for a sample x from a normal distribution with unknown mean and known variance v . Under the null, the test statistic z follows a standard normal distribution.

With the optional argument string *alt*, the alternative of interest can be selected. If *alt* is "!=" or "<>", the null is tested against the two-sided alternative $\text{mean}(x) \neq m$. If *alt* is ">", the one-sided alternative $\text{mean}(x) > m$ is considered. Similarly for "<", the one-sided alternative $\text{mean}(x) < m$ is considered. The default is the two-sided case.

The p-value of the test is returned in *pval*.

If no output argument is given, the p-value of the test is displayed along with some information.

`[pval, z] = z_test_2 (x, y, v_x, v_y, alt)` Function File

For two samples x and y from normal distributions with unknown means and known variances v_x and v_y , perform a Z-test of the hypothesis of equal means. Under the null, the test statistic z follows a standard normal distribution.

With the optional argument string *alt*, the alternative of interest can be selected. If *alt* is "!=" or "<>", the null is tested against the two-sided alternative $\text{mean}(x) \neq \text{mean}(y)$. If *alt* is ">", the one-sided alternative $\text{mean}(x) > \text{mean}(y)$ is used. Similarly for "<", the one-sided alternative $\text{mean}(x) < \text{mean}(y)$ is used. The default is the two-sided case.

The p-value of the test is returned in *pval*.

If no output argument is given, the p-value of the test is displayed along with some information.

25.3 Models

`[theta, beta, dev, dl, d2l, p] = logistic_regression (y, x, print, theta, beta)` Function File

Perform ordinal logistic regression.

Suppose y takes values in k ordered categories, and let $\text{gamma}_i(x)$ be the cumulative probability that y falls in one of the first i categories given the covariate x . Then

$$[\text{theta}, \text{beta}] = \text{logistic_regression}(y, x)$$

fits the model

$$\text{logit}(\text{gamma}_i(x)) = \text{theta}_i - \text{beta}' * x, \quad i = 1, \dots, k-1$$

The number of ordinal categories, k , is taken to be the number of distinct values of $\text{round}(y)$. If k equals 2, y is binary and the model is ordinary logistic regression. The matrix x is assumed to have full column rank.

Given y only, $\text{theta} = \text{logistic_regression}(y)$ fits the model with baseline logit odds only.

The full form is

```
[theta, beta, dev, dl, d2l, gamma]
    = logistic_regression (y, x, print, theta, beta)
```

in which all output arguments and all input arguments except y are optional.

Setting $print$ to 1 requests summary information about the fitted model to be displayed. Setting $print$ to 2 requests information about convergence at each iteration. Other values request no information to be displayed. The input arguments $theta$ and $beta$ give initial estimates for $theta$ and $beta$.

The returned value dev holds minus twice the log-likelihood.

The returned values dl and $d2l$ are the vector of first and the matrix of second derivatives of the log-likelihood with respect to $theta$ and $beta$.

p holds estimates for the conditional distribution of y given x .

25.4 Distributions

beta_cdf (x , a , b) Function File
 For each element of x , returns the CDF at x of the beta distribution with parameters a and b , i.e., $\text{PROB}(\text{beta}(a, b) \leq x)$.

beta_inv (x , a , b) Function File
 For each component of x , compute the quantile (the inverse of the CDF) at x of the Beta distribution with parameters a and b .

beta_pdf (x , a , b) Function File
 For each element of x , returns the PDF at x of the beta distribution with parameters a and b .

beta_rnd (a , b , r , c) Function File
beta_rnd (a , b , sz) Function File
 Return an r by c or **size** (sz) matrix of random samples from the Beta distribution with parameters a and b . Both a and b must be scalar or of size r by c .
 If r and c are omitted, the size of the result matrix is the common size of a and b .

binomial_cdf (x , n , p) Function File
 For each element of x , compute the CDF at x of the binomial distribution with parameters n and p .

binomial_inv (x , n , p) Function File
 For each element of x , compute the quantile at x of the binomial distribution with parameters n and p .

binomial_pdf (x , n , p) Function File
 For each element of x , compute the probability density function (PDF) at x of the binomial distribution with parameters n and p .

binomial_rnd (n, p, r, c) Function File

binomial_rnd (n, p, sz) Function File

Return an r by c or a **size** (sz) matrix of random samples from the binomial distribution with parameters n and p . Both n and p must be scalar or of size r by c .

If r and c are omitted, the size of the result matrix is the common size of n and p .

cauchy_cdf ($x, lambda, sigma$) Function File

For each element of x , compute the cumulative distribution function (CDF) at x of the Cauchy distribution with location parameter $lambda$ and scale parameter $sigma$.

Default values are $lambda = 0$, $sigma = 1$.

cauchy_inv ($x, lambda, sigma$) Function File

For each element of x , compute the quantile (the inverse of the CDF) at x of the Cauchy distribution with location parameter $lambda$ and scale parameter $sigma$. Default values are $lambda = 0$, $sigma = 1$.

cauchy_pdf ($x, lambda, sigma$) Function File

For each element of x , compute the probability density function (PDF) at x of the Cauchy distribution with location parameter $lambda$ and scale parameter $sigma > 0$.

Default values are $lambda = 0$, $sigma = 1$.

cauchy_rnd ($lambda, sigma, r, c$) Function File

cauchy_rnd ($lambda, sigma, sz$) Function File

Return an r by c or a **size** (sz) matrix of random samples from the Cauchy distribution with parameters $lambda$ and $sigma$ which must both be scalar or of size r by c .

If r and c are omitted, the size of the result matrix is the common size of $lambda$ and $sigma$.

chisquare_cdf (x, n) Function File

For each element of x , compute the cumulative distribution function (CDF) at x of the chisquare distribution with n degrees of freedom.

chisquare_inv (x, n) Function File

For each element of x , compute the quantile (the inverse of the CDF) at x of the chisquare distribution with n degrees of freedom.

chisquare_pdf (x, n) Function File

For each element of x , compute the probability density function (PDF) at x of the chisquare distribution with k degrees of freedom.

chisquare_rnd (n, r, c) Function File

chisquare_rnd (n, sz) Function File

Return an r by c or a **size** (sz) matrix of random samples from the chisquare distribution with n degrees of freedom. n must be a scalar or of size r by c .

If r and c are omitted, the size of the result matrix is the size of n .

discrete_cdf (x, v, p) Function File

For each element of x , compute the cumulative distribution function (CDF) at x of a univariate discrete distribution which assumes the values in v with probabilities p .

discrete_inv (x, v, p) Function File

For each component of x , compute the quantile (the inverse of the CDF) at x of the univariate distribution which assumes the values in v with probabilities p .

discrete_pdf (x, v, p) Function File

For each element of x , compute the probability density function (PDF) at x of a univariate discrete distribution which assumes the values in v with probabilities p .

discrete_rnd (n, v, p) Function File

discrete_rnd (v, p, r, c) Function File

discrete_rnd (v, p, sz) Function File

Generate a row vector containing a random sample of size n from the univariate distribution which assumes the values in v with probabilities p . n must be a scalar.

If r and c are given create a matrix with r rows and c columns. Or if sz is a vector, create a matrix of size sz .

empirical_cdf ($x, data$) Function File

For each element of x , compute the cumulative distribution function (CDF) at x of the empirical distribution obtained from the univariate sample $data$.

empirical_inv ($x, data$) Function File

For each element of x , compute the quantile (the inverse of the CDF) at x of the empirical distribution obtained from the univariate sample $data$.

empirical_pdf ($x, data$) Function File

For each element of x , compute the probability density function (PDF) at x of the empirical distribution obtained from the univariate sample $data$.

empirical_rnd ($n, data$) Function File

empirical_rnd ($data, r, c$) Function File

empirical_rnd ($data, sz$) Function File

Generate a bootstrap sample of size n from the empirical distribution obtained from the univariate sample $data$.

If r and c are given create a matrix with r rows and c columns. Or if sz is a vector, create a matrix of size sz .

exponential_cdf (x , $lambda$) Function File

For each element of x , compute the cumulative distribution function (CDF) at x of the exponential distribution with parameter $lambda$.

The arguments can be of common size or scalar.

exponential_inv (x , $lambda$) Function File

For each element of x , compute the quantile (the inverse of the CDF) at x of the exponential distribution with parameter $lambda$.

exponential_pdf (x , $lambda$) Function File

For each element of x , compute the probability density function (PDF) of the exponential distribution with parameter $lambda$.

exponential_rnd ($lambda$, r , c) Function File

exponential_rnd ($lambda$, sz) Function File

Return an r by c matrix of random samples from the exponential distribution with parameter $lambda$, which must be a scalar or of size r by c . Or if sz is a vector, create a matrix of size sz .

If r and c are omitted, the size of the result matrix is the size of $lambda$.

f_cdf (x , m , n) Function File

For each element of x , compute the CDF at x of the F distribution with m and n degrees of freedom, i.e., $\text{PROB}(F(m, n) \leq x)$.

f_inv (x , m , n) Function File

For each component of x , compute the quantile (the inverse of the CDF) at x of the F distribution with parameters m and n .

f_pdf (x , m , n) Function File

For each element of x , compute the probability density function (PDF) at x of the F distribution with m and n degrees of freedom.

f_rnd (m , n , r , c) Function File

f_rnd (m , n , sz) Function File

Return an r by c matrix of random samples from the F distribution with m and n degrees of freedom. Both m and n must be scalar or of size r by c . If sz is a vector the random samples are in a matrix of size sz .

If r and c are omitted, the size of the result matrix is the common size of m and n .

gamma_cdf (x , a , b) Function File

For each element of x , compute the cumulative distribution function (CDF) at x of the Gamma distribution with parameters a and b .

gamma_inv (x, a, b) Function File
For each component of x , compute the quantile (the inverse of the CDF) at x of the Gamma distribution with parameters a and b .

gamma_pdf (x, a, b) Function File
For each element of x , return the probability density function (PDF) at x of the Gamma distribution with parameters a and b .

gamma_rnd (a, b, r, c) Function File
gamma_rnd (a, b, sz) Function File
Return an r by c or a **size** (sz) matrix of random samples from the Gamma distribution with parameters a and b . Both a and b must be scalar or of size r by c .
If r and c are omitted, the size of the result matrix is the common size of a and b .

geometric_cdf (x, p) Function File
For each element of x , compute the CDF at x of the geometric distribution with parameter p .

geometric_inv (x, p) Function File
For each element of x , compute the quantile at x of the geometric distribution with parameter p .

geometric_pdf (x, p) Function File
For each element of x , compute the probability density function (PDF) at x of the geometric distribution with parameter p .

geometric_rnd (p, r, c) Function File
geometric_rnd (p, sz) Function File
Return an r by c matrix of random samples from the geometric distribution with parameter p , which must be a scalar or of size r by c .
If r and c are given create a matrix with r rows and c columns. Or if sz is a vector, create a matrix of size sz .

hypergeometric_cdf (x, m, t, n) Function File
Compute the cumulative distribution function (CDF) at x of the hypergeometric distribution with parameters m , t , and n . This is the probability of obtaining not more than x marked items when randomly drawing a sample of size n without replacement from a population of total size t containing m marked items.
The parameters m , t , and n must positive integers with m and n not greater than t .

hypergeometric_inv (x, m, t, n) Function File

For each element of x , compute the quantile at x of the hypergeometric distribution with parameters m , t , and n .

The parameters m , t , and n must be positive integers with m and n not greater than t .

hypergeometric_pdf (x, m, t, n) Function File

Compute the probability density function (PDF) at x of the hypergeometric distribution with parameters m , t , and n . This is the probability of obtaining x marked items when randomly drawing a sample of size n without replacement from a population of total size t containing m marked items.

The arguments must be of common size or scalar.

hypergeometric_rnd (n_size, m, t, n) Function File

hypergeometric_rnd (m, t, n, r, c) Function File

hypergeometric_rnd (m, t, n, sz) Function File

Generate a row vector containing a random sample of size n_size from the hypergeometric distribution with parameters m , t , and n .

If r and c are given create a matrix with r rows and c columns. Or if sz is a vector, create a matrix of size sz .

The parameters m , t , and n must be positive integers with m and n not greater than t .

kolmogorov_smirnov_cdf (x, tol) Function File

Return the CDF at x of the Kolmogorov-Smirnov distribution,

$$Q(x) = \sum_{k=-\infty}^{\infty} (-1)^k \exp(-2k^2 x^2)$$

for $x > 0$.

The optional parameter tol specifies the precision up to which the series should be evaluated; the default is $tol = \text{eps}$.

laplace_cdf (x) Function File

For each element of x , compute the cumulative distribution function (CDF) at x of the Laplace distribution.

laplace_inv (x) Function File

For each element of x , compute the quantile (the inverse of the CDF) at x of the Laplace distribution.

laplace_pdf (x) Function File

For each element of x , compute the probability density function (PDF) at x of the Laplace distribution.

- laplace_rnd** (r, c) Function File
laplace_rnd (sz); Function File
Return an r by c matrix of random numbers from the Laplace distribution. Or if sz is a vector, create a matrix of sz .
- logistic_cdf** (x) Function File
For each component of x , compute the CDF at x of the logistic distribution.
- logistic_inv** (x) Function File
For each component of x , compute the quantile (the inverse of the CDF) at x of the logistic distribution.
- logistic_pdf** (x) Function File
For each component of x , compute the PDF at x of the logistic distribution.
- logistic_rnd** (r, c) Function File
logistic_rnd (sz) Function File
Return an r by c matrix of random numbers from the logistic distribution. Or if sz is a vector, create a matrix of sz .
- lognormal_cdf** (x, a, v) Function File
For each element of x , compute the cumulative distribution function (CDF) at x of the lognormal distribution with parameters a and v . If a random variable follows this distribution, its logarithm is normally distributed with mean $\log(a)$ and variance v . Default values are $a = 1, v = 1$.
- lognormal_inv** (x, a, v) Function File
For each element of x , compute the quantile (the inverse of the CDF) at x of the lognormal distribution with parameters a and v . If a random variable follows this distribution, its logarithm is normally distributed with mean $\log(a)$ and variance v . Default values are $a = 1, v = 1$.
- lognormal_pdf** (x, a, v) Function File
For each element of x , compute the probability density function (PDF) at x of the lognormal distribution with parameters a and v . If a random variable follows this distribution, its logarithm is normally distributed with mean $\log(a)$ and variance v . Default values are $a = 1, v = 1$.
- lognormal_rnd** (a, v, r, c) Function File
lognormal_rnd (a, v, sz) Function File
Return an r by c matrix of random samples from the lognormal distribution with parameters a and v . Both a and v must be scalar or of size r by c . Or if sz is a vector, create a matrix of size sz .
If r and c are omitted, the size of the result matrix is the common size of a and v .

normal_cdf (x, m, v) Function File

For each element of x , compute the cumulative distribution function (CDF) at x of the normal distribution with mean m and variance v .

Default values are $m = 0, v = 1$.

normal_inv (x, m, v) Function File

For each element of x , compute the quantile (the inverse of the CDF) at x of the normal distribution with mean m and variance v .

Default values are $m = 0, v = 1$.

normal_pdf (x, m, v) Function File

For each element of x , compute the probability density function (PDF) at x of the normal distribution with mean m and variance v .

Default values are $m = 0, v = 1$.

normal_rnd (m, v, r, c) Function File

normal_rnd (m, v, sz) Function File

Return an r by c or **size** (sz) matrix of random samples from the normal distribution with parameters m and v . Both m and v must be scalar or of size r by c .

If r and c are omitted, the size of the result matrix is the common size of m and v .

pascal_cdf (x, n, p) Function File

For each element of x , compute the CDF at x of the Pascal (negative binomial) distribution with parameters n and p .

The number of failures in a Bernoulli experiment with success probability p before the n -th success follows this distribution.

pascal_inv (x, n, p) Function File

For each element of x , compute the quantile at x of the Pascal (negative binomial) distribution with parameters n and p .

The number of failures in a Bernoulli experiment with success probability p before the n -th success follows this distribution.

pascal_pdf (x, n, p) Function File

For each element of x , compute the probability density function (PDF) at x of the Pascal (negative binomial) distribution with parameters n and p .

The number of failures in a Bernoulli experiment with success probability p before the n -th success follows this distribution.

- pascal_rnd** (n, p, r, c) Function File
pascal_rnd (n, p, sz) Function File
Return an r by c matrix of random samples from the Pascal (negative binomial) distribution with parameters n and p . Both n and p must be scalar or of size r by c .
If r and c are omitted, the size of the result matrix is the common size of n and p .
Or if sz is a vector, create a matrix of size sz .
- poisson_cdf** ($x, lambda$) Function File
For each element of x , compute the cumulative distribution function (CDF) at x of the Poisson distribution with parameter $lambda$.
- poisson_inv** ($x, lambda$) Function File
For each component of x , compute the quantile (the inverse of the CDF) at x of the Poisson distribution with parameter $lambda$.
- poisson_pdf** ($x, lambda$) Function File
For each element of x , compute the probability density function (PDF) at x of the poisson distribution with parameter $lambda$.
- poisson_rnd** ($lambda, r, c$) Function File
Return an r by c matrix of random samples from the Poisson distribution with parameter $lambda$, which must be a scalar or of size r by c .
If r and c are omitted, the size of the result matrix is the size of $lambda$.
- stdnormal_cdf** (x) Function File
For each component of x , compute the CDF of the standard normal distribution at x .
- stdnormal_inv** (x) Function File
For each component of x , compute compute the quantile (the inverse of the CDF) at x of the standard normal distribution.
- stdnormal_pdf** (x) Function File
For each element of x , compute the probability density function (PDF) of the standard normal distribution at x .
- stdnormal_rnd** (r, c) Function File
stdnormal_rnd (sz) Function File
Return an r by c or **size** (sz) matrix of random numbers from the standard normal distribution.

t_cdf (x, n) Function File
 For each element of x , compute the CDF at x of the t (Student) distribution with n degrees of freedom, i.e., $\text{PROB}(t(n) \leq x)$.

t_inv (x, n) Function File
 For each component of x , compute the quantile (the inverse of the CDF) at x of the t (Student) distribution with parameter n .

t_pdf (x, n) Function File
 For each element of x , compute the probability density function (PDF) at x of the t (Student) distribution with n degrees of freedom.

t_rnd (n, r, c) Function File
t_rnd (n, sz) Function File
 Return an r by c matrix of random samples from the t (Student) distribution with n degrees of freedom. n must be a scalar or of size r by c . Or if sz is a vector create a matrix of size sz .
 If r and c are omitted, the size of the result matrix is the size of n .

uniform_cdf (x, a, b) Function File
 Return the CDF at x of the uniform distribution on $[a, b]$, i.e., $\text{PROB}(\text{uniform}(a, b) \leq x)$.
 Default values are $a = 0, b = 1$.

uniform_inv (x, a, b) Function File
 For each element of x , compute the quantile (the inverse of the CDF) at x of the uniform distribution on $[a, b]$.
 Default values are $a = 0, b = 1$.

uniform_pdf (x, a, b) Function File
 For each element of x , compute the PDF at x of the uniform distribution on $[a, b]$.
 Default values are $a = 0, b = 1$.

uniform_rnd (a, b, r, c) Function File
uniform_rnd (a, b, sz) Function File
 Return an r by c or a **size** (sz) matrix of random samples from the uniform distribution on $[a, b]$. Both a and b must be scalar or of size r by c .
 If r and c are omitted, the size of the result matrix is the common size of a and b .

weibull_cdf (*x*, *alpha*, *sigma*) Function File

Compute the cumulative distribution function (CDF) at *x* of the Weibull distribution with shape parameter *alpha* and scale parameter *sigma*, which is

$$1 - \exp(-(x/\sigma)^\alpha)$$

for $x \geq 0$.

weibull_inv (*x*, *lambda*, *alpha*) Function File

Compute the quantile (the inverse of the CDF) at *x* of the Weibull distribution with shape parameter *alpha* and scale parameter *sigma*.

weibull_pdf (*x*, *alpha*, *sigma*) Function File

Compute the probability density function (PDF) at *x* of the Weibull distribution with shape parameter *alpha* and scale parameter *sigma* which is given by

$$\alpha * \sigma^{-\alpha} * x^{\alpha-1} * \exp(-(x/\sigma)^\alpha)$$

for $x > 0$.

weibull_rnd (*alpha*, *sigma*, *r*, *c*) Function File

weibull_rnd (*alpha*, *sigma*, *sz*) Function File

Return an *r* by *c* matrix of random samples from the Weibull distribution with parameters *alpha* and *sigma* which must be scalar or of size *r* by *c*. Or if *sz* is a vector return a matrix of size *sz*.

If *r* and *c* are omitted, the size of the result matrix is the common size of *alpha* and *sigma*.

wiener_rnd (*t*, *d*, *n*) Function File

Return a simulated realization of the *d*-dimensional Wiener Process on the interval $[0, t]$. If *d* is omitted, $d = 1$ is used. The first column of the return matrix contains time, the remaining columns contain the Wiener process.

The optional parameter *n* gives the number of summands used for simulating the process over an interval of length 1. If *n* is omitted, $n = 1000$ is used.

26 Financial Functions

fv ($r, n, p, l, method$) Function File

Return the future value at the end of period n of an investment which consists of n payments of p in each period, assuming an interest rate r .

The optional argument l may be used to specify an additional lump-sum payment.

The optional argument $method$ may be used to specify whether the payments are made at the end ("e", default) or at the beginning ("b") of each period.

Note that the rate r is specified as a fraction (i.e., 0.05, not 5 percent).

fvl (r, n, l) Function File

Return the future value at the end of n periods of an initial lump sum investment l , given a per-period interest rate r .

Note that the rate r is specified as a fraction (i.e., 0.05, not 5 percent).

irr (p, i) Function File

Return the internal rate of return of a series of payments p from an initial investment i (i.e., the solution of $\text{npv}(r, p) = i$). If the second argument is omitted, a value of 0 is used.

nper ($r, p, a, l, method$) Function File

Return the number of regular payments of p necessary to amortize a loan of amount a and interest r .

The optional argument l may be used to specify an additional lump-sum payment of l made at the end of the amortization time.

The optional argument $method$ may be used to specify whether payments are made at the end ("e", default) or at the beginning ("b") of each period.

Note that the rate r is specified as a fraction (i.e., 0.05, not 5 percent).

npv (r, p, i) Function File

Returns the net present value of a series of irregular (i.e., not necessarily identical) payments p which occur at the ends of n consecutive periods. r specifies the one-period interest rates and can either be a scalar (constant rates) or a vector of the same length as p .

The optional argument i may be used to specify an initial investment.

Note that the rate r is specified as a fraction (i.e., 0.05, not 5 percent).

pmt ($r, n, a, l, method$) Function File

Return the amount of periodic payment necessary to amortize a loan of amount a with interest rate r in n periods.

The optional argument l may be used to specify a terminal lump-sum payment.

The optional argument $method$ may be used to specify whether payments are made at the end ("e", default) or at the beginning ("b") of each period.

pv (*r*, *n*, *p*, *l*, *method*) Function File

Returns the present value of an investment that will pay off *p* for *n* consecutive periods, assuming an interest *r*.

The optional argument *l* may be used to specify an additional lump-sum payment made at the end of *n* periods.

The optional argument *method* may be used to specify whether payments are made at the end ("e", default) or at the beginning ("b") of each period.

Note that the rate *r* is specified as a fraction (i.e., 0.05, not 5 percent).

pvl (*r*, *n*, *p*) Function File

Return the present value of an investment that will pay off *p* in one lump sum at the end of *n* periods, given the interest rate *r*.

Note that the rate *r* is specified as a fraction (i.e., 0.05, not 5 percent).

rate (*n*, *p*, *v*, *l*, *method*) Function File

Return the rate of return on an investment of present value *v* which pays *p* in *n* consecutive periods.

The optional argument *l* may be used to specify an additional lump-sum payment made at the end of *n* periods.

The optional string argument *method* may be used to specify whether payments are made at the end ("e", default) or at the beginning ("b") of each period.

vol (*x*, *m*, *n*) Function File

Return the volatility of each column of the input matrix *x*. The number of data sets per period is given by *m* (e.g. the number of data per year if you want to compute the volatility per year). The optional parameter *n* gives the number of past periods used for computation, if it is omitted, a value of 1 is used. If *t* is the number of rows of *x*, **vol** returns the volatility from **n*m** to *t*.

27 Sets

Octave has a limited set of functions for managing sets of data, where a set is defined as a collection unique elements.

create_set (*x*) Function File

Return a row vector containing the unique values in *x*, sorted in ascending order. For example,

```
create_set ([ 1, 2; 3, 4; 4, 2 ])
⇒ [ 1, 2, 3, 4 ]
```

union (*x*, *y*) Function File

Return the set of elements that are in either of the sets *x* and *y*. For example,

```
union ([ 1, 2, 4 ], [ 2, 3, 5 ])
⇒ [ 1, 2, 3, 4, 5 ]
```

intersection (*x*, *y*) Function File

Return the set of elements that are in both sets *x* and *y*. For example,

```
intersection ([ 1, 2, 3 ], [ 2, 3, 5 ])
⇒ [ 2, 3 ]
```

complement (*x*, *y*) Function File

Return the elements of set *y* that are not in set *x*. For example,

```
complement ([ 1, 2, 3 ], [ 2, 3, 5 ])
⇒ 5
```

28 Polynomial Manipulations

In Octave, a polynomial is represented by its coefficients (arranged in descending order). For example, a vector of length $N + 1$ corresponds to the following polynomial of order N

$$p(x) = c_1x^N + \dots + c_Nx + c_{N+1}.$$

compan (*c*)

Function File

Compute the companion matrix corresponding to polynomial coefficient vector *c*.

The companion matrix is

$$A = \begin{bmatrix} -c_2/c_1 & -c_3/c_1 & \cdots & -c_N/c_1 & -c_{N+1}/c_1 \\ 1 & 0 & \cdots & 0 & 0 \\ 0 & 1 & \cdots & 0 & 0 \\ \vdots & \vdots & \ddots & \vdots & \vdots \\ 0 & 0 & \cdots & 1 & 0 \end{bmatrix}.$$

The eigenvalues of the companion matrix are equal to the roots of the polynomial.

conv (*a*, *b*)

Function File

Convolve two vectors.

`y = conv (a, b)` returns a vector of length equal to `length (a) + length (b) - 1`. If *a* and *b* are polynomial coefficient vectors, `conv` returns the coefficients of the product polynomial.

deconv (*y*, *a*)

Function File

Deconvolve two vectors.

`[b, r] = deconv (y, a)` solves for *b* and *r* such that `y = conv (a, b) + r`.

If *y* and *a* are polynomial coefficient vectors, *b* will contain the coefficients of the polynomial quotient and *r* will be a remainder polynomial of lowest order.

poly (*a*)

Function File

If *a* is a square N -by- N matrix, `poly (a)` is the row vector of the coefficients of `det (z * eye (N) - a)`, the characteristic polynomial of *a*. If *x* is a vector, `poly (x)` is a vector of coefficients of the polynomial whose roots are the elements of *x*.

polyderiv (*c*)

Function File

Return the coefficients of the derivative of the polynomial whose coefficients are given by vector *c*.

[p, s] = polyfit (x, y, n) Function File

Return the coefficients of a polynomial $p(x)$ of degree n that minimizes

$$\sum_{i=1}^N (p(x_i) - y_i)^2$$

to best fit the data in the least squares sense.

The polynomial coefficients are returned in a row vector.

If two output arguments are requested, the second is a structure containing the following fields:

R	The Cholesky factor of the Vandermonde matrix used to compute the polynomial coefficients.
X	The Vandermonde matrix used to compute the polynomial coefficients.
df	The degrees of freedom.
normr	The norm of the residuals.
yf	The values of the polynomial for each value of x .

polyinteg (c) Function File

Return the coefficients of the integral of the polynomial whose coefficients are represented by the vector c .

The constant of integration is set to zero.

polyreduce (c) Function File

Reduces a polynomial coefficient vector to a minimum number of terms by stripping off any leading zeros.

polyval (c, x) Function File

Evaluate a polynomial.

`polyval (c, x)` will evaluate the polynomial at the specified value of x .

If x is a vector or matrix, the polynomial is evaluated at each of the elements of x .

polyvalm (c, x) Function File

Evaluate a polynomial in the matrix sense.

`polyvalm (c, x)` will evaluate the polynomial in the matrix sense, i.e. matrix multiplication is used instead of element by element multiplication as is used in `polyval`.

The argument x must be a square matrix.

residue (*b*, *a*, *tol*)

Function File

If *b* and *a* are vectors of polynomial coefficients, then `residue` calculates the partial fraction expansion corresponding to the ratio of the two polynomials.

The function `residue` returns *r*, *p*, *k*, and *e*, where the vector *r* contains the residue terms, *p* contains the pole values, *k* contains the coefficients of a direct polynomial term (if it exists) and *e* is a vector containing the powers of the denominators in the partial fraction terms.

Assuming *b* and *a* represent polynomials $P(s)$ and $Q(s)$ we have:

$$\frac{P(s)}{Q(s)} = \sum_{m=1}^M \frac{r_m}{(s - p_m)^{e_m}} + \sum_{i=1}^N k_i s^{N-i}.$$

where *M* is the number of poles (the length of the *r*, *p*, and *e* vectors) and *N* is the length of the *k* vector.

The argument *tol* is optional, and if not specified, a default value of 0.001 is assumed. The tolerance value is used to determine whether poles with small imaginary components are declared real. It is also used to determine if two poles are distinct. If the ratio of the imaginary part of a pole to the real part is less than *tol*, the imaginary part is discarded. If two poles are farther apart than *tol* they are distinct. For example,

```

b = [1, 1, 1];
a = [1, -5, 8, -4];
[r, p, k, e] = residue (b, a);
⇒ r = [-2, 7, 3]
⇒ p = [2, 2, 1]
⇒ k = [] (0x0)
⇒ e = [1, 2, 1]

```

which implies the following partial fraction expansion

$$\frac{s^2 + s + 1}{s^3 - 5s^2 + 8s - 4} = \frac{-2}{s - 2} + \frac{7}{(s - 2)^2} + \frac{3}{s - 1}$$

roots (*v*)

Function File

For a vector *v* with *N* components, return the roots of the polynomial

$$v_1 z^{N-1} + \dots + v_{N-1} z + v_N.$$

polyout (*c*, *x*)

Function File

Write formatted polynomial

$$c(x) = c_1 x^n + \dots + c_n x + c_{n+1}$$

and return it as a string or write it to the screen (if *nargout* is zero). *x* defaults to the string "s".

29 Control Theory

The Octave Control Systems Toolbox (OCST) was initially developed by Dr. A. Scottward Hodel a.s.hodel@eng.auburn.edu with the assistance of his students

- R. Bruce Tenison btenison@dibbs.net,
- David C. Clem,
- John E. Ingram John.Ingram@sea.siemans.com, and
- Kristi McGowan.

This development was supported in part by NASA's Marshall Space Flight Center as part of an in-house CACSD environment. Additional important contributions were made by Dr. Kai Mueller mueller@ifr.ing.tu-bs.de and Jose Daniel Munoz Frias (place.m).

An on-line menu-driven tutorial is available via `DEMOcontrol`; beginning OCST users should start with this program.

DEMOcontrol

Function File

Octave Control Systems Toolbox demo/tutorial program. The demo allows the user to select among several categories of OCST function:

```
octave:1> DEMOcontrol
O C T A V E   C O N T R O L   S Y S T E M S   T O O L B O X
Octave Controls System Toolbox Demo

[ 1] System representation
[ 2] Block diagram manipulations
[ 3] Frequency response functions
[ 4] State space analysis functions
[ 5] Root locus functions
[ 6] LQG/H2/Hinfinity functions
[ 7] End
```

Command examples are interactively run for users to observe the use of OCST functions.

29.1 System Data Structure

The OCST stores all dynamic systems in a single data structure format that can represent continuous systems, discrete-systems, and mixed (hybrid) systems in state-space form, and can also represent purely continuous/discrete systems in either transfer function or pole-zero form. In order to provide more flexibility in treatment of discrete/hybrid systems, the OCST also keeps a record of which system outputs are sampled.

Octave structures are accessed with a syntax much like that used by the C programming language. For consistency in use of the data structure used in the OCST, it is recommended that the system structure access m-files be used (see Section 29.2 [sysinterface], page 235). Some elements of the data structure are absent depending on the internal system representation(s) used. More than one system representation can be used for SISO systems; the OCST m-files ensure that all representations used are consistent with one another.

sysrepdemo

Function File

Tutorial for the use of the system data structure functions.

29.1.1 Variables common to all OCST system formats

The data structure elements (and variable types) common to all system representations are listed below; examples of the initialization and use of the system data structures are given in subsequent sections and in the online demo `DEMOcontrol`.

<i>n</i>	
<i>nz</i>	The respective number of continuous and discrete states in the system (scalar)
<i>inname</i>	
<i>outname</i>	list of name(s) of the system input, output signal(s). (list of strings)
<i>sys</i>	System status vector. (vector)
	This vector indicates both what representation was used to initialize the system data structure (called the primary system type) and which other representations are currently up-to-date with the primary system type (see Section 29.2.5 [structaccess], page 241).
	The value of the first element of the vector indicates the primary system type.
0	for tf form (initialized with <code>tf2sys</code> or <code>fir2sys</code>)
1	for zp form (initialized with <code>zp2sys</code>)
2	for ss form (initialized with <code>ss2sys</code>)
	The next three elements are boolean flags that indicate whether tf, zp, or ss, respectively, are “up to date” (whether it is safe to use the variables associated with these representations). These flags are changed when calls are made to the <code>sysupdate</code> command.
<i>tsam</i>	Discrete time sampling period (nonnegative scalar). <i>tsam</i> is set to 0 for continuous time systems.
<i>yd</i>	Discrete-time output list (vector)
	indicates which outputs are discrete time (i.e., produced by D/A converters) and which are continuous time. $yd(ii) = 0$ if output ii is continuous, = 1 if discrete.

The remaining variables of the system data structure are only present if the corresponding entry of the `sys` vector is true (=1).

29.1.2 tf format variables

<i>num</i>	numerator coefficients (vector)
<i>den</i>	denominator coefficients (vector)

29.1.3 zp format variables

<i>zer</i>	system zeros (vector)
<i>pol</i>	system poles (vector)
<i>k</i>	leading coefficient (scalar)

29.1.4 ss format variables

<i>a</i>	
<i>b</i>	
<i>c</i>	
<i>d</i>	The usual state-space matrices. If a system has both continuous and discrete states, they are sorted so that continuous states come first, then discrete states
	Note some functions (e.g., <code>bode</code> , <code>hinfsv</code>) will not accept systems with both discrete and continuous states/outputs
<i>stname</i>	names of system states (list of strings)

29.2 System Construction and Interface Functions

Construction and manipulations of the OCST system data structure (see Section 29.1 [sysstruct], page 233) requires attention to many details in order to ensure that data structure contents remain consistent. Users are strongly encouraged to use the system interface functions in this section. Functions for the formatted display in of system data structures are given in Section 29.3 [sysdisp], page 246.

29.2.1 Finite impulse response system interface functions

fir2sys (*num*, *tsam*, *iname*, *outname*) Function File

construct a system data structure from FIR description

Inputs

num vector of coefficients $[c_0, c_1, \dots, c_n]$ of the SISO FIR transfer function

$$C(z) = c_0 + c_1 z^{-1} + c_2 z^{-2} + \dots + c_n z^{-n}$$

tsam sampling time (default: 1)

iname name of input signal; may be a string or a list with a single entry.

outname name of output signal; may be a string or a list with a single entry.

Output

sys system data structure

Example

```

octave:1> sys = fir2sys([1 -1 2 4],0.342,\
> "A/D input","filter output");
octave:2> sysout(sys)
Input(s)
    1: A/D input

Output(s):
    1: filter output (discrete)

Sampling interval: 0.342
transfer function form:
1*z^3 - 1*z^2 + 2*z^1 + 4
-----
1*z^3 + 0*z^2 + 0*z^1 + 0

```

`[c, tsam, input, output] = sys2fir (sys)` Function File
 Extract FIR data from system data structure; see `fir2sys` for parameter descriptions.

29.2.2 State space system interface functions

`ss (a, b, c, d, tsam, n, nz, stname, inname, outname, outlist)` Function File
 Create system structure from state-space data. May be continuous, discrete, or mixed (sampled data)

Inputs

a
b
c
d usual state space matrices.
 default: *d* = zero matrix

tsam sampling rate. Default: *tsam* = 0 (continuous system)

n
nz number of continuous, discrete states in the system
 If *tsam* is 0, *n* = `rows(a)`, *nz* = 0.
 If *tsam* is greater than zero, *n* = 0, *nz* = `rows(a)`
 see below for system partitioning

stname cell array of strings of state signal names
 default (*stname*=[] on input): `x_n` for continuous states, `xd_n` for discrete states

inname cell array of strings of input signal names
 default (*inname* = [] on input): `u_n`

outname cell array of strings of input signal names
 default (*outname* = [] on input): `y_n`

outlist

list of indices of outputs y that are sampled

If t_{sam} is 0, $outlist = []$.

If t_{sam} is greater than 0, $outlist = 1 : \text{rows}(c)$.

Unlike states, discrete/continuous outputs may appear in any order.

`sys2ss` returns a vector yd where $yd(outlist) = 1$; all other entries of yd are 0.

Outputs $outsys =$ system data structure

System partitioning

Suppose for simplicity that $outlist$ specified that the first several outputs were continuous and the remaining outputs were discrete. Then the system is partitioned as

$$\begin{aligned} x &= \begin{bmatrix} x_c \\ x_d \end{bmatrix} \quad (\begin{matrix} n & \times & 1 \\ n_z & \times & 1 \end{matrix} \text{ discrete states}) \\ a &= \begin{bmatrix} a_{cc} & a_{cd} \\ a_{dc} & a_{dd} \end{bmatrix} \quad b = \begin{bmatrix} b_c \\ b_d \end{bmatrix} \\ c &= \begin{bmatrix} c_{cc} & c_{cd} \\ c_{dc} & c_{dd} \end{bmatrix} \quad d = \begin{bmatrix} d_c \\ d_d \end{bmatrix} \end{aligned}$$

$$(cdc = c(outlist, 1:n), \text{ etc.})$$

with dynamic equations:

$$\begin{aligned} \frac{d}{dt}x_c(t) &= a_{cc}x_c(t) + a_{cd}x_d(k * t_{sam}) + b_c * u(t) \\ x_d((k+1) * t_{sam}) &= a_{dc}x_c(kt_{sam}) + a_{dd}x_d(kt_{sam}) + b_d u(kt_{sam}) \\ y_c(t) &= c_{cc}x_c(t) + c_{cd}x_d(kt_{sam}) + d_c u(t) \\ y_d(kt_{sam}) &= c_{dc}x_c(kt_{sam}) + c_{dd}x_d(kt_{sam}) + d_d u(kt_{sam}) \end{aligned}$$

Signal partitions

	continuous	discrete	
states	stname(1:n,:)	stname((n+1):(n+nz),:)	
outputs	outname(cout,:)	outname(outlist,:)	

where $cout$ is the list of in $1:\text{rows}(p)$ that are not contained in $outlist$. (Discrete/continuous outputs may be entered in any order desired by the user.)

Example

```
octave:1> a = [1 2 3; 4 5 6; 7 8 10];
octave:2> b = [0 0 ; 0 1 ; 1 0];
octave:3> c = eye (3);
octave:4> sys = ss (a, b, c, [], 0, 3, 0, {"volts", "amps", "joules"});
octave:5> sysout(sys);
Input(s)
      1: u_1
```

```

                2: u_2

Output(s):
    1: y_1
    2: y_2
    3: y_3

state-space form:
3 continuous states, 0 discrete states
State(s):
    1: volts
    2: amps
    3: joules

A matrix: 3 x 3
    1  2  3
    4  5  6
    7  8 10
B matrix: 3 x 2
    0  0
    0  1
    1  0
C matrix: 3 x 3
    1  0  0
    0  1  0
    0  0  1
D matrix: 3 x 3
    0  0
    0  0
    0  0

```

Notice that the D matrix is constructed by default to the correct dimensions. Default input and output signals names were assigned since none were given.

```
[a, b, c, d, tsam, n, nz, stname, inname, outname, yd] = sys2ss (sys) Function File
```

Extract state space representation from system data structure.

Input

sys System data structure.

Outputs

a

b

c

d State space matrices for *sys*.

tsam Sampling time of *sys* (0 if continuous).

n
nz Number of continuous, discrete states (discrete states come last in state vector *x*).
stname
iname
outname Signal names (lists of strings); names of states, inputs, and outputs, respectively.
yd Binary vector; *yd(ii)* is 1 if output *y(ii)* is discrete (sampled); otherwise *yd(ii)* is 0.

A warning message is printed if the system is a mixed continuous and discrete system.

Example

```
octave:1> sys=tf2sys([1 2],[3 4 5]);
octave:2> [a,b,c,d] = sys2ss(sys)
a =
    0.00000    1.00000
   -1.66667   -1.33333
b =
    0
    1
c = 0.66667    0.33333
d = 0
```

29.2.3 Transfer function system interface functions

tf2sys (*num*, *den*, *tsam*, *iname*, *outname*)

Function File

Build system data structure from transfer function format data.

Inputs

num
den Coefficients of numerator/denominator polynomials.
tsam Sampling interval; default: 0 (continuous time).
iname
outname Input/output signal names; may be a string or cell array with a single string entry.

Output

sys System data structure.

Example

```
octave:1> sys=tf2sys([2 1],[1 2 1],0.1);
octave:2> sysout(sys)
Input(s)
    1: u_1
Output(s):
    1: y_1 (discrete)
```

```

Sampling interval: 0.1
transfer function form:
2*z^1 + 1
-----
1*z^2 + 2*z^1 + 1

```

`[num, den, tsam, inname, outname] = sys2tf (sys)`

Function File

Extract transfer function data from a system data structure.

See `tf` for parameter descriptions.

Example

```

octave:1> sys=ss([1 -2; -1.1,-2.1],[0;1],[1 1]);
octave:2> [num,den] = sys2tf(sys)
num = 1.0000 -3.0000
den = 1.0000 1.1000 -4.3000

```

29.2.4 Zero-pole system interface functions

`zp2sys (zer, pol, k, tsam, inname, outname)`

Function File

Create system data structure from zero-pole data.

Inputs

zer Vector of system zeros.

pol Vector of system poles.

k Scalar leading coefficient.

tsam Sampling period; default: 0 (continuous system).

inname

outname Input/output signal names (lists of strings).

Output

sys System data structure.

Example

```

octave:1> sys=zp2sys([1 -1],[-2 -2 0],1);
octave:2> sysout(sys)
Input(s)
      1: u_1
Output(s):
      1: y_1
zero-pole form:
1 (s - 1) (s + 1)
-----
s (s + 2) (s + 2)

```

`[zer, pol, k, tsam, inname, outname] = sys2zp (sys)` Function File
 Extract zero/pole/leading coefficient information from a system data structure.

See `zp` for parameter descriptions.

Example

```
octave:1> sys=ss([1 -2; -1.1,-2.1],[0;1],[1 1]);
octave:2> [zer,pol,k] = sys2zp(sys)
zer = 3.0000
pol =
    -2.6953
     1.5953
k = 1
```

29.2.5 Data structure access functions

`syschnames (sys, opt, list, names)` Function File
 Superseded by `syssetsignals`.

`syschtsam (sys, tsam)` Function File
 This function changes the sampling time (`tsam`) of the system. Exits with an error if `sys` is purely continuous time.

`[n, nz, m, p, yd] = sysdimensions (sys, opt)` Function File
 return the number of states, inputs, and/or outputs in the system `sys`.

Inputs

<code>sys</code>	system data structure
<code>opt</code>	String indicating which dimensions are desired. Values:
"all"	(default) return all parameters as specified under Outputs below.
"cst"	return n = number of continuous states
"dst"	return n = number of discrete states
"in"	return n = number of inputs
"out"	return n = number of outputs

Outputs

<code>n</code>	number of continuous states (or individual requested dimension as specified by <code>opt</code>).
<code>nz</code>	number of discrete states
<code>m</code>	number of system inputs
<code>p</code>	number of system outputs
<code>yd</code>	binary vector; $yd(ii)$ is nonzero if output ii is discrete. $yd(ii) = 0$ if output ii is continuous

`[stname, inname, outname, yd] = sysgetsignals (sys)` Function File
`siglist = sysgetsignals (sys, sigid)` Function File
`signame = sysgetsignals (sys, sigid, signalnum, strflag)` Function File

Get signal names from a system

Inputs

sys system data structure for the state space system

sigid signal id. String. Must be one of

- "in" input signals
- "out" output signals
- "st" stage signals
- "yd" value of logical vector *yd*

signalnum index(indices) or name(s) or signals; see `sysidx`

strflag flag to return a string instead of a cell array; Values:

- 0 (default) return a cell array (even if *signalnum* specifies an individual signal)
- 1 return a string. Exits with an error if *signalnum* does not specify an individual signal.

Outputs

- If *sigid* is not specified:

stname
inname
outname signal names (cell array of strings); names of states, inputs, and outputs, respectively.
yd binary vector; *yd(ii)* is nonzero if output *ii* is discrete.

- If *sigid* is specified but *signalnum* is not specified:

`sigid="in"`
siglist is set to the cell array of input names.

`sigid="out"`
siglist is set to the cell array of output names.

`sigid="st"`
siglist is set to the cell array of state names.
stage signals

`sigid="yd"`
siglist is set to logical vector indicating discrete outputs;
siglist(ii) = 0 indicates that output *ii* is continuous (unsampled), otherwise it is discrete.

- If the first three input arguments are specified:

signame is a cell array of the specified signal names (*sigid* is "in", "out", or "st"), or else the logical flag indicating whether output(s) *signalnum* is(are) discrete (*sigval*=1) or continuous (*sigval*=0).

Examples (From sysrepdemo)

```

octave> sys=ss(rand(4),rand(4,2),rand(3,4));
octave># get all signal names
octave> [Ast,Ain,Aout,Ayd] = sysgetsignals(sys)
Ast =
(
  [1] = x_1
  [2] = x_2
  [3] = x_3
  [4] = x_4
)
Ain =
(
  [1] = u_1
  [2] = u_2
)
Aout =
(
  [1] = y_1
  [2] = y_2
  [3] = y_3
)
Ayd =
0 0 0
octave> # get only input signal names:
octave> Ain = sysgetsignals(sys,"in")
Ain =
(
  [1] = u_1
  [2] = u_2
)
octave> # get name of output 2 (in cell array):
octave> Aout = sysgetsignals(sys,"out",2)
Aout =
(
  [1] = y_2
)
octave> # get name of output 2 (as string):
octave> Aout = sysgetsignals(sys,"out",2,1)
Aout = y_2

```

sysgettype (sys)

return the initial system type of the system

Input

sys System data structure.

Output

Function File

systype String indicating how the structure was initially constructed. Values: "ss", "zp", or "tf".

FIR initialized systems return `systype="tf"`.

syssetsignals (*sys*, *opt*, *names*, *sig_idx*) Function File
change the names of selected inputs, outputs and states.

Inputs

sys System data structure.

opt Change default name (output).

"out" Change selected output names.

"in" Change selected input names.

"st" Change selected state names.

"yd" Change selected outputs from discrete to continuous or from continuous to discrete.

names

`opt = "out", "in", "st"`
string or string array containing desired signal names or values.

`opt = "yd"`
To desired output continuous/discrete flag. Set name to 0 for continuous, or 1 for discrete.

sig_idx indices or names of outputs, yd, inputs, or states whose respective names/values should be changed.

Default: replace entire cell array of names/entire yd vector.

Outputs

retsys *sys* with appropriate signal names changed (or *yd* values, where appropriate).

Example

```
octave:1> sys=ss([1 2; 3 4],[5;6],[7 8]);
octave:2> sys = syssetsignals(sys,"st",str2mat("Posx","Velx"));
octave:3> sysout(sys)
Input(s)
    1: u_1
Output(s):
    1: y_1
state-space form:
2 continuous states, 0 discrete states
State(s):
    1: Posx
    2: Velx
```

```

A matrix: 2 x 2
 1  2
 3  4
B matrix: 2 x 1
 5
 6
C matrix: 1 x 2
 7  8
D matrix: 1 x 1
 0

```

sysupdate (*sys*, *opt*) Function File

Update the internal representation of a system.

Inputs

sys: system data structure

opt string:

- "tf" update transfer function form
- "zp" update zero-pole form
- "ss" update state space form
- "all" all of the above

Outputs

retsys Contains union of data in *sys* and requested data. If requested data in *sys* is already up to date then *retsys=sys*.

Conversion to **tf** or **zp** exits with an error if the system is mixed continuous/digital.

[*systype*, *nout*, *nin*, *ncstates*, *ndstates*] = **minfo** (*inmat*) Function File

Determines the type of system matrix. *inmat* can be a varying, a system, a constant, and an empty matrix.

Outputs

systype Can be one of: varying, system, constant, and empty.

nout The number of outputs of the system.

nin The number of inputs of the system.

ncstates The number of continuous states of the system.

ndstates The number of discrete states of the system.

sysgettsam (*sys*) Function File

Return the sampling time of the system *sys*.

29.2.6 Data structure internal functions

29.3 System display functions

sysout (*sys*, *opt*) Function File

print out a system data structure in desired format

sys system data structure

opt Display option

 [] primary system form (default)

 "ss" state space form

 "tf" transfer function form

 "zp" zero-pole form

 "all" all of the above

tfout (*num*, *denom*, *x*) Function File

Print formatted transfer function $n(s)/d(s)$ to the screen. *x* defaults to the string "s"

zpout (*zer*, *pol*, *k*, *x*) Function File

print formatted zero-pole form to the screen. *x* defaults to the string "s"

29.4 Block Diagram Manipulations

See Section 29.7 [systeme], page 264.

Unless otherwise noted, all parameters (input,output) are system data structures.

bddemo (*inputs*) Function File

Octave Controls toolbox demo: Block Diagram Manipulations demo.

buildssic (*clst*, *ulst*, *olst*, *ilst*, *s1*, *s2*, *s3*, *s4*, *s5*, *s6*, *s7*, *s8*) Function File

Form an arbitrary complex (open or closed loop) system in state-space form from several systems. **buildssic** can easily (despite its cryptic syntax) integrate transfer functions from a complex block diagram into a single system with one call. This function is especially useful for building open loop interconnections for \mathcal{H}_∞ and \mathcal{H}_2 designs or for closing loops with these controllers.

Although this function is general purpose, the use of **sysgroup** **sysmult**, **sysconnect** and the like is recommended for standard operations since they can handle mixed discrete and continuous systems and also the names of inputs, outputs, and states.

The parameters consist of 4 lists that describe the connections outputs and inputs and up to 8 systems *s1*–*s8*. Format of the lists:

- clst* connection list, describes the input signal of each system. The maximum number of rows of *Clst* is equal to the sum of all inputs of *s1-s8*.
Example: $[1 \ 2 \ -1; \ 2 \ 1 \ 0]$ means that: new input 1 is old input 1 + output 2 - output 1, and new input 2 is old input 2 + output 1. The order of rows is arbitrary.
- ulst* if not empty the old inputs in vector *ulst* will be appended to the outputs. You need this if you want to “pull out” the input of a system. Elements are input numbers of *s1-s8*.
- olst* output list, specify the outputs of the resulting systems. Elements are output numbers of *s1-s8*. The numbers are allowed to be negative and may appear in any order. An empty matrix means all outputs.
- ilst* input list, specify the inputs of the resulting systems. Elements are input numbers of *s1-s8*. The numbers are allowed to be negative and may appear in any order. An empty matrix means all inputs.

Example: Very simple closed loop system.

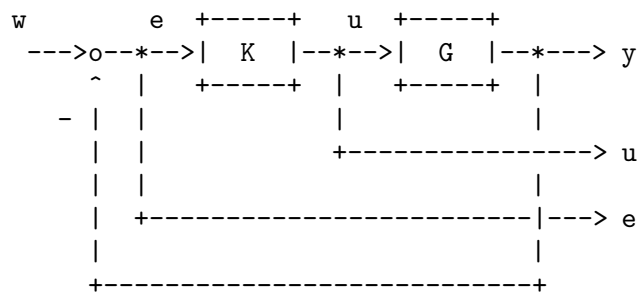

The closed loop system *GW* can be obtained by

```
GW = buildssic([1 2; 2 -1], 2, [1 2 3], 2, G, K);
```

- clst* 1st row: connect input 1 (*G*) with output 2 (*K*).
2nd row: connect input 2 (*K*) with negative output 1 (*G*).
- ulst* Append input of 2 (*K*) to the number of outputs.
- olst* Outputs are output of 1 (*G*), 2 (*K*) and appended output 3 (from *ulst*).
- ilst* The only input is 2 (*K*).

Here is a real example:

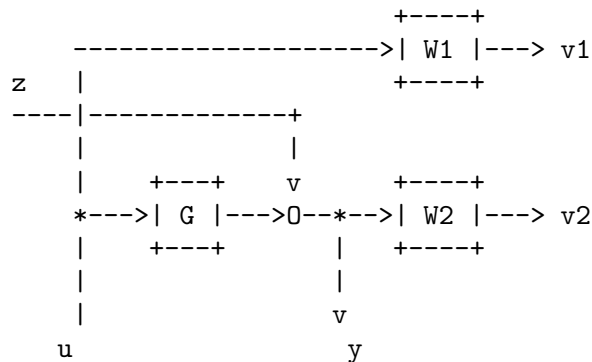

$$\min \|GW_{vz}\|_{\infty}$$

The closed loop system GW from $[z, u]^T$ to $[v_1, v_2, y]^T$ can be obtained by (all SISO systems):

```
GW = buildssic([1, 4; 2, 4; 3, 1], 3, [2, 3, 5],
               [3, 4], G, W1, W2, One);
```

where “One” is a unity gain (auxillary) function with order 0. (e.g. `One = ugain(1);`)

sys = jet707 () Function File
 Creates a linearized state-space model of a Boeing 707-321 aircraft at $v=80$ m/s ($M = 0.26$, $G_{a0} = -3^\circ$, $\alpha_0 = 4^\circ$, $\kappa = 50^\circ$).
 System inputs: (1) thrust and (2) elevator angle.
 System outputs: (1) airspeed and (2) pitch angle.
Reference: R. Brockhaus: *Flugregelung* (Flight Control), Springer, 1994.

ord2 (nfreq, damp, gain) Function File
 Creates a continuous 2nd order system with parameters:
Inputs
nfreq natural frequency [Hz]. (not in rad/s)
damp damping coefficient
gain dc-gain This is steady state value only for $damp > 0$. gain is assumed to be 1.0 if omitted.

Output

outsys system data structure has representation with $w = 2\pi f$:

$$G = \begin{bmatrix} / & & & & \backslash \\ | & / & -2w*damp & -w & \backslash & / & w & \backslash & | \\ | & | & & & | & | & | & | & [0 & gain], 0 & | \\ | & \backslash & w & & 0 & / & \backslash & 0 & / & | \\ \backslash & & & & & & & & & / \end{bmatrix}$$

See also `jet707` (MIMO example, Boeing 707-321 aircraft model)

sysadd (gsys, hsys) Function File
 returns `sys = gsys + hsys`.

- Exits with an error if *gsys* and *hsys* are not compatibly dimensioned.
- Prints a warning message if system states have identical names; duplicate names are given a suffix to make them unique.
- *sys* input/output names are taken from *gsys*.

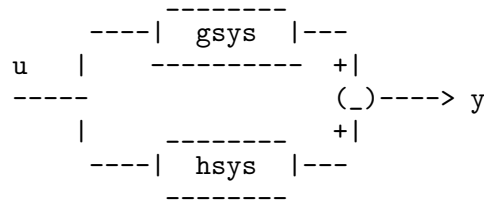

`sys = sysappend (syst, b, c, d, outname, inname, yd)`
 appends new inputs and/or outputs to a system

Function File

Inputs

syst system data structure
b matrix to be appended to sys "B" matrix (empty if none)
c matrix to be appended to sys "C" matrix (empty if none)
d revised sys d matrix (can be passed as [] if the revised d is all zeros)
outname list of names for new outputs
inname list of names for new inputs
yd binary vector; $yd(ii) = 0$ indicates a continuous output; $yd(ii) = 1$ indicates a discrete output.

Outputs

sys

```

sys.b := [syst.b , b]
sys.c := [syst.c ]
        [ c      ]
sys.d := [syst.d | D12 ]
        [ D21   | D22 ]
  
```

where $D12$, $D21$, and $D22$ are the appropriate dimensioned blocks of the input parameter d .

- The leading block $D11$ of d is ignored.
- If *inname* and *outname* are not given as arguments, the new inputs and outputs are be assigned default names.
- *yd* is a binary vector of length `rows(c)` that indicates continuous/sampled outputs. Default value for *yd* is:
 - *sys* is continuous or mixed $yd = \mathbf{zeros}(1, \mathbf{rows}(c))$
 - *sys* is discrete $yd = \mathbf{ones}(1, \mathbf{rows}(c))$

`clsys = sysconnect (sys, out_idx, in_idx, order, tol)`
 Close the loop from specified outputs to respective specified inputs

Function File

Inputs

sys System data structure.

out_idx
in_idx Names or indices of signals to connect (see `sysidx`). The output specified by *out_idx*(*ii*) is connected to the input specified by *in_idx*(*ii*).

order logical flag (default = 0)

0 Leave inputs and outputs in their original order.

1 Permute inputs and outputs to the order shown in the diagram below.

tol Tolerance for singularities in algebraic loops, default: 200eps.

Outputs

clsys Resulting closed loop system.

Method

`sysconnect` internally permutes selected inputs, outputs as shown below, closes the loop, and then permutes inputs and outputs back to their original order

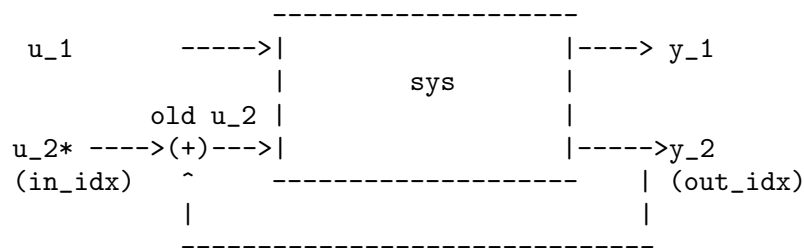

The input that has the summing junction added to it has an * added to the end of the input name.

`[csys, acd, ccd] = syscont (sys)` Function File

Extract the purely continuous subsystem of an input system.

Input

sys system data structure.

Outputs

csys is the purely continuous input/output connections of *sys*

acd

ccd connections from discrete states to continuous states, discrete states to continuous outputs, respectively.

returns *csys* empty if no continuous/continuous path exists

`[dsys, adc, cdc] = sysdisc (sys)` Function File

Input

sys System data structure.

Outputs

dsys Purely discrete portion of *sys* (returned empty if there is no purely discrete path from inputs to outputs).

adc

cdc Connections from continuous states to discrete states and discrete. outputs, respectively.

retsys = **sysdup** (*asys*, *out_idx*, *in_idx*) Function File

Duplicate specified input/output connections of a system

Inputs

asys system data structure

out_idx

in_idx indices or names of desired signals (see **sigidx**). duplicates are made of *y(out_idx(ii))* and *u(in_idx(ii))*.

Output

retsys Resulting closed loop system: duplicated i/o names are appended with a "+" suffix.

Method

sysdup creates copies of selected inputs and outputs as shown below. *u1*, *y1* is the set of original inputs/outputs, and *u2*, *y2* is the set of duplicated inputs/outputs in the order specified in *in_idx*, *out_idx*, respectively

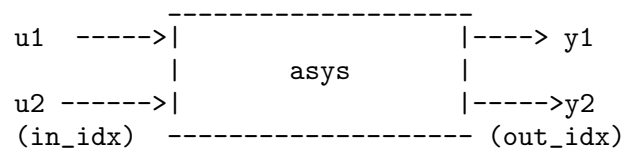

sys = **sysgroup** (*asys*, *bsys*) Function File

Combines two systems into a single system.

Inputs

asys

bsys System data structures.

Output

sys *sys* = **blockdiag**(*asys*, *bsys*)

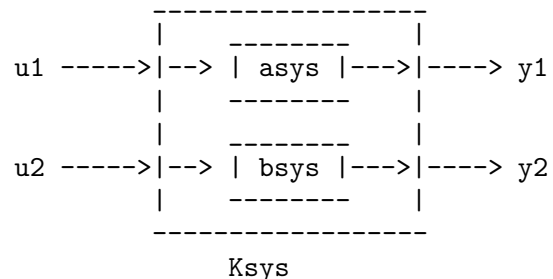

The function also rearranges the internal state-space realization of *sys* so that the continuous states come first and the discrete states come last. If there are duplicate names, the second name has a unique suffix appended on to the end of the name.

sys = **sysmult** (*Asys*, *Bsys*) Function File
 Compute $sys = Asys * Bsys$ (series connection):

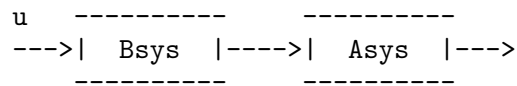

A warning occurs if there is direct feed-through from an input or a continuous state of *Bsys*, through a discrete output of *Bsys*, to a continuous state or output in *Asys* (system data structure does not recognize discrete inputs).

retsys = **sysprune** (*asys*, *out_idx*, *in_idx*) Function File
 Extract specified inputs/outputs from a system

Inputs

asys system data structure

out_idx

in_idx Indices or signal names of the outputs and inputs to be kept in the returned system; remaining connections are “pruned” off. May select as [] (empty matrix) to specify all outputs/inputs.

```

      retsys = sysprune (Asys, [1:3,4], "u_1");
      retsys = sysprune (Asys, {"tx", "ty", "tz"}, 4);
  
```

Output

retsys Resulting system.



pv = **sysreorder** (*vlen*, *list*) Function File

Inputs

vlen Vector length.

list A subset of [1:*vlen*].

Output

pv A permutation vector to order elements of [1:*vlen*] in *list* to the end of a vector.

Used internally by **sysconnect** to permute vector elements to their desired locations.

retsys = sysscale (*sys*, *outscale*, *inscale*, *outname*, *iname*) Function File
 scale inputs/outputs of a system.

Inputs

sys Structured system.
outscale
inscale Constant matrices of appropriate dimension.
outname
iname Lists of strings with the names of respectively outputs and inputs.

Output

retsys resulting open loop system:

```

      -----
u --->| inscale |--->| sys |--->| outscale |---> y
      -----
  
```

If the input names and output names (each a list of strings) are not given and the scaling matrices are not square, then default names will be given to the inputs and/or outputs.

A warning message is printed if *outscale* attempts to add continuous system outputs to discrete system outputs; otherwise *yd* is set appropriately in the returned value of *sys*.

sys = syssub (*Gsys*, *Hsys*) Function File
 Return $sys = Gsys - Hsys$.

Method

Gsys and *Hsys* are connected in parallel. The input vector is connected to both systems; the outputs are subtracted. Returned system names are those of *Gsys*.

```

      +-----+
+---->|  Gsys  |----+
|      +-----+  |
|                      +|
u ---+                      ( )--> y
|                      -|
|      +-----+  |
+---->|  Hsys  |----+
      +-----+
  
```

ugain (*n*) Function File

Creates a system with unity gain, no states. This trivial system is sometimes needed to create arbitrary complex systems from simple systems with **buildssic**. Watch out if you are forming sampled systems since **ugain** does not contain a sampling period.

$W = \mathbf{wgt1o}(vl, vh, fc)$ Function File

State space description of a first order weighting function.

Weighting function are needed by the $\mathcal{H}_2/\mathcal{H}_\infty$ design procedure. These function are part of the augmented plant P (see `hinfdemo` for an application example).

Inputs

vl Gain at low frequencies.
 vh Gain at high frequencies.
 fc Corner frequency (in Hz, **not** in rad/sec)

Output

W Weighting function, given in form of a system data structure.

$ksys = \mathbf{parallel}(asys, bsys)$ Function File

Forms the parallel connection of two systems.

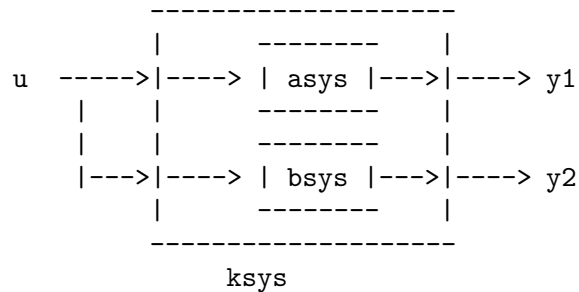

$[retsys, nc, no] = \mathbf{sysmin}(sys, flg)$ Function File

Returns a minimal (or reduced order) system

Inputs

sys System data structure
 flg When equal to 0 (default value), returns minimal system, in which state names are lost; when equal to 1, returns system with physical states removed that are either uncontrollable or unobservable (cannot reduce further without discarding physical meaning of states).

Outputs

$retsys$ Returned system.
 nc Number of controllable states in the returned system.
 no Number of observable states in the returned system.
 $cflg$ `is_controllable(retsys)`.
 $offg$ `is_observable(retsys)`.

29.5 Numerical Functions

$x = \mathbf{are}(a, b, c, opt)$ Function File

Solve the Algebraic Riccati Equation

$$A^T X + XA - XBX + C = 0$$

Inputs for identically dimensioned square matrices

- a n by n matrix;
- b n by n matrix or n by m matrix; in the latter case b is replaced by $b := b * b'$;
- c n by n matrix or p by m matrix; in the latter case c is replaced by $c := c' * c$;
- opt (optional argument; default = "B"): String option passed to **balance** prior to ordered Schur decomposition.

Output

x solution of the ARE.

Method Laub's Schur method (IEEE Transactions on Automatic Control, 1979) is applied to the appropriate Hamiltonian matrix.

$x = \mathbf{dare}(a, b, q, r, opt)$ Function File

Return the solution, x of the discrete-time algebraic Riccati equation

$$A^T X A - X + A^T X B (R + B^T X B)^{-1} B^T X A + Q = 0$$

Inputs

- a n by n matrix;
- b n by m matrix;
- q n by n matrix, symmetric positive semidefinite, or a p by n matrix, In the latter case $q := q' * q$ is used;
- r m by m , symmetric positive definite (invertible);
- opt (optional argument; default = "B"): String option passed to **balance** prior to ordered QZ decomposition.

Output

x solution of DARE.

Method Generalized eigenvalue approach (Van Dooren; SIAM J. Sci. Stat. Comput., Vol 2) applied to the appropriate symplectic pencil.

See also: Ran and Rodman, *Stable Hermitian Solutions of Discrete Algebraic Riccati Equations*, Mathematics of Control, Signals and Systems, Vol 5, no 2 (1992), pp 165–194.

[tvals, plist] = dre (sys, q, r, qf, t0, tf, ptol, maxits)

Function File

Solve the differential Riccati equation

$$-\frac{dP}{dt} = A^T P + PA - PBR^{-1}B^T P + Q$$

$$P(t_f) = Q_f$$

for the LTI system sys. Solution of standard LTI state feedback optimization

$$\min \int_{t_0}^{t_f} x^T Q x + u^T R u dt + x(t_f)^T Q_f x(t_f)$$

optimal input is

$$u = -R^{-1}B^T P(t)x$$

Inputs

sys continuous time system data structure
q state integral penalty
r input integral penalty
qf state terminal penalty
t0
tf limits on the integral
ptol tolerance (used to select time samples; see below); default = 0.1
maxits number of refinement iterations (default=10)

Outputs

tvals time values at which $p(t)$ is computed
plist list values of $p(t)$; *plist* { *i* } is $p(tvals(i))$

tvals is selected so that:

$$\|plist_i - plist_{i-1}\| < ptol$$

for every *i* between 2 and length(*tvals*).

dgram (*a*, *b*)

Function File

Return controllability gramian of discrete time system

$$x_{k+1} = ax_k + bu_k$$

Inputs

a *n* by *n* matrix
b *n* by *m* matrix

Output

m *n* by *n* matrix, satisfies

$$ama^T - m + bb^T = 0$$

dlyap (*a*, *b*) Function File

Solve the discrete-time Lyapunov equation

Inputs

a *n* by *n* matrix;

b Matrix: *n* by *n*, *n* by *m*, or *p* by *n*.

Output

x matrix satisfying appropriate discrete time Lyapunov equation.

Options:

- *b* is square: solve

$$axa^T - x + b = 0$$

- *b* is not square: *x* satisfies either

$$axa^T - x + bb^T = 0$$

or

$$a^Txa - x + b^Tb = 0,$$

whichever is appropriate.

Method Uses Schur decomposition method as in Kitagawa, *An Algorithm for Solving the Matrix Equation $X = FXF' + S$* , International Journal of Control, Volume 25, Number 5, pages 745–753 (1977).

Column-by-column solution method as suggested in Hammarling, *Numerical Solution of the Stable, Non-Negative Definite Lyapunov Equation*, IMA Journal of Numerical Analysis, Volume 2, pages 303–323 (1982).

gram (*a*, *b*) Function File

Return controllability gramian *m* of the continuous time system $dx/dt = ax + bu$.

m satisfies $am + ma' + bb' = 0$.

lyap (*a*, *b*, *c*) Function File

lyap (*a*, *b*) Function File

Solve the Lyapunov (or Sylvester) equation via the Bartels-Stewart algorithm (Communications of the ACM, 1972).

If *a*, *b*, and *c* are specified, then **lyap** returns the solution of the Sylvester equation

$$AX + XB + C = 0$$

If only (**a**, **b**) are specified, then **lyap** returns the solution of the Lyapunov equation

$$A^T X + XA + B = 0$$

If *b* is not square, then **lyap** returns the solution of either

$$A^T X + XA + B^T B = 0$$

or

$$AX + XA^T + BB^T = 0$$

whichever is appropriate.

Solves by using the Bartels-Stewart algorithm (1972).

qzval (*a*, *b*) Function File

Compute generalized eigenvalues of the matrix pencil $(A - \lambda B)$.

a and *b* must be real matrices.

`qzval` is obsolete; use `qz` instead.

$y = \mathbf{zgfmul}$ (*a*, *b*, *c*, *d*, *x*) Function File

Compute product of `zgep` incidence matrix *F* with vector *x*. Used by `zgepbal` (in `zgsca1`) as part of generalized conjugate gradient iteration.

zgfslv (*n*, *m*, *p*, *b*) Function File

Solve system of equations for dense `zgep` problem.

$zz = \mathbf{zginit}$ (*a*, *b*, *c*, *d*) Function File

Construct right hand side vector *zz* for the zero-computation generalized eigenvalue problem balancing procedure. Called by `zgepbal`.

zgreduce (*sys*, *meps*) Function File

Implementation of procedure REDUCE in (Emami-Naeini and Van Dooren, *Automatica*, # 1982).

$[nonz, zer] = \mathbf{zgrownorm}$ (*mat*, *meps*) Function File

Return *nonz* = number of rows of *mat* whose two norm exceeds *meps*, and *zer* = number of rows of *mat* whose two norm is less than *meps*.

$x = \mathbf{zgscal}$ (*f*, *z*, *n*, *m*, *p*) Function File

Generalized conjugate gradient iteration to solve zero-computation generalized eigenvalue problem balancing equation $fx = z$; called by `zgepbal`.

$[a, b] = \mathbf{zgsgiv}$ (*c*, *s*, *a*, *b*) Function File

Apply givens rotation *c,s* to row vectors *a*, *b*. No longer used in zero-balancing (`_zgpbal_`); kept for backward compatibility.

$x = \mathbf{zgshsr}$ (*y*) Function File

Apply householder vector based on e^m to column vector *y*. Called by `zgfslv`.

References

ZGEP Hodel, *Computation of Zeros with Balancing*, 1992, Linear Algebra and its Applications

Generalized CG

Golub and Van Loan, *Matrix Computations*, 2nd ed 1989.

29.6 System Analysis-Properties

analdemo () Function File
 Octave Controls toolbox demo: State Space analysis demo

$[n, m, p] = \mathbf{abcddim}(a, b, c, d)$ Function File
 Check for compatibility of the dimensions of the matrices defining the linear system $[A, B, C, D]$ corresponding to

$$\begin{aligned}\frac{dx}{dt} &= Ax + Bu \\ y &= Cx + Du\end{aligned}$$

or a similar discrete-time system.

If the matrices are compatibly dimensioned, then **abcddim** returns

n The number of system states.
 m The number of system inputs.
 p The number of system outputs.

Otherwise **abcddim** returns $n = m = p = -1$.

Note: $n = 0$ (pure gain block) is returned without warning.

ctrb (*sys*, *b*) Function File
ctrb (*a*, *b*) Function File
 Build controllability matrix:

$$Q_s = [BABA^2B \dots A^{n-1}B]$$

of a system data structure or the pair (a, b) .

ctrb forms the controllability matrix. The numerical properties of **is_controllable** are much better for controllability tests.

h2norm (*sys*) Function File
 Computes the \mathcal{H}_2 norm of a system data structure (continuous time only).
 Reference: Doyle, Glover, Khargonekar, Francis, *State-Space Solutions to Standard \mathcal{H}_2 and \mathcal{H}_∞ Control Problems*, IEEE TAC August 1989.

$[g, gmin, gmax] = \mathbf{hinfnorm}(sys, tol, gmin, gmax, ptol)$ Function File
 Computes the \mathcal{H}_∞ norm of a system data structure.

Inputs

sys system data structure
tol \mathcal{H}_∞ norm search tolerance (default: 0.001)

gmin minimum value for norm search (default: 1e-9)
gmax maximum value for norm search (default: 1e+9)
ptol pole tolerance:

- if *sys* is continuous, poles with $|\text{real}(\text{pole})| < \text{ptol}\|H\|$ (H is appropriate Hamiltonian) are considered to be on the imaginary axis.
- if *sys* is discrete, poles with $|\text{pole} - 1| < \text{ptol}\|[s_1 s_2]\|$ (appropriate symplectic pencil) are considered to be on the unit circle.
- Default value: 1e-9

Outputs

g Computed gain, within *tol* of actual gain. *g* is returned as Inf if the system is unstable.

gmin
gmax Actual system gain lies in the interval [*gmin*, *gmax*].

References: Doyle, Glover, Khargonekar, Francis, *State-space solutions to standard \mathcal{H}_2 and \mathcal{H}_∞ control problems*, IEEE TAC August 1989; Iglesias and Glover, *State-Space approach to discrete-time \mathcal{H}_∞ control*, Int. J. Control, vol 54, no. 5, 1991; Zhou, Doyle, Glover, *Robust and Optimal Control*, Prentice-Hall, 1996.

obsv (*sys*, *c*) Function File
obsv (*a*, *c*) Function File
 Build observability matrix:

$$Q_b = \begin{bmatrix} C \\ CA \\ CA^2 \\ \vdots \\ CA^{n-1} \end{bmatrix}$$

of a system data structure or the pair (*a*, *c*).

The numerical properties of **is_observable** are much better for observability tests.

[zer, pol] = pzmap (*sys*) Function File
 Plots the zeros and poles of a system in the complex plane.

Input

sys System data structure.

Outputs

pol
zer if omitted, the poles and zeros are plotted on the screen. otherwise, *pol* and *zer* are returned as the system poles and zeros (see **sys2zp** for a preferable function call).

$retval = \mathbf{is_abcd} (a, b, c, d)$ Function File
 Returns $retval = 1$ if the dimensions of a, b, c, d are compatible, otherwise $retval = 0$ with an appropriate diagnostic message printed to the screen. The matrices $b, c,$ or d may be omitted.

$[retval, u] = \mathbf{is_controllable} (sys, tol)$ Function File
 $[retval, u] = \mathbf{is_controllable} (a, b, tol)$ Function File
 Logical check for system controllability.

Inputs

sys system data structure
 a
 b n by n, n by m matrices, respectively
 tol optional roundoff paramter. default value: $10*\epsilon$

Outputs

$retval$ Logical flag; returns true (1) if the system sys or the pair (a, b) is controllable, whichever was passed as input arguments.
 u u is an orthogonal basis of the controllable subspace.

Method Controllability is determined by applying Arnoldi iteration with complete re-orthogonalization to obtain an orthogonal basis of the Krylov subspace

$$\text{span} ([b, a*b, \dots, a^{n-1}*b]).$$

The Arnoldi iteration is executed with `krylov` if the system has a single input; otherwise a block Arnoldi iteration is performed with `krylovb`.

$retval = \mathbf{is_detectable} (a, c, tol, dflg)$ Function File
 $retval = \mathbf{is_detectable} (sys, tol)$ Function File

Test for detectability (observability of unstable modes) of (a, c) .

Returns 1 if the system a or the pair (a, c) is detectable, 0 if not, and -1 if the system has unobservable modes at the imaginary axis (unit circle for discrete-time systems).

See `is_stabilizable` for detailed description of arguments and computational method.

$[retval, dgkf_struct] = \mathbf{is_dgkf} (asys, nu, ny, tol)$ Function File

Determine whether a continuous time state space system meets assumptions of DGKF algorithm. Partitions system into:

$$\begin{bmatrix} dx/dt \\ z \\ y \end{bmatrix} = \begin{bmatrix} A & | & Bw & Bu \\ \hline Cz & | & Dzw & Dzu \\ Cy & | & Dyw & Dyu \end{bmatrix} \begin{bmatrix} w \\ u \end{bmatrix}$$

or similar discrete-time system. If necessary, orthogonal transformations qw, qz and nonsingular transformations ru, ry are applied to respective vectors w, z, u, y in order to satisfy DGKF assumptions. Loop shifting is used if dyu block is nonzero.

Inputs

asys system data structure
nu number of controlled inputs
ny number of measured outputs
tol threshold for 0; default: 200*`eps`.

Outputs

retval true(1) if system passes check, false(0) otherwise

dgkf_struct

data structure of `is_dgkf` results. Entries:

nw

nz dimensions of w, z

a system A matrix

bw $(n \times nw)$ qw -transformed disturbance input matrix

bu $(n \times nu)$ ru -transformed controlled input matrix;
 $B = [BwBu]$

cz $(nz \times n)$ Qz -transformed error output matrix

cy $(ny \times n)$ ry -transformed measured output matrix
 $C = [Cz; Cy]$

dzu

dyw off-diagonal blocks of transformed system D matrix that enter z, y from u, w respectively

ru controlled input transformation matrix

ry observed output transformation matrix

dyu_nz nonzero if the dyu block is nonzero.

dyu untransformed dyu block

dflg nonzero if the system is discrete-time

`is_dgkf` exits with an error if the system is mixed discrete/continuous.

References

- [1] Doyle, Glover, Khargonekar, Francis, *State Space Solutions to Standard \mathcal{H}_2 and \mathcal{H}_∞ Control Problems*, IEEE TAC August 1989.
- [2] Maciejowski, J.M., *Multivariable Feedback Design*, Addison-Wesley, 1989.

`digital = is_digital (sys, eflg)`
 Return nonzero if system is digital.

Function File

Inputs

sys System data structure.

eflg When equal to 0 (default value), exits with an error if the system is mixed (continuous and discrete components); when equal to 1, print a warning if the system is mixed (continuous and discrete); when equal to 2, operate silently.

Output

digital When equal to 0, the system is purely continuous; when equal to 1, the system is purely discrete; when equal to -1, the system is mixed continuous and discrete.

Exits with an error if *sys* is a mixed (continuous and discrete) system.

$[retval, u] = \mathbf{is_observable}(a, c, tol)$ Function File
 $[retval, u] = \mathbf{is_observable}(sys, tol)$ Function File

Logical check for system observability.

Default: $tol = tol = 10 * \text{norm}(a, 'fro') * \text{eps}$

Returns 1 if the system *sys* or the pair (*a*, *c*) is observable, 0 if not.

See `is_controllable` for detailed description of arguments and default values.

is_sample (*ts*) Function File

Return true if *ts* is a valid sampling time (real, scalar, > 0).

is_asiso (*sys*) Function File

Returns nonzero if the system data structure *sys* is single-input, single-output.

$retval = \mathbf{is_stabilizable}(sys, tol)$ Function File

$retval = \mathbf{is_stabilizable}(a, b, tol, dflg)$ Function File

Logical check for system stabilizability (i.e., all unstable modes are controllable).

Returns 1 if the system is stabilizable, 0 if the the system is not stabilizable, -1 if the system has non stabilizable modes at the imaginary axis (unit circle for discrete-time systems).

Test for stabilizability is performed via Hautus Lemma. If *dflg*≠0 assume that discrete-time matrices (a,b) are supplied.

is_signal_list (*mylist*) Function File

Return true if *mylist* is a list of individual strings.

is_stable (*a*, *tol*, *dflg*) Function File

is_stable (*sys*, *tol*) Function File

Returns 1 if the matrix *a* or the system *sys* is stable, or 0 if not.

Inputs

tol is a roundoff parameter, set to $200*\mathbf{eps}$ if omitted.

dflg Digital system flag (not required for system data structure):

dflg != 0 stable if eig(a) is in the unit circle

dflg == 0 stable if eig(a) is in the open LHP (default)

29.7 System Analysis-Time Domain

c2d (*sys*, *opt*, *t*) Function File

c2d (*sys*, *t*) Function File

Converts the system data structure describing:

$$\dot{x} = A_c x + B_c u$$

into a discrete time equivalent model:

$$x_{n+1} = A_d x_n + B_d u_n$$

via the matrix exponential or bilinear transform.

Inputs

sys system data structure (may have both continuous time and discrete time subsystems)

opt string argument; conversion option (optional argument; may be omitted as shown above)

"ex" use the matrix exponential (default)

"bi" use the bilinear transformation

$$s = \frac{2(z-1)}{T(z+1)}$$

FIXME: This option exits with an error if *sys* is not purely continuous. (The **ex** option can handle mixed systems.)

"matched"

Use the matched pole/zero equivalent transformation (currently only works for purely continuous SISO systems).

t sampling time; required if *sys* is purely continuous.

Note: if the second argument is not a string, **c2d**() assumes that the second argument is *t* and performs appropriate argument checks.

Output

dsys Discrete time equivalent via zero-order hold, sample each *t* sec.

This function adds the suffix **_d** to the names of the new discrete states.

d2c (*sys*, *tol*) Function File
d2c (*sys*, *opt*) Function File

Convert a discrete (sub)system into a purely continuous one. The sampling time used is `sysgettsam(sys)`.

Inputs

sys system data structure with discrete components

tol Scalar value. Tolerance for convergence of default "log" option (see below)

opt conversion option. Choose from:

 "log" (default) Conversion is performed via a matrix logarithm. Due to some problems with this computation, it is followed by a steepest descent algorithm to identify continuous time *a*, *b*, to get a better fit to the original data. If called as `d2c (sys, tol)`, with *tol* positive scalar, the "log" option is used. The default value for *tol* is `1e-8`.

 "bi" Conversion is performed via bilinear transform $z = (1+sT/2)/(1-sT/2)$ where *T* is the system sampling time (see `sysgettsam`).
 FIXME: bilinear option exits with an error if *sys* is not purely discrete

Output

csys continuous time system (same dimensions and signal names as in *sys*).

`[dsys, fidx] = dmr2d (sys, idx, sprefix, ts2, cufg)` Function File
 convert a multirate digital system to a single rate digital system states specified by *idx*, *sprefix* are sampled at *ts2*, all others are assumed sampled at *ts1* = `sysgettsam (sys)`.

Inputs

sys discrete time system; `dmr2d` exits with an error if *sys* is not discrete

idx indices or names of states with sampling time `sysgettsam(sys)` (may be empty); see `cellidx`

sprefix list of string prefixes of states with sampling time `sysgettsam(sys)` (may be empty)

ts2 sampling time of states not specified by *idx*, *sprefix* must be an integer multiple of `sysgettsam(sys)`

cufg "constant u flag" if *cufg* is nonzero then the system inputs are assumed to be constant over the revised sampling interval *ts2*. Otherwise, since the inputs can change during the interval *t* in $[kts2, (k+1)ts2]$, an additional set of inputs is included in the revised B matrix so that these intersample inputs may be included in the single-rate system. default *cufg* = 1.

Outputs

- dsys* equivalent discrete time system with sampling time *ts2*.
The sampling time of *sys* is updated to *ts2*.
if *cufflg*=0 then a set of additional inputs is added to the system with suffixes *_d1*, ..., *_dn* to indicate their delay from the starting time *k ts2*, i.e. $u = [u_1; u_{1_d1}; \dots, u_{1_dn}]$ where u_{1_dk} is the input $k*ts1$ units of time after u_1 is sampled. (*ts1* is the original sampling time of the discrete time system and $ts2 = (n+1)*ts1$)
- idx* indices of "formerly fast" states specified by *idx* and *sprefix*; these states are updated to the new (slower) sampling interval *ts2*.

WARNING Not thoroughly tested yet; especially when *cufflg* == 0.

damp (*p*, *tsam*) Function File

Displays eigenvalues, natural frequencies and damping ratios of the eigenvalues of a matrix *p* or the *A* matrix of a system *p*, respectively. If *p* is a system, *tsam* must not be specified. If *p* is a matrix and *tsam* is specified, eigenvalues of *p* are assumed to be in *z*-domain.

dcgain (*sys*, *tol*) Function File

Returns dc-gain matrix. If dc-gain is infinite an empty matrix is returned. The argument *tol* is an optional tolerance for the condition number of the *A* Matrix in *sys* (default *tol* = 1.0e-10)

[y, t] = impulse (*sys*, *inp*, *tstop*, *n*) Function File

Impulse response for a linear system. The system can be discrete or multivariable (or both). If no output arguments are specified, **impulse** produces a plot or the impulse response data for system *sys*.

Inputs

- sys* System data structure.
- inp* Index of input being excited
- tstop* The argument *tstop* (scalar value) denotes the time when the simulation should end.
- n* the number of data values.
Both parameters *tstop* and *n* can be omitted and will be computed from the eigenvalues of the *A* Matrix.

Outputs

- y* Values of the impulse response.
- t* Times of the impulse response.

$[y, t] = \mathbf{step}(sys, inp, tstop, n)$ Function File

Step response for a linear system. The system can be discrete or multivariable (or both). If no output arguments are specified, **step** produces a plot or the step response data for system *sys*.

Inputs

sys System data structure.

inp Index of input being excited

tstop The argument *tstop* (scalar value) denotes the time when the simulation should end.

n the number of data values.

Both parameters *tstop* and *n* can be omitted and will be computed from the eigenvalues of the A Matrix.

Outputs

y Values of the step response.

t Times of the step response.

When invoked with the output parameter *y* the plot is not displayed.

29.8 System Analysis-Frequency Domain

Demonstration/tutorial script

frdemo () Function File

Octave Control Toolbox demo: Frequency Response demo.

$[mag, phase, w] = \mathbf{bode}(sys, w, out_idx, in_idx)$ Function File

If no output arguments are given: produce Bode plots of a system; otherwise, compute the frequency response of a system data structure

Inputs

sys a system data structure (must be either purely continuous or discrete; see `is_digital`)

w frequency values for evaluation.

if *sys* is continuous, then `bode` evaluates $G(jw)$ where $G(s)$ is the system transfer function.

if *sys* is discrete, then `bode` evaluates $G(\exp(jwT))$, where

- T is the system sampling time
- $G(z)$ is the system transfer function.

Default the default frequency range is selected as follows: (These steps are **not** performed if *w* is specified)

1. via routine `_bodquist_`, isolate all poles and zeros away from $w=0$ ($ju=0$ or $\exp(juT)=1$) and select the frequency range based on the breakpoint locations of the frequencies.
2. if `sys` is discrete time, the frequency range is limited to juT in $[0, 2\pi/T]$
3. A "smoothing" routine is used to ensure that the plot phase does not change excessively from point to point and that singular points (e.g., crossovers from ± 180) are accurately shown.

`out_idx`

`in_idx`

The names or indices of outputs and inputs to be used in the frequency response. See `sysprune`.

Example

```
bode(sys, [], "y_3", {"u_1", "u_4"});
```

Outputs

`mag`

`phase` the magnitude and phase of the frequency response $G(jw)$ or $G(\exp(juT))$ at the selected frequency values.

`w` the vector of frequency values used

1. If no output arguments are given, e.g.,

```
bode(sys);
```

`bode` plots the results to the screen. Descriptive labels are automatically placed.

Failure to include a concluding semicolon will yield some garbage being printed to the screen (`ans = []`).

2. If the requested plot is for an MIMO system, `mag` is set to $\|G(jw)\|$ or $\|G(\exp(juT))\|$ and phase information is not computed.

`[wmin, wmax] = bode_bounds (zer, pol, dflg, tsam)` Function File

Get default range of frequencies based on cutoff frequencies of system poles and zeros.

Frequency range is the interval $[10^{wmin}, 10^{wmax}]$

Used internally in `__freqresp__` (`bode`, `nyquist`)

`freqchkw (w)` Function File

Used by `__freqresp__` to check that input frequency vector `w` is valid. Returns boolean value.

`out = ltifr (a, b, w)` Function File

`out = ltifr (sys, w)` Function File

Linear time invariant frequency response of single-input systems.

Inputs

a
b coefficient matrices of $dx/dt = Ax + Bu$
sys system data structure
w vector of frequencies

Output

out frequency response, that is:

$$G(j\omega) = (j\omega I - A)^{-1}B$$

for complex frequencies $s = jw$.

`[realp, imagp, w] = nyquist (sys, w, out_idx, in_idx, atol)` Function File
nyquist (sys, w, out_idx, in_idx, atol) Function File

Produce Nyquist plots of a system; if no output arguments are given, Nyquist plot is printed to the screen.

Compute the frequency response of a system.

Inputs (pass as empty to get default values)

sys system data structure (must be either purely continuous or discrete; see `is_digital`)
w frequency values for evaluation. If *sys* is continuous, then `bode` evaluates $G(jw)$; if *sys* is discrete, then `bode` evaluates $G(\exp(jwT))$, where T is the system sampling time.

default the default frequency range is selected as follows: (These steps are **not** performed if *w* is specified)

1. via routine `__bodquist__`, isolate all poles and zeros away from $w=0$ ($jw=0$ or $\exp(jwT) = 1$) and select the frequency range based on the breakpoint locations of the frequencies.
2. if *sys* is discrete time, the frequency range is limited to jwT in $[0, 2p\pi]$
3. A “smoothing” routine is used to ensure that the plot phase does not change excessively from point to point and that singular points (e.g., crossovers from +/- 180) are accurately shown.

atol for interactive nyquist plots: *atol* is a change-in-slope tolerance for the of asymptotes (default = 0; 1e-2 is a good choice). This allows the user to “zoom in” on portions of the Nyquist plot too small to be seen with large asymptotes.

Outputs

realp
imagp the real and imaginary parts of the frequency response $G(jw)$ or $G(\exp(jwT))$ at the selected frequency values.
w the vector of frequency values used

If no output arguments are given, `nyquist` plots the results to the screen. If `atol != 0` and asymptotes are detected then the user is asked interactively if they wish to zoom in (remove asymptotes) Descriptive labels are automatically placed.

Note: if the requested plot is for an MIMO system, a warning message is presented; the returned information is of the magnitude $\|G(jw)\|$ or $\|G(\exp(jwT))\|$ only; phase information is not computed.

`[zer, gain] = tzero (a, b, c, d, opt)` Function File
`[zer, gain] = tzero (sys, opt)` Function File

Compute transmission zeros of a continuous system:

$$\dot{x} = Ax + Bu$$

$$y = Cx + Du$$

or of a discrete one:

$$x_{k+1} = Ax_k + Bu_k$$

$$y_k = Cx_k + Du_k$$

Outputs

`zer` transmission zeros of the system

`gain` leading coefficient (pole-zero form) of SISO transfer function returns gain=0 if system is multivariable

References

1. Emami-Naeini and Van Dooren, *Automatica*, 1982.
2. Hodel, *Computation of Zeros with Balancing*, 1992 Lin. Alg. Appl.

`zr = tzero2 (a, b, c, d, bal)` Function File
 Compute the transmission zeros of `a`, `b`, `c`, `d`.
`bal` = balancing option (see `balance`); default is "B".
 Needs to incorporate `mvzero` algorithm to isolate finite zeros; use `tzero` instead.

29.9 Controller Design

`dgkfdemo ()` Function File
 Octave Controls toolbox demo: $\mathcal{H}_2/\mathcal{H}_\infty$ options demos.

`hinfdemo ()` Function File
 \mathcal{H}_∞ design demos for continuous SISO and MIMO systems and a discrete system. The SISO system is difficult to control because it is non-minimum-phase and unstable. The second design example controls the `jet707` plant, the linearized state space model of a Boeing 707-321 aircraft at $v=80$ m/s ($M = 0.26$, $G_{a0} = -3^\circ$, $\alpha_0 = 4^\circ$, $\kappa = 50^\circ$). Inputs: (1) thrust and (2) elevator angle Outputs: (1) airspeed and (2) pitch angle. The discrete system is a stable and second order.

SISO plant:

$$G(s) = \frac{s - 2}{(s + 2)(s - 1)}$$

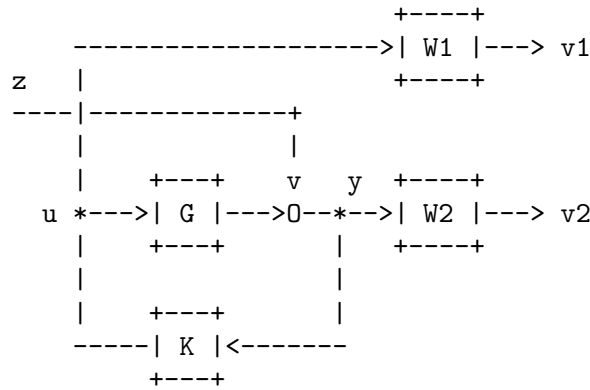

$$\min \|T_{vz}\|_{\infty}$$

$W1$ und $W2$ are the robustness and performance weighting functions.

MIMO plant:

The optimal controller minimizes the \mathcal{H}_{∞} norm of the augmented plant P (mixed-sensitivity problem):

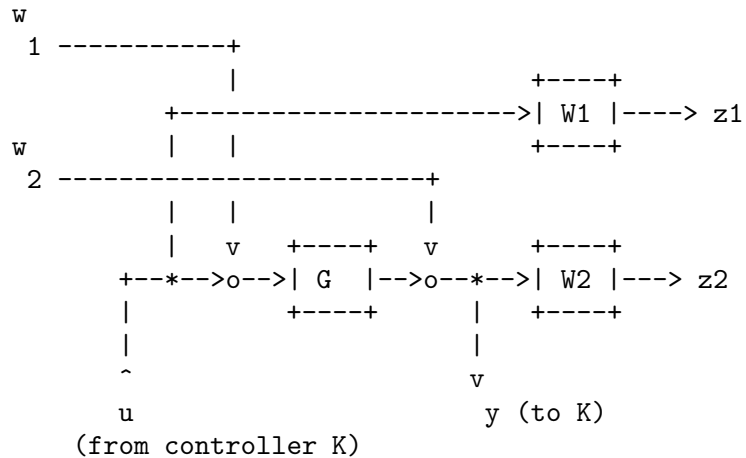

$$\begin{bmatrix} z_1 \\ z_2 \\ y \end{bmatrix} = P \begin{bmatrix} w_1 \\ w_2 \\ u \end{bmatrix}$$

Discrete system:

This is not a true discrete design. The design is carried out in continuous time while the effect of sampling is described by a bilinear transformation of the sampled system. This method works quite well if the sampling period is “small” compared to the plant time constants.

The continuous plant:

$$G(s) = \frac{1}{(s + 2)(s + 1)}$$

is discretised with a ZOH (Sampling period = $T_s = 1$ second):

$$G(z) = \frac{0.199788z + 0.073498}{(z - 0.36788)(z - 0.13534)}$$

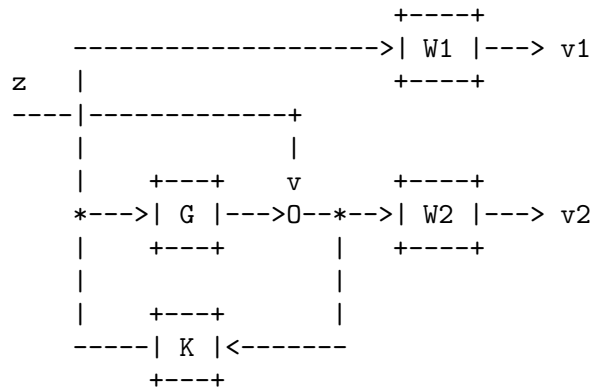

$$\min \|T_{vz}\|_{\infty}$$

$W1$ and $W2$ are the robustness and performance weighting functions.

$[l, m, p, e] = \mathbf{dlqe}(a, g, c, sigw, sigv, z)$ Function File
 Construct the linear quadratic estimator (Kalman filter) for the discrete time system

$$x_{k+1} = Ax_k + Bu_k + Gw_k$$

$$y_k = Cx_k + Du_k + v_k$$

where w, v are zero-mean gaussian noise processes with respective intensities $sigw = \text{cov}(w, w)$ and $sigv = \text{cov}(v, v)$.

If specified, z is $\text{cov}(w, v)$. Otherwise $\text{cov}(w, v) = 0$.

The observer structure is

$$z_{k|k} = z_{k|k-1} + l(y_k - Cz_{k|k-1} - Du_k)$$

$$z_{k+1|k} = Az_{k|k} + Bu_k$$

The following values are returned:

- l The observer gain, $(A - ALC)$. is stable.
- m The Riccati equation solution.
- p The estimate error covariance after the measurement update.
- e The closed loop poles of $(A - ALC)$.

$[k, p, e] = \mathbf{dlqr}(a, b, q, r, z)$

Function File

Construct the linear quadratic regulator for the discrete time system

$$x_{k+1} = Ax_k + Bu_k$$

to minimize the cost functional

$$J = \sum x^T Qx + u^T Ru$$

z omitted or

$$J = \sum x^T Qx + u^T Ru + 2x^T Zu$$

z included.

The following values are returned:

- k The state feedback gain, $(A - BK)$ is stable.
- p The solution of algebraic Riccati equation.
- e The closed loop poles of $(A - BK)$.

$[Lp, Lf, P, Z] = \mathbf{dkalman}(A, G, C, Qw, Rv, S)$

Function File

Construct the linear quadratic estimator (Kalman predictor) for the discrete time system

$$x_{k+1} = Ax_k + Bu_k + Gw_k$$

$$y_k = Cx_k + Du_k + v_k$$

where w, v are zero-mean gaussian noise processes with respective intensities $Qw = \text{cov}(w, w)$ and $Rv = \text{cov}(v, v)$.

If specified, S is $\text{cov}(w, v)$. Otherwise $\text{cov}(w, v) = 0$.

The observer structure is $x_{k+1|k} = Ax_{k|k-1} + Bu_k + L_p(y_k - Cx_{k|k-1} - Du_k)$ $x_{k|k} = x_{k|k} + L_f(y_k - Cx_{k|k-1} - Du_k)$

The following values are returned:

- Lp The predictor gain, $(A - L_p C)$. is stable.
- Lf The filter gain.
- P The Riccati solution. $P = E\{(x - x_{n|n-1})(x - x_{n|n-1})'\}$
- Z The updated error covariance matrix. $Z = E\{(x - x_{n|n})(x - x_{n|n})'\}$

$[K, \text{gain}, kc, kf, pc, pf] = \mathbf{h2syn}(asys, nu, ny, tol)$

Function File

Design \mathcal{H}_2 optimal controller per procedure in Doyle, Glover, Khargonekar, Francis, *State-Space Solutions to Standard \mathcal{H}_2 and \mathcal{H}_∞ Control Problems*, IEEE TAC August 1989.

Discrete-time control per Zhou, Doyle, and Glover, *Robust and optimal control*, Prentice-Hall, 1996.

Inputs

asys system data structure (see `ss`, `sys2ss`)

- controller is implemented for continuous time systems
- controller is **not** implemented for discrete time systems

nu number of controlled inputs

ny number of measured outputs

tol threshold for 0. Default: `200*eps`

Outputs

k system controller

gain optimal closed loop gain

kc full information control (packed)

kf state estimator (packed)

pc ARE solution matrix for regulator subproblem

pf ARE solution matrix for filter subproblem

$K = \mathbf{hinf_ctr}(dgs, f, h, z, g)$

Function File

Called by `hinfsyn` to compute the \mathcal{H}_∞ optimal controller.

Inputs

dgs data structure returned by `is_dgkf`

f

h feedback and filter gain (not partitioned)

g final gamma value

Outputs

K controller (system data structure)

Do not attempt to use this at home; no argument checking performed.

$[k, g, gw, xinf, yinf] = \mathbf{hinfsyn}(asys, nu, ny, gmin, gmax, gtol, ptol, tol)$

Function File

Inputs input system is passed as either

asys system data structure (see `ss`, `sys2ss`)

- controller is implemented for continuous time systems
- controller is **not** implemented for discrete time systems (see bilinear transforms in `c2d`, `d2c`)

nu number of controlled inputs

ny number of measured outputs

gmin initial lower bound on \mathcal{H}_∞ optimal gain

gmax initial upper bound on \mathcal{H}_∞ Optimal gain.
gtol Gain threshold. Routine quits when $gmax/gmin < 1+tol$.
ptol poles with $\text{abs}(\text{real}(\text{pole})) < ptol\|H\|$ (H is appropriate Hamiltonian) are considered to be on the imaginary axis. Default: $1e-9$.
tol threshold for 0. Default: $200*\text{eps}$.
gmax, *min*, *tol*, and *tol* must all be positive scalars.

Outputs

k System controller.
g Designed gain value.
gw Closed loop system.
xinf ARE solution matrix for regulator subproblem.
yinf ARE solution matrix for filter subproblem.

References:

1. Doyle, Glover, Khargonekar, Francis, *State-Space Solutions to Standard \mathcal{H}_2 and \mathcal{H}_∞ Control Problems*, IEEE TAC August 1989.
2. Maciejowski, J.M., *Multivariable feedback design*, Addison-Wesley, 1989, ISBN 0-201-18243-2.
3. Keith Glover and John C. Doyle, *State-space formulae for all stabilizing controllers that satisfy an \mathcal{H}_∞ norm bound and relations to risk sensitivity*, Systems & Control Letters 11, Oct. 1988, pp 167–172.

$[retval, pc, pf] = \text{hinfsyn_chk}(a, b1, b2, c1, c2, d12, d21, g, ptol)$ Function File

Called by `hinfsyn` to see if gain g satisfies conditions in Theorem 3 of Doyle, Glover, Khargonekar, Francis, *State Space Solutions to Standard \mathcal{H}_2 and \mathcal{H}_∞ Control Problems*, IEEE TAC August 1989.

Warning: do not attempt to use this at home; no argument checking performed.

Inputs

As returned by `is_dgkf`, except for:

g candidate gain level
ptol as in `hinfsyn`

Outputs

retval 1 if g exceeds optimal Hinf closed loop gain, else 0
pc solution of “regulator” \mathcal{H}_∞ ARE
pf solution of “filter” \mathcal{H}_∞ ARE

Do not attempt to use this at home; no argument checking performed.

$[xinf, x_ha_err] = \mathbf{hinfosyn_ric} (a, bb, c1, d1dot, r, ptol)$ Function File
Forms

```
xx = ([bb; -c1'*d1dot]/r) * [d1dot'*c1 bb'];
Ha = [a 0*a; -c1'*c1 - a'] - xx;
```

and solves associated Riccati equation. The error code x_ha_err indicates one of the following conditions:

- | | |
|---|--|
| 0 | successful |
| 1 | $xinf$ has imaginary eigenvalues |
| 2 | hx not Hamiltonian |
| 3 | $xinf$ has infinite eigenvalues (numerical overflow) |
| 4 | $xinf$ not symmetric |
| 5 | $xinf$ not positive definite |
| 6 | r is singular |

$[k, p, e] = \mathbf{lqe} (a, g, c, sigw, sigv, z)$ Function File

Construct the linear quadratic estimator (Kalman filter) for the continuous time system

$$\frac{dx}{dt} = Ax + Bu$$

$$y = Cx + Du$$

where w and v are zero-mean gaussian noise processes with respective intensities

```
sigw = cov (w, w)
sigv = cov (v, v)
```

The optional argument z is the cross-covariance $\text{cov}(w, v)$. If it is omitted, $\text{cov}(w, v) = 0$ is assumed.

Observer structure is $dz/dt = A z + B u + k (y - C z - D u)$

The following values are returned:

- | | |
|-----|---|
| k | The observer gain, $(A - KC)$ is stable. |
| p | The solution of algebraic Riccati equation. |
| e | The vector of closed loop poles of $(A - KC)$. |

$[k, q1, p1, ee, er] = \mathbf{lqg} (sys, sigw, sigv, q, r, in_idx)$ Function File

Design a linear-quadratic-gaussian optimal controller for the system

$$\begin{aligned} dx/dt &= A x + B u + G w & [w] &= N(0, [Sigw \ 0 \]) \\ y &= C x + v & [v] &= (\ 0 \ Sigv \) \end{aligned}$$

or

$$\begin{aligned} x(k+1) &= A x(k) + B u(k) + G w(k) & [w] &= N(0, [Sigw \ 0 \]) \\ y(k) &= C x(k) + v(k) & [v] &= (\ 0 \ Sigv \) \end{aligned}$$

Inputs

<i>sys</i>	system data structure
<i>sigw</i>	
<i>sigv</i>	intensities of independent Gaussian noise processes (as above)
<i>q</i>	
<i>r</i>	state, control weighting respectively. Control ARE is
<i>in_idx</i>	names or indices of controlled inputs (see <code>sysidx</code> , <code>cellidx</code>) default: last dim(R) inputs are assumed to be controlled inputs, all others are assumed to be noise inputs.

Outputs

<i>k</i>	system data structure format LQG optimal controller (Obtain A, B, C matrices with <code>sys2ss</code> , <code>sys2tf</code> , or <code>sys2zp</code> as appropriate).
<i>p1</i>	Solution of control (state feedback) algebraic Riccati equation.
<i>q1</i>	Solution of estimation algebraic Riccati equation.
<i>ee</i>	Estimator poles.
<i>es</i>	Controller poles.

$[k, p, e] = \mathbf{lqr}(a, b, q, r, z)$ Function File
construct the linear quadratic regulator for the continuous time system

$$\frac{dx}{dt} = Ax + Bu$$

to minimize the cost functional

$$J = \int_0^{\infty} x^T Qx + u^T Ru$$

z omitted or

$$J = \int_0^{\infty} x^T Qx + u^T Ru + 2x^T Zu$$

z included.

The following values are returned:

<i>k</i>	The state feedback gain, $(A - BK)$ is stable and minimizes the cost functional
<i>p</i>	The stabilizing solution of appropriate algebraic Riccati equation.
<i>e</i>	The vector of the closed loop poles of $(A - BK)$.

Reference Anderson and Moore, *Optimal control: linear quadratic methods*, Prentice-Hall, 1990, pp. 56–58.

[y, x] = lsim (*sys, u, t, x0*) Function File

Produce output for a linear simulation of a system; produces a plot for the output of the system, *sys*.

u is an array that contains the system's inputs. Each row in *u* corresponds to a different time step. Each column in *u* corresponds to a different input. *t* is an array that contains the time index of the system; *t* should be regularly spaced. If initial conditions are required on the system, the *x0* vector should be added to the argument list.

When the *lsim* function is invoked a plot is not displayed; however, the data is returned in *y* (system output) and *x* (system states).

K = place (*sys, p*) Function File

Computes the matrix *K* such that if the state is feedback with gain *K*, then the eigenvalues of the closed loop system (i.e. $A - BK$) are those specified in the vector *p*.

Version: Beta (May-1997): If you have any comments, please let me know. (see the file *place.m* for my address)

29.10 Miscellaneous Functions (Not yet properly filed/documented)

axis2dlim (*axdata*) Function File

Determine axis limits for 2-D data (column vectors); leaves a 10% margin around the plots. Inserts margins of +/- 0.1 if data is one-dimensional (or a single point).

Input

axdata *n* by 2 matrix of data [*x, y*].

Output

axvec Vector of axis limits appropriate for call to *axis* function.

moddemo (*inputs*) Function File

Octave Control toolbox demo: Model Manipulations demo.

prompt (*str*) Function File

Prompt user to continue

Input

str Input string. Its default value is:
 \n ---- Press a key to continue ---

rldemo (*inputs*) Function File

Octave Control toolbox demo: Root Locus demo.

`[rldata, k] = rlocus (sys[, increment, min_k, max_k])` Function File
 Displays root locus plot of the specified SISO system.

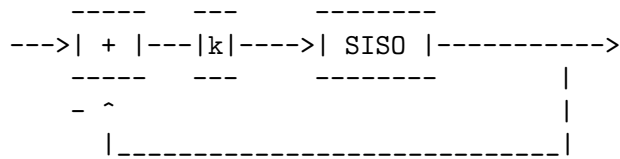
**Inputs**

sys system data structure
min_k Minimum value of *k*
max_k Maximum value of *k*
increment The increment used in computing gain values

Outputs

Plots the root locus to the screen.
rldata Data points plotted: in column 1 real values, in column 2 the imaginary values.
k Gains for real axis break points.

`[yy, idx] = sortcom (xx[, opt])` Function File
 Sort a complex vector.

Inputs

xx Complex vector
opt sorting option:
 "re" Real part (default);
 "mag" By magnitude;
 "im" By imaginary part.
 if *opt* is not chosen as "im", then complex conjugate pairs are grouped together, $a - jb$ followed by $a + jb$.

Outputs

yy Sorted values
idx Permutation vector: $yy = xx(idx)$

`[num, den] = ss2tf (a, b, c, d)` Function File
 Conversion from transfer function to state-space. The state space system:

$$\dot{x} = Ax + Bu$$

$$y = Cx + Du$$

is converted to a transfer function:

$$G(s) = \frac{\text{num}(s)}{\text{den}(s)}$$

used internally in system data structure format manipulations.

$[pol, zer, k] = \mathbf{ss2zp} (a, b, c, d)$ Function File
 Converts a state space representation to a set of poles and zeros; k is a gain associated with the zeros.
 Used internally in system data structure format manipulations.

$\mathbf{starp} (P, K, ny, nu)$ Function File
 Redheffer star product or upper/lower LFT, respectively.

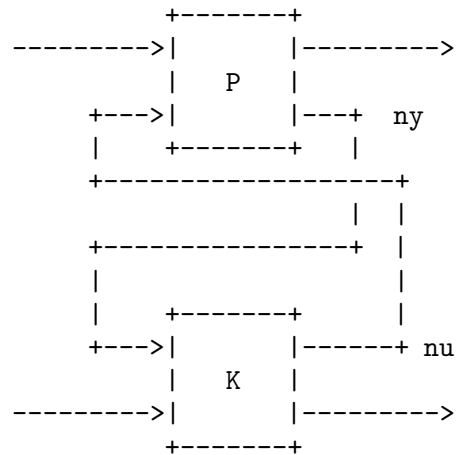

If ny and nu “consume” all inputs and outputs of K then the result is a lower fractional transformation. If ny and nu “consume” all inputs and outputs of P then the result is an upper fractional transformation.

ny and/or nu may be negative (i.e. negative feedback).

$[a, b, c, d] = \mathbf{tf2ss} (num, den)$ Function File
 Conversion from transfer function to state-space. The state space system:

$$\dot{x} = Ax + Bu$$

$$y = Cx + Du$$

is obtained from a transfer function:

$$G(s) = \frac{\text{num}(s)}{\text{den}(s)}$$

The vector den must contain only one row, whereas the vector num may contain as many rows as there are outputs y of the system. The state space system matrices obtained from this function will be in controllable canonical form as described in *Modern Control Theory*, (Brogan, 1991).

$[zer, pol, k] = \mathbf{tf2zp} (num, den)$ Function File
 Converts transfer functions to poles-and-zero representations.
 Returns the zeros and poles of the SISO system defined by num/den . k is a gain associated with the system zeros.

$[a, b, c, d] = \mathbf{zp2ss}(zer, pol, k)$ Function File

Conversion from zero / pole to state space.

Inputs

zer

pol Vectors of (possibly) complex poles and zeros of a transfer function. Complex values must come in conjugate pairs (i.e., $x+jy$ in *zer* means that $x-jy$ is also in *zer*). The number of zeros must not exceed the number of poles.

k Real scalar (leading coefficient).

Outputs

a

b

c

d The state space system, in the form:

$$\dot{x} = Ax + Bu$$

$$y = Cx + Du$$

$[num, den] = \mathbf{zp2tf}(zer, pol, k)$ Function File

Converts zeros / poles to a transfer function.

Inputs

zer

pol Vectors of (possibly complex) poles and zeros of a transfer function. Complex values must appear in conjugate pairs.

k Real scalar (leading coefficient).

30 Signal Processing

I hope that someday Octave will include more signal processing functions. If you would like to help improve Octave in this area, please contact `bug-octave@bevo.che.wisc.edu`.

detrend (*x*, *p*) Function File

If *x* is a vector, `detrend` (*x*, *p*) removes the best fit of a polynomial of order *p* from the data *x*.

If *x* is a matrix, `detrend` (*x*, *p*) does the same for each column in *x*.

The second argument is optional. If it is not specified, a value of 1 is assumed. This corresponds to removing a linear trend.

fft (*a*, *n*, *dim*) Loadable Function

Compute the FFT of *a* using subroutines from FFTW. The FFT is calculated along the first non-singleton dimension of the array. Thus if *a* is a matrix, `fft` (*a*) computes the FFT for each column of *a*.

If called with two arguments, *n* is expected to be an integer specifying the number of elements of *a* to use, or an empty matrix to specify that its value should be ignored. If *n* is larger than the dimension along which the FFT is calculated, then *a* is resized and padded with zeros. Otherwise, if *n* is smaller than the dimension along which the FFT is calculated, then *a* is truncated.

If called with three arguments, *dim* is an integer specifying the dimension of the matrix along which the FFT is performed

ifft (*a*, *n*, *dim*) Loadable Function

Compute the inverse FFT of *a* using subroutines from FFTW. The inverse FFT is calculated along the first non-singleton dimension of the array. Thus if *a* is a matrix, `ifft` (*a*) computes the inverse FFT for each column of *a*.

If called with two arguments, *n* is expected to be an integer specifying the number of elements of *a* to use, or an empty matrix to specify that its value should be ignored. If *n* is larger than the dimension along which the inverse FFT is calculated, then *a* is resized and padded with zeros. Otherwise, if *n* is smaller than the dimension along which the inverse FFT is calculated, then *a* is truncated.

If called with three arguments, *dim* is an integer specifying the dimension of the matrix along which the inverse FFT is performed

fft2 (*a*, *n*, *m*) Loadable Function

Compute the two dimensional FFT of *a* using subroutines from FFTW. The optional arguments *n* and *m* may be used specify the number of rows and columns of *a* to use. If either of these is larger than the size of *a*, *a* is resized and padded with zeros.

If *a* is a multi-dimensional matrix, each two-dimensional sub-matrix of *a* is treated separately

fft2 (*a*, *n*, *m*) Loadable Function

Compute the inverse two dimensional FFT of *a* using subroutines from FFTW. The optional arguments *n* and *m* may be used specify the number of rows and columns of *a* to use. If either of these is larger than the size of *a*, *a* is resized and padded with zeros.

If *a* is a multi-dimensional matrix, each two-dimensional sub-matrix of *a* is treated separately

fftn (*a*, *size*) Loadable Function

Compute the N dimensional FFT of *a* using subroutines from FFTW. The optional vector argument *size* may be used specify the dimensions of the array to be used. If an element of *size* is smaller than the corresponding dimension, then the dimension is truncated prior to performing the FFT. Otherwise if an element of *size* is larger than the corresponding dimension *a* is resized and padded with zeros.

ifftn (*a*, *size*) Loadable Function

Compute the inverse N dimensional FFT of *a* using subroutines from FFTW. The optional vector argument *size* may be used specify the dimensions of the array to be used. If an element of *size* is smaller than the corresponding dimension, then the dimension is truncated prior to performing the inverse FFT. Otherwise if an element of *size* is larger than the corresponding dimension *a* is resized and padded with zeros.

fftconv (*a*, *b*, *n*) Function File

Return the convolution of the vectors *a* and *b*, as a vector with length equal to the `length (a) + length (b) - 1`. If *a* and *b* are the coefficient vectors of two polynomials, the returned value is the coefficient vector of the product polynomial.

The computation uses the FFT by calling the function `fftfilt`. If the optional argument *n* is specified, an N-point FFT is used.

fftfilt (*b*, *x*, *n*) Function File

With two arguments, `fftfilt` filters *x* with the FIR filter *b* using the FFT.

Given the optional third argument, *n*, `fftfilt` uses the overlap-add method to filter *x* with *b* using an N-point FFT.

If *x* is a matrix, filter each column of the matrix.

y = filter (*b*, *a*, *x*) Loadable Function

[y, sf] = filter (*b*, *a*, *x*, *si*) Loadable Function

[y, sf] = filter (*b*, *a*, *x*, [], *dim*) Loadable Function

[y, sf] = filter (*b*, *a*, *x*, *si*, *dim*) Loadable Function

Return the solution to the following linear, time-invariant difference equation:

$$\sum_{k=0}^N a_{k+1} y_{n-k} = \sum_{k=0}^M b_{k+1} x_{n-k}, \quad 1 \leq n \leq P$$

where $a \in \mathfrak{R}^{N-1}$, $b \in \mathfrak{R}^{M-1}$, and $x \in \mathfrak{R}^P$. over the first non-singleton dimension of x or over dim if supplied. An equivalent form of this equation is:

$$y_n = - \sum_{k=1}^N c_{k+1} y_{n-k} + \sum_{k=0}^M d_{k+1} x_{n-k}, \quad 1 \leq n \leq P$$

where $c = a/a_1$ and $d = b/a_1$.

If the fourth argument si is provided, it is taken as the initial state of the system and the final state is returned as sf . The state vector is a column vector whose length is equal to the length of the longest coefficient vector minus one. If si is not supplied, the initial state vector is set to all zeros.

In terms of the z-transform, y is the result of passing the discrete-time signal x through a system characterized by the following rational system function:

$$H(z) = \frac{\sum_{k=0}^M d_{k+1} z^{-k}}{1 + \sum_{k=1}^N c_{k+1} z^{-k}}$$

`[h, w] = freqz (b, a, n, "whole")` Function File

Return the complex frequency response h of the rational IIR filter whose numerator and denominator coefficients are b and a , respectively. The response is evaluated at n angular frequencies between 0 and 2π .

The output value w is a vector of the frequencies.

If the fourth argument is omitted, the response is evaluated at frequencies between 0 and π .

If n is omitted, a value of 512 is assumed.

If a is omitted, the denominator is assumed to be 1 (this corresponds to a simple FIR filter).

For fastest computation, n should factor into a small number of small primes.

`h = freqz (b, a, w)` Function File

Evaluate the response at the specific frequencies in the vector w . The values for w are measured in radians.

`[...] = freqz (... , Fs)` Function File

Return frequencies in Hz instead of radians assuming a sampling rate F_s . If you are evaluating the response at specific frequencies w , those frequencies should be requested in Hz rather than radians.

`freqz (...)` Function File

Plot the pass band, stop band and phase response of h rather than returning them.

`freqz_plot (w, h)` Function File

Plot the pass band, stop band and phase response of h .

sinc (*x*) Function File
 Return $\sin(\pi x)/(\pi x)$.

b = unwrap (*a*, *tol*, *dim*) Function File
 Unwrap radian phases by adding multiples of 2π as appropriate to remove jumps greater than *tol*. *tol* defaults to π .
 Unwrap will unwrap along the first non-singleton dimension of *a*, unless the optional argument *dim* is given, in which case the data will be unwrapped along this dimension

[a, b] = arch_fit (*y*, *x*, *p*, *iter*, *gamma*, *a0*, *b0*) Function File
 Fit an ARCH regression model to the time series *y* using the scoring algorithm in Engle's original ARCH paper. The model is

$$\begin{aligned} y(t) &= b(1) * x(t,1) + \dots + b(k) * x(t,k) + e(t), \\ h(t) &= a(1) + a(2) * e(t-1)^2 + \dots + a(p+1) * e(t-p)^2 \end{aligned}$$

in which $e(t)$ is $N(0, h(t))$, given a time-series vector *y* up to time $t - 1$ and a matrix of (ordinary) regressors *x* up to *t*. The order of the regression of the residual variance is specified by *p*.

If invoked as **arch_fit** (*y*, *k*, *p*) with a positive integer *k*, fit an ARCH(*k*, *p*) process, i.e., do the above with the *t*-th row of *x* given by

$$[1, y(t-1), \dots, y(t-k)]$$

Optionally, one can specify the number of iterations *iter*, the updating factor *gamma*, and initial values *a0* and *b0* for the scoring algorithm.

arch_rnd (*a*, *b*, *t*) Function File
 Simulate an ARCH sequence of length *t* with AR coefficients *b* and CH coefficients *a*. I.e., the result $y(t)$ follows the model

$$y(t) = b(1) + b(2) * y(t-1) + \dots + b(lb) * y(t-lb+1) + e(t),$$

where $e(t)$, given *y* up to time $t - 1$, is $N(0, h(t))$, with

$$h(t) = a(1) + a(2) * e(t-1)^2 + \dots + a(la) * e(t-la+1)^2$$

[pval, lm] = arch_test (*y*, *x*, *p*) Function File
 For a linear regression model

$$y = x * b + e$$

perform a Lagrange Multiplier (LM) test of the null hypothesis of no conditional heteroscedascity against the alternative of CH(*p*).

I.e., the model is

$$y(t) = b(1) * x(t,1) + \dots + b(k) * x(t,k) + e(t),$$

given *y* up to $t - 1$ and *x* up to *t*, $e(t)$ is $N(0, h(t))$ with

$$h(t) = v + a(1) * e(t-1)^2 + \dots + a(p) * e(t-p)^2,$$

and the null is $a(1) == \dots == a(p) == 0$.

If the second argument is a scalar integer, *k*, perform the same test in a linear autoregression model of order *k*, i.e., with

$$[1, y(t-1), \dots, y(t-k)]$$

as the t -th row of x .

Under the null, LM approximately has a chisquare distribution with p degrees of freedom and $pval$ is the p -value (1 minus the CDF of this distribution at LM) of the test.

If no output argument is given, the p -value is displayed.

arma_rnd (a, b, v, t, n) Function File

Return a simulation of the ARMA model

$$x(n) = a(1) * x(n-1) + \dots + a(k) * x(n-k) \\ + e(n) + b(1) * e(n-1) + \dots + b(l) * e(n-l)$$

in which k is the length of vector a , l is the length of vector b and e is gaussian white noise with variance v . The function returns a vector of length t .

The optional parameter n gives the number of dummy $x(i)$ used for initialization, i.e., a sequence of length $t+n$ is generated and $x(n+1:t+n)$ is returned. If n is omitted, $n = 100$ is used.

autocor (x, h) Function File

Return the autocorrelations from lag 0 to h of vector x . If h is omitted, all autocorrelations are computed. If x is a matrix, the autocorrelations of each column are computed.

autocov (x, h) Function File

Return the autocovariances from lag 0 to h of vector x . If h is omitted, all autocovariances are computed. If x is a matrix, the autocovariances of each column are computed.

autoreg_matrix (y, k) Function File

Given a time series (vector) y , return a matrix with ones in the first column and the first k lagged values of y in the other columns. I.e., for $t > k$, $[1, y(t-1), \dots, y(t-k)]$ is the t -th row of the result. The resulting matrix may be used as a regressor matrix in autoregressions.

bartlett (m) Function File

Return the filter coefficients of a Bartlett (triangular) window of length m .

For a definition of the Bartlett window, see e.g. A. V. Oppenheim & R. W. Schaffer, "Discrete-Time Signal Processing".

blackman (m) Function File

Return the filter coefficients of a Blackman window of length m .

For a definition of the Blackman window, see e.g. A. V. Oppenheim & R. W. Schaffer, "Discrete-Time Signal Processing".

[d, dd] = diffpara (x, a, b) Function File

Return the estimator d for the differencing parameter of an integrated time series.

The frequencies from $[2 * \pi * a/T, 2 * \pi * b/T]$ are used for the estimation. If b is omitted, the interval $[2 * \pi/T, 2 * \pi * a/T]$ is used. If both b and a are omitted then $a = 0.5 * \sqrt{T}$ and $b = 1.5 * \sqrt{T}$ is used, where T is the sample size. If x is a matrix, the differencing parameter of each column is estimated.

The estimators for all frequencies in the intervals described above is returned in dd . The value of d is simply the mean of dd .

Reference: Brockwell, Peter J. & Davis, Richard A. Time Series: Theory and Methods Springer 1987.

durbinlevinson (c, oldphi, oldv) Function File

Perform one step of the Durbin-Levinson algorithm.

The vector c specifies the autocovariances $[\text{gamma}_0, \dots, \text{gamma}_t]$ from lag 0 to t , $oldphi$ specifies the coefficients based on $c(t-1)$ and $oldv$ specifies the corresponding error.

If $oldphi$ and $oldv$ are omitted, all steps from 1 to t of the algorithm are performed.

fftshift (v) Function File

fftshift (v, dim) Function File

Perform a shift of the vector v , for use with the `fft` and `ifft` functions, in order to move the frequency 0 to the center of the vector or matrix.

If v is a vector of N elements corresponding to N time samples spaced of Dt each, then `fftshift (fft (v))` corresponds to frequencies

$$f = ((1:N) - \text{ceil}(N/2)) / N / Dt$$

If v is a matrix, the same holds for rows and columns. If v is an array, then the same holds along each dimension.

The optional dim argument can be used to limit the dimension along which the permutation occurs.

fractdiff (x, d) Function File

Compute the fractional differences $(1 - L)^d x$ where L denotes the lag-operator and d is greater than -1.

hamming (m) Function File

Return the filter coefficients of a Hamming window of length m .

For a definition of the Hamming window, see e.g. A. V. Oppenheim & R. W. Schaffer, "Discrete-Time Signal Processing".

hanning (m) Function File

Return the filter coefficients of a Hanning window of length m .

For a definition of this window type, see e.g. A. V. Oppenheim & R. W. Schaffer, "Discrete-Time Signal Processing".

- hurst** (*x*) Function File
Estimate the Hurst parameter of sample *x* via the rescaled range statistic. If *x* is a matrix, the parameter is estimated for every single column.
- periodogram** (*x*) Function File
For a data matrix *x* from a sample of size *n*, return the periodogram.
- rectangle_lw** (*n*, *b*) Function File
Rectangular lag window. Subfunction used for spectral density estimation.
- rectangle_sw** (*n*, *b*) Function File
Rectangular spectral window. Subfunction used for spectral density estimation.
- sinetone** (*freq*, *rate*, *sec*, *ampl*) Function File
Return a sinetone of frequency *freq* with length of *sec* seconds at sampling rate *rate* and with amplitude *ampl*. The arguments *freq* and *ampl* may be vectors of common size.
Defaults are *rate* = 8000, *sec* = 1 and *ampl* = 64.
- sinewave** (*m*, *n*, *d*) Function File
Return an *m*-element vector with *i*-th element given by $\sin(2 * \pi * (i+d-1) / n)$.
The default value for *d* is 0 and the default value for *n* is *m*.
- spectral_adf** (*c*, *win*, *b*) Function File
Return the spectral density estimator given a vector of autocovariances *c*, window name *win*, and bandwidth, *b*.
The window name, e.g., "triangle" or "rectangle" is used to search for a function called *win_sw*.
If *win* is omitted, the triangle window is used. If *b* is omitted, $1 / \sqrt{\text{length}(x)}$ is used.
- spectral_xdf** (*x*, *win*, *b*) Function File
Return the spectral density estimator given a data vector *x*, window name *win*, and bandwidth, *b*.
The window name, e.g., "triangle" or "rectangle" is used to search for a function called *win_sw*.
If *win* is omitted, the triangle window is used. If *b* is omitted, $1 / \sqrt{\text{length}(x)}$ is used.
- spencer** (*x*) Function File
Return Spencer's 15 point moving average of every single column of *x*.

`[y, c] = stft (x, win_size, inc, num_coef, w_type)` Function File

Compute the short-term Fourier transform of the vector x with num_coef coefficients by applying a window of win_size data points and an increment of inc points.

Before computing the Fourier transform, one of the following windows is applied:

hanning `w_type = 1`

hamming `w_type = 2`

rectangle `w_type = 3`

The window names can be passed as strings or by the w_type number.

If not all arguments are specified, the following defaults are used: $win_size = 80$, $inc = 24$, $num_coef = 64$, and $w_type = 1$.

`y = stft (x, ...)` returns the absolute values of the Fourier coefficients according to the num_coef positive frequencies.

`[y, c] = stft (x, ...)` returns the entire STFT-matrix y and a 3-element vector c containing the window size, increment, and window type, which is needed by the synthesis function.

synthesis (y, c) Function File

Compute a signal from its short-time Fourier transform y and a 3-element vector c specifying window size, increment, and window type.

The values y and c can be derived by

`[y, c] = stft (x , ...)`

triangle_lw (n, b) Function File

Triangular lag window. Subfunction used for spectral density estimation.

triangle_sw (n, b) Function File

Triangular spectral window. Subfunction used for spectral density estimation.

`[a, v] = yulewalker (c)` Function File

Fit an AR (p)-model with Yule-Walker estimates given a vector c of autocovariances `[gamma_0, ..., gamma_p]`.

Returns the AR coefficients, a , and the variance of white noise, v .

31 Image Processing

Octave can display images with the X Window System using the `xloadimage` program. You do not need to be running X in order to manipulate images, however, so some of these functions may be useful even if you are not able to view the results.

Loading images only works with Octave's image format (a file with a matrix containing the image data, and a matrix containing the colormap). Contributions of robust, well-written functions to read other image formats are welcome. If you can provide them, or would like to improve Octave's image processing capabilities in other ways, please contact `bug-octave@bevo.che.wisc.edu`.

colormap (*map*) Function File

colormap ("default") Function File

Set the current colormap.

`colormap` (*map*) sets the current colormap to *map*. The color map should be an *n* row by 3 column matrix. The columns contain red, green, and blue intensities respectively. All entries should be between 0 and 1 inclusive. The new colormap is returned.

`colormap` ("default") restores the default colormap (a gray scale colormap with 64 entries). The default colormap is returned.

With no arguments, `colormap` returns the current color map.

gray (*n*) Function File

Return a gray colormap with *n* entries corresponding to values from 0 to *n*-1. The argument *n* should be a scalar. If it is omitted, 64 is assumed.

`[img, map] = gray2ind` () Function File

Convert a gray scale intensity image to an Octave indexed image.

image (*x*, *zoom*) Function File

image (*x*, *y*, *A*, *zoom*) Function File

Display a matrix as a color image. The elements of *x* are indices into the current colormap and should have values between 1 and the length of the colormap. If *zoom* is omitted, the image will be scaled to fit within 600x350 (to a max of 4).

It first tries to use `display` from `ImageMagick` then `xv` and then `xloadimage`.

The axis values corresponding to the matrix elements are specified in *x* and *y*. At present they are ignored.

imagesc (*A*) Function File

imagesc (*x*, *y*, *A*) Function File

imagesc (... , *zoom*) Function File

imagesc (... , *limits*) Function File

B = **imagesc** (...) Function File

Display a scaled version of the matrix *A* as a color image. The matrix is scaled so that its entries are indices into the current colormap. The scaled matrix is returned.

If *zoom* is omitted, a comfortable size is chosen. If *limits* = [*lo*, *hi*] are given, then that range maps into the full range of the colormap rather than the minimum and maximum values of *A*.

The axis values corresponding to the matrix elements are specified in *x* and *y*, either as pairs giving the minimum and maximum values for the respective axes, or as values for each row and column of the matrix *A*. At present they are ignored.

imshow (<i>i</i>)	Function File
imshow (<i>x</i> , <i>map</i>)	Function File
imshow (<i>x</i> , <i>n</i>)	Function File
imshow (<i>i</i> , <i>n</i>)	Function File
imshow (<i>r</i> , <i>g</i> , <i>b</i>)	Function File

Display an image.

imshow (*x*) displays an intensity image, estimating the number of gray levels.

imshow (*x*, *map*) displays an indexed image using the specified colormap.

imshow (*i*, *N*) displays a gray scale intensity image of *N* levels.

imshow (*r*, *g*, *b*) displays an RGB image.

The string **trueimage** can always be used as an optional final argument to prevent automatic zooming of the image.

ind2gray (<i>x</i> , <i>map</i>)	Function File
---	---------------

Convert an Octave indexed image to a gray scale intensity image. If *map* is omitted, the current colormap is used to determine the intensities.

$[r, g, b] = \mathbf{ind2rgb}$ (<i>x</i> , <i>map</i>)	Function File
--	---------------

Convert an indexed image to red, green, and blue color components. If *map* is omitted, the current colormap is used for the conversion.

$[x, map] = \mathbf{loadimage}$ (<i>file</i>)	Function File
---	---------------

Load an image file and its associated color map from the specified *file*. The image must be stored in Octave's image format.

rgb2ntsc (<i>rgb</i>)	Function File
--------------------------------	---------------

Image format conversion.

ntsc2rgb (<i>yi</i>)	Function File
-------------------------------	---------------

Image format conversion.

$rgb_map = \mathbf{hsv2rgb}$ (<i>hsv_map</i>)	Function File
---	---------------

Transform a colormap from the hsv space to the rgb space.

hsv_map = rgb2hsv (rgb_map) Function File

Transform a colormap from the rgb space to the hsv space.

A color in the RGB space consists of the red, green and blue intensities.

In the HSV space each color is represented by their hue, saturation and value (brightness). Value gives the amount of light in the color. Hue describes the dominant wavelength. Saturation is the amount of Hue mixed into the color.

ocean (n) Function File

Create color colormap. The argument *n* should be a scalar. If it is omitted, 64 is assumed.

[x, map] = rgb2ind (r, g, b) Function File

Convert an RGB image to an Octave indexed image.

saveimage (file, x, fmt, map) Function File

Save the matrix *x* to *file* in image format *fmt*. Valid values for *fmt* are

"img" Octave's image format. The current colormap is also saved in the file.

"ppm" Portable pixmap format.

"ps" PostScript format. Note that images saved in PostScript format can not be read back into Octave with loadimage.

If the fourth argument is supplied, the specified colormap will also be saved along with the image.

Note: if the colormap contains only two entries and these entries are black and white, the bitmap ppm and PostScript formats are used. If the image is a gray scale image (the entries within each row of the colormap are equal) the gray scale ppm and PostScript image formats are used, otherwise the full color formats are used.

IMAGEPATH Built-in Variable

A colon separated list of directories in which to search for image files.

32 Audio Processing

Octave provides a few functions for dealing with audio data. An audio ‘sample’ is a single output value from an A/D converter, i.e., a small integer number (usually 8 or 16 bits), and audio data is just a series of such samples. It can be characterized by three parameters: the sampling rate (measured in samples per second or Hz, e.g. 8000 or 44100), the number of bits per sample (e.g. 8 or 16), and the number of channels (1 for mono, 2 for stereo, etc.).

There are many different formats for representing such data. Currently, only the two most popular, *linear encoding* and *mu-law encoding*, are supported by Octave. There is an excellent FAQ on audio formats by Guido van Rossum <guido@cwi.nl> which can be found at any FAQ ftp site, in particular in the directory ‘/pub/usenet/news.answers/audio-fmts’ of the archive site `rtfm.mit.edu`.

Octave simply treats audio data as vectors of samples (non-mono data are not supported yet). It is assumed that audio files using linear encoding have one of the extensions ‘`lin`’ or ‘`raw`’, and that files holding data in mu-law encoding end in ‘`au`’, ‘`mu`’, or ‘`snd`’.

lin2mu (*x*, *n*) Function File

Converts audio data from linear to mu-law. Mu-law values use 8-bit unsigned integers. Linear values use *n*-bit signed integers or floating point values in the range $-1 \leq x \leq 1$ if *n* is 0. If *n* is not specified it defaults to 0, 8 or 16 depending on the range values in *x*.

mu2lin (*x*, *bps*) Function File

Converts audio data from linear to mu-law. Mu-law values are 8-bit unsigned integers. Linear values use *n*-bit signed integers or floating point values in the range $-1 \leq y \leq 1$ if *n* is 0. If *n* is not specified it defaults to 8.

loadaudio (*name*, *ext*, *bps*) Function File

Loads audio data from the file ‘*name.ext*’ into the vector *x*.

The extension *ext* determines how the data in the audio file is interpreted; the extensions ‘`lin`’ (default) and ‘`raw`’ correspond to linear, the extensions ‘`au`’, ‘`mu`’, or ‘`snd`’ to mu-law encoding.

The argument *bps* can be either 8 (default) or 16, and specifies the number of bits per sample used in the audio file.

saveaudio (*name*, *x*, *ext*, *bps*) Function File

Saves a vector *x* of audio data to the file ‘*name.ext*’. The optional parameters *ext* and *bps* determine the encoding and the number of bits per sample used in the audio file (see `loadaudio`); defaults are ‘`lin`’ and 8, respectively.

The following functions for audio I/O require special A/D hardware and operating system support. It is assumed that audio data in linear encoding can be played and recorded by reading from and writing to ‘`/dev/dsp`’, and that similarly ‘`/dev/audio`’ is used for mu-law encoding. These file names are system-dependent. Improvements so that these functions will work without modification on a wide variety of hardware are welcome.

- playaudio** (*name*, *ext*) Function File
playaudio (*x*) Function File
Plays the audio file '*name.ext*' or the audio data stored in the vector *x*.
- record** (*sec*, *sampling_rate*) Function File
Records *sec* seconds of audio input into the vector *x*. The default value for *sampling_rate* is 8000 samples per second, or 8kHz. The program waits until the user types RET and then immediately starts to record.
- setaudio** ([*w_type* [, *value*]]) Function File
executes the shell command 'mixer [*w_type* [, *value*]]'

33 Quaternions

Quaternions are hypercomplex numbers used to represent spatial rotations in three dimensions. This set of routines provides a useful basis for working with quaternions in Octave. A tutorial is in the Octave source, scripts/quaternion/quaternion.ps.

These functions were written by A. S. Hodel, Associate Professor, Auburn University.

<code>[a, b, c, d] = quaternion (w)</code>	Function File
<code>[vv, theta] = quaternion (w)</code>	Function File
<code>w = quaternion (a, b, c, d)</code>	Function File
<code>w = quaternion (vv, theta)</code>	Function File

Construct or extract a quaternion
 $w = a*i + b*j + c*k + d$
 from given data.

<code>qconj (q)</code>	Function File
------------------------	---------------

Conjugate of a quaternion.

$$q = [w, x, y, z] = w*i + x*j + y*k + z$$

$$qconj (q) = -w*i -x*j -y*k + z$$

<code>qderiv (omega)</code>	Function File
-----------------------------	---------------

Derivative of a quaternion.

Let Q be a quaternion to transform a vector from a fixed frame to a rotating frame. If the rotating frame is rotating about the [x, y, z] axes at angular rates [wx, wy, wz], then the derivative of Q is given by

$$Q' = qderivmat (omega) * Q$$

If the passive convention is used (rotate the frame, not the vector), then

$$Q' = -qderivmat (omega) * Q$$

<code>qderivmat (omega)</code>	Function File
--------------------------------	---------------

Derivative of a quaternion.

Let Q be a quaternion to transform a vector from a fixed frame to a rotating frame. If the rotating frame is rotating about the [x, y, z] axes at angular rates [wx, wy, wz], then the derivative of Q is given by

$$Q' = qderivmat (omega) * Q$$

If the passive convention is used (rotate the frame, not the vector), then

$$Q' = -qderivmat (omega) * Q.$$

<code>qinv (q)</code>	Function File
-----------------------	---------------

Return the inverse of a quaternion.

$$q = [w, x, y, z] = w*i + x*j + y*k + z$$

$$qmult (q, qinv (q)) = 1 = [0 0 0 1]$$

qmult (*a*, *b*) Function File

Multiply two quaternions.

$$[w, x, y, z] = w*i + x*j + y*k + z$$

identities:

$$\begin{array}{ll} i^2 = j^2 = k^2 = -1 & \\ ij = k & jk = i \\ ki = j & kj = -i \\ ji = -k & ik = -j \end{array}$$

qtrans (*v*, *q*) Function File

Transform the unit quaternion *v* by the unit quaternion *q*. Returns $v = q*v/q$.

qtransv (*v*, *q*) Function File

Transform the 3-D vector *v* by the unit quaternion *q*. Return a column vector.

$$\begin{aligned} vi = & (2*\text{real}(q)^2 - 1)*vb + 2*\text{imag}(q)*(imag(q)'*vb) \\ & + 2*\text{real}(q)*\text{cross}(imag(q), vb) \end{aligned}$$

Where $\text{imag}(q)$ is a column vector of length 3.

qtransvmat (*qib*) Function File

Construct a 3x3 transformation matrix from quaternion *qib* that is equivalent to rotation of *th* radians about axis *vv*, where $[vv, th] = \text{quaternion}(qib)$.

qcoordinate_plot (*qf*, *qb*, *qv*) Function File

Plot in the current figure a set of coordinate axes as viewed from the orientation specified by quaternion *qv*. Inertial axes are also plotted:

qf Quaternion from reference (x,y,z) to inertial.

qb Quaternion from reference to body.

qv Quaternion from reference to view angle.

34 System Utilities

This chapter describes the functions that are available to allow you to get information about what is happening outside of Octave, while it is still running, and use this information in your program. For example, you can get information about environment variables, the current time, and even start other programs from the Octave prompt.

34.1 Timing Utilities

Octave's core set of functions for manipulating time values are patterned after the corresponding functions from the standard C library. Several of these functions use a data structure for time that includes the following elements:

<code>usec</code>	Microseconds after the second (0-999999).
<code>sec</code>	Seconds after the minute (0-61). This number can be 61 to account for leap seconds.
<code>min</code>	Minutes after the hour (0-59).
<code>hour</code>	Hours since midnight (0-23).
<code>mday</code>	Day of the month (1-31).
<code>mon</code>	Months since January (0-11).
<code>year</code>	Years since 1900.
<code>wday</code>	Days since Sunday (0-6).
<code>yday</code>	Days since January 1 (0-365).
<code>isdst</code>	Daylight Savings Time flag.
<code>zone</code>	Time zone.

In the descriptions of the following functions, this structure is referred to as a *tm_struct*.

time () Loadable Function

Return the current time as the number of seconds since the epoch. The epoch is referenced to 00:00:00 CUT (Coordinated Universal Time) 1 Jan 1970. For example, on Monday February 17, 1997 at 07:15:06 CUT, the value returned by `time` was 856163706.

ctime (*t*) Function File

Convert a value returned from `time` (or any other nonnegative integer), to the local time and return a string of the same form as `asctime`. The function `ctime (time)` is equivalent to `asctime (localtime (time))`. For example,

```
ctime (time ())
⇒ "Mon Feb 17 01:15:06 1997\n"
```

gmtime (*t*) Loadable Function

Given a value returned from `time` (or any nonnegative integer), return a time structure corresponding to CUT. For example,

```
gmtime (time ())
⇒ {
    usec = 0
    year = 97
    mon = 1
    mday = 17
    sec = 6
    zone = CST
    min = 15
    wday = 1
    hour = 7
    isdst = 0
    yday = 47
}
```

localtime (*t*) Loadable Function

Given a value returned from `time` (or any nonnegative integer), return a time structure corresponding to the local time zone.

```
localtime (time ())
⇒ {
    usec = 0
    year = 97
    mon = 1
    mday = 17
    sec = 6
    zone = CST
    min = 15
    wday = 1
    hour = 1
    isdst = 0
    yday = 47
}
```

mktime (*tm_struct*) Loadable Function

Convert a time structure corresponding to the local time to the number of seconds since the epoch. For example,

```
mktime (localtime (time ()))
⇒ 856163706
```

asctime (*tm_struct*) Function File

Convert a time structure to a string using the following five-field format: Thu Mar 28 08:40:14 1996. For example,

```
asctime (localtime (time ()))
⇒ "Mon Feb 17 01:15:06 1997\n"
```

This is equivalent to `ctime (time ())`.

strftime (*tm_struct*)

Loadable Function

Format a time structure in a flexible way using ‘%’ substitutions similar to those in `printf`. Except where noted, substituted fields have a fixed size; numeric fields are padded if necessary. Padding is with zeros by default; for fields that display a single number, padding can be changed or inhibited by following the ‘%’ with one of the modifiers described below. Unknown field specifiers are copied as normal characters. All other characters are copied to the output without change. For example,

```
strftime ("%r (%Z) %A %e %B %Y", localtime (time ()))
⇒ "01:15:06 AM (CST) Monday 17 February 1997"
```

Octave’s `strftime` function supports a superset of the ANSI C field specifiers.

Literal character fields:

%	% character.
n	Newline character.
t	Tab character.

Numeric modifiers (a nonstandard extension):

- (dash)	Do not pad the field.
_ (underscore)	Pad the field with spaces.

Time fields:

%H	Hour (00-23).
%I	Hour (01-12).
%k	Hour (0-23).
%l	Hour (1-12).
%M	Minute (00-59).
%p	Locale’s AM or PM.
%r	Time, 12-hour (hh:mm:ss [AP]M).
%R	Time, 24-hour (hh:mm).
%s	Time in seconds since 00:00:00, Jan 1, 1970 (a nonstandard extension).
%S	Second (00-61).
%T	Time, 24-hour (hh:mm:ss).
%X	Locale’s time representation (%H:%M:%S).
%Z	Time zone (EDT), or nothing if no time zone is determinable.

Date fields:

%a	Locale's abbreviated weekday name (Sun-Sat).
%A	Locale's full weekday name, variable length (Sunday-Saturday).
%b	Locale's abbreviated month name (Jan-Dec).
%B	Locale's full month name, variable length (January-December).
%c	Locale's date and time (Sat Nov 04 12:02:33 EST 1989).
%C	Century (00-99).
%d	Day of month (01-31).
%e	Day of month (1-31).
%D	Date (mm/dd/yy).
%h	Same as %b.
%j	Day of year (001-366).
%m	Month (01-12).
%U	Week number of year with Sunday as first day of week (00-53).
%w	Day of week (0-6).
%W	Week number of year with Monday as first day of week (00-53).
%x	Locale's date representation (mm/dd/yy).
%y	Last two digits of year (00-99).
%Y	Year (1970-).

[*tm_struct*, *nchars*] = **strptime (*str*, *fmt*)** Loadable Function
 Convert the string *str* to a time structure under the control of the format *fmt*.

Most of the remaining functions described in this section are not patterned after the standard C library. Some are available for compatibility with MATLAB and others are provided because they are useful.

clock () Function File

Return a vector containing the current year, month (1-12), day (1-31), hour (0-23), minute (0-59) and second (0-61). For example,

```
clock ()
⇒ [ 1993, 8, 20, 4, 56, 1 ]
```

The function `clock` is more accurate on systems that have the `gettimeofday` function.

date () Function File

Return the date as a character string in the form DD-*MMM*-YY. For example,

```
date ()
⇒ "20-Aug-93"
```

etime (*t1*, *t2*) Function File

Return the difference (in seconds) between two time values returned from `clock`. For example:

```
t0 = clock ();
many computations later...
elapsed_time = etime (clock (), t0);
```

will set the variable `elapsed_time` to the number of seconds since the variable `t0` was set.

`[total, user, system] = cputime ();` Function File

Return the CPU time used by your Octave session. The first output is the total time spent executing your process and is equal to the sum of second and third outputs, which are the number of CPU seconds spent executing in user mode and the number of CPU seconds spent executing in system mode, respectively. If your system does not have a way to report CPU time usage, `cputime` returns 0 for each of its output values. Note that because Octave used some CPU time to start, it is reasonable to check to see if `cputime` works by checking to see if the total CPU time used is nonzero.

is_leap_year (*year*) Function File

Return 1 if the given year is a leap year and 0 otherwise. If no arguments are provided, `is_leap_year` will use the current year. For example,

```
is_leap_year (2000)
⇒ 1
```

tic () Function File

toc () Function File

These functions set and check a wall-clock timer. For example,

```
tic ();
many computations later...
elapsed_time = toc ();
```

will set the variable `elapsed_time` to the number of seconds since the most recent call to the function `tic`.

If you are more interested in the CPU time that your process used, you should use the `cputime` function instead. The `tic` and `toc` functions report the actual wall clock time that elapsed between the calls. This may include time spent processing other jobs or doing nothing at all. For example,

```
tic (); sleep (5); toc ()
⇒ 5
t = cputime (); sleep (5); cputime () - t
⇒ 0
```

(This example also illustrates that the CPU timer may have a fairly coarse resolution.)

pause (*seconds*) Built-in Function

Suspend the execution of the program. If invoked without any arguments, Octave waits until you type a character. With a numeric argument, it pauses for the given number of seconds. For example, the following statement prints a message and then waits 5 seconds before clearing the screen.

```
fprintf (stderr, "wait please...
");
pause (5);
clc;
```

sleep (*seconds*) Built-in Function

Suspend the execution of the program for the given number of seconds.

usleep (*microseconds*) Built-in Function

Suspend the execution of the program for the given number of microseconds. On systems where it is not possible to sleep for periods of time less than one second, **usleep** will pause the execution for `round (microseconds / 1e6)` seconds.

34.2 Filesystem Utilities

Octave includes the following functions for renaming and deleting files, creating, deleting, and reading directories, and for getting information about the status of files.

`[err, msg] = rename (old, new)` Built-in Function

Change the name of file *old* to *new*.

If successful, *err* is 0 and *msg* is an empty string. Otherwise, *err* is nonzero and *msg* contains a system-dependent error message.

`[err, msg] = link (old, new)` Built-in Function

Create a new link (also known as a hard link) to an existing file.

If successful, *err* is 0 and *msg* is an empty string. Otherwise, *err* is nonzero and *msg* contains a system-dependent error message.

`[err, msg] = symlink (old, new)` Built-in Function

Create a symbolic link *new* which contains the string *old*.

If successful, *err* is 0 and *msg* is an empty string. Otherwise, *err* is nonzero and *msg* contains a system-dependent error message.

`[result, err, msg] = readlink (symlink)` Built-in Function

Read the value of the symbolic link *symlink*.

If successful, *result* contains the contents of the symbolic link *symlink*, *err* is 0 and *msg* is an empty string. Otherwise, *err* is nonzero and *msg* contains a system-dependent error message.

`[err, msg] = unlink (file)` Built-in Function

Delete the file named *file*.

If successful, *err* is 0 and *msg* is an empty string. Otherwise, *err* is nonzero and *msg* contains a system-dependent error message.

`[files, err, msg] = readdir (dir)` Built-in Function

Return names of the files in the directory *dir* as a cell array of strings. If an error occurs, return an empty cell array in *files*.

If successful, *err* is 0 and *msg* is an empty string. Otherwise, *err* is nonzero and *msg* contains a system-dependent error message.

`[err, msg] = mkdir (dir)` Built-in Function

Create a directory named *dir*.

If successful, *err* is 0 and *msg* is an empty string. Otherwise, *err* is nonzero and *msg* contains a system-dependent error message.

`[err, msg] = rmdir (dir)` Built-in Function

Remove the directory named *dir*.

If successful, *err* is 0 and *msg* is an empty string. Otherwise, *err* is nonzero and *msg* contains a system-dependent error message.

`[err, msg] = mkfifo (name, mode)` Built-in Function

Create a *fifo* special file named *name* with file mode *mode*

If successful, *err* is 0 and *msg* is an empty string. Otherwise, *err* is nonzero and *msg* contains a system-dependent error message.

`umask (mask)` Built-in Function

Set the permission mask for file creation. The parameter *mask* is an integer, interpreted as an octal number. If successful, returns the previous value of the mask (as an integer to be interpreted as an octal number); otherwise an error message is printed.

`[info, err, msg] = stat (file)` Built-in Function

`[info, err, msg] = lstat (file)` Built-in Function

Return a structure *s* containing the following information about *file*.

dev ID of device containing a directory entry for this file.

ino File number of the file.

modestr File mode, as a string of ten letters or dashes as would be returned by `ls -l`.

nlink Number of links.

uid User ID of file's owner.

<code>gid</code>	Group ID of file's group.
<code>rdev</code>	ID of device for block or character special files.
<code>size</code>	Size in bytes.
<code>atime</code>	Time of last access in the same form as time values returned from <code>time</code> . See Section 34.1 [Timing Utilities], page 299.
<code>mtime</code>	Time of last modification in the same form as time values returned from <code>time</code> . See Section 34.1 [Timing Utilities], page 299.
<code>ctime</code>	Time of last file status change in the same form as time values returned from <code>time</code> . See Section 34.1 [Timing Utilities], page 299.
<code>blksize</code>	Size of blocks in the file.
<code>blocks</code>	Number of blocks allocated for file.

If the call is successful `err` is 0 and `msg` is an empty string. If the file does not exist, or some other error occurs, `s` is an empty matrix, `err` is `-1`, and `msg` contains the corresponding system error message.

If `file` is a symbolic link, `stat` will return information about the actual file the is referenced by the link. Use `lstat` if you want information about the symbolic link itself.

For example,

```
[s, err, msg] = stat ("/vmlinuz")
⇒ s =
    {
      atime = 855399756
      rdev = 0
      ctime = 847219094
      uid = 0
      size = 389218
      blksize = 4096
      mtime = 847219094
      gid = 6
      nlink = 1
      blocks = 768
      modestr = -rw-r--r--
      ino = 9316
      dev = 2049
    }
⇒ err = 0
⇒ msg =
```

glob (*pattern*)

Built-in Function

Given an array of strings in *pattern*, return a cell array of file names that match any of them, or an empty cell array if no patterns match. Tilde expansion is performed on each of the patterns before looking for matching file names. For example,

```
glob ("/vm*")
⇒ "/vmlinuz"
```

fnmatch (*pattern*, *string*) Built-in Function

Return 1 or zero for each element of *string* that matches any of the elements of the string array *pattern*, using the rules of filename pattern matching. For example,

```
fnmatch ("a*b", ["ab"; "axyzb"; "xyzab"])
⇒ [ 1; 1; 0 ]
```

file_in_path (*path*, *file*) Built-in Function

file_in_path (*path*, *file*, "all") Built-in Function

Return the absolute name of *file* if it can be found in *path*. The value of *path* should be a colon-separated list of directories in the format described for the built-in variable `LOADPATH`. If no file is found, return an empty matrix. For example,

```
file_in_path (LOADPATH, "nargchk.m")
⇒ "/usr/local/share/octave/2.0/m/general/nargchk.m"
```

If the second argument is a cell array of strings, search each directory of the path for element of the cell array and return the first that matches.

If the third optional argument "all" is supplied, return a cell array containing the list of all files that have the same name in the path. If no files are found, return an empty cell array.

tilde_expand (*string*) Built-in Function

Performs tilde expansion on *string*. If *string* begins with a tilde character, ('~'), all of the characters preceding the first slash (or all characters, if there is no slash) are treated as a possible user name, and the tilde and the following characters up to the slash are replaced by the home directory of the named user. If the tilde is followed immediately by a slash, the tilde is replaced by the home directory of the user running Octave. For example,

```
tilde_expand ("~joeuser/bin")
⇒ "/home/joeuser/bin"
tilde_expand ("~/bin")
⇒ "/home/jwe/bin"
```

34.3 Controlling Subprocesses

Octave includes some high-level commands like `system` and `popen` for starting subprocesses. If you want to run another program to perform some task and then look at its output, you will probably want to use these functions.

Octave also provides several very low-level Unix-like functions which can also be used for starting subprocesses, but you should probably only use them if you can't find any way to do what you need with the higher-level functions.

system (*string*, *return_output*, *type*) Built-in Function

Execute a shell command specified by *string*. The second argument is optional. If *type* is "async", the process is started in the background and the process id of the child process is returned immediately. Otherwise, the process is started, and Octave waits until it exits. If *type* argument is omitted, a value of "sync" is assumed.

If two input arguments are given (the actual value of *return_output* is irrelevant) and the subprocess is started synchronously, or if *system* is called with one input argument and one or more output arguments, the output from the command is returned. Otherwise, if the subprocess is executed synchronously, its output is sent to the standard output. To send the output of a command executed with *system* through the pager, use a command like

```
disp (system (cmd, 1));
```

or

```
printf ("%s\n", system (cmd, 1));
```

The *system* function can return two values. The first is any output from the command that was written to the standard output stream, and the second is the output status of the command. For example,

```
[output, status] = system ("echo foo; exit 2");
```

will set the variable *output* to the string 'foo', and the variable *status* to the integer '2'.

fid = **popen** (*command*, *mode*) Built-in Function

Start a process and create a pipe. The name of the command to run is given by *command*. The file identifier corresponding to the input or output stream of the process is returned in *fid*. The argument *mode* may be

"r" The pipe will be connected to the standard output of the process, and open for reading.

"w" The pipe will be connected to the standard input of the process, and open for writing.

For example,

```
fid = popen ("ls -ltr / | tail -3", "r");
while (isstr (s = fgets (fid)))
  fputs (stdout, s);
endwhile
+ drwxr-xr-x  33 root  root  3072 Feb 15 13:28 etc
+ drwxr-xr-x   3 root  root  1024 Feb 15 13:28 lib
+ drwxrwxrwt 15 root  root  2048 Feb 17 14:53 tmp
```

pclose (*fid*) Built-in Function

Close a file identifier that was opened by *popen*. You may also use *fclose* for the same purpose.

[*in*, *out*, *pid*] = **popen2** (*command*, *args*) Function File

Start a subprocess with two-way communication. The name of the process is given by *command*, and *args* is an array of strings containing options for the command. The file identifiers for the input and output streams of the subprocess are returned

in *in* and *out*. If execution of the command is successful, *pid* contains the process ID of the subprocess. Otherwise, *pid* is -1 .

For example,

```
[in, out, pid] = popen2 ("sort", "-nr");
fputs (in, "these\nare\nsome\nstrings\n");
fclose (in);
while (isstr (s = fgets (out)))
  fputs (stdout, s);
endwhile
fclose (out);
+ are
+ some
+ strings
+ these
```

EXEC_PATH

Built-in Variable

The variable `EXEC_PATH` is a colon separated list of directories to search when executing external programs. Its initial value is taken from the environment variable `OCTAVE_EXEC_PATH` (if it exists) or `PATH`, but that value can be overridden by the command line argument `--exec-path PATH`, or by setting the value of `EXEC_PATH` in a startup script. If the value of `EXEC_PATH` begins (ends) with a colon, the directories

```
octave-home/libexec/octave/site/exec/arch
octave-home/libexec/octave/version/exec/arch
```

are prepended (appended) to `EXEC_PATH`, where *octave-home* is the top-level directory where all of Octave is installed (the default value is `/usr/local`). If you don't specify a value for `EXEC_PATH` explicitly, these special directories are prepended to your shell path.

In most cases, the following functions simply decode their arguments and make the corresponding Unix system calls. For a complete example of how they can be used, look at the definition of the function `popen2`.

`[pid, msg] = fork ()`

Built-in Function

Create a copy of the current process.

Fork can return one of the following values:

- > 0 You are in the parent process. The value returned from `fork` is the process id of the child process. You should probably arrange to wait for any child processes to exit.
- 0 You are in the child process. You can call `exec` to start another process. If that fails, you should probably call `exit`.
- < 0 The call to `fork` failed for some reason. You must take evasive action. A system dependent error message will be waiting in *msg*.

`[err, msg] = exec (file, args)` Built-in Function

Replace current process with a new process. Calling `exec` without first calling `fork` will terminate your current Octave process and replace it with the program named by `file`. For example,

```
exec ("ls" "-l")
```

will run `ls` and return you to your shell prompt.

If successful, `exec` does not return. If `exec` does return, `err` will be nonzero, and `msg` will contain a system-dependent error message.

`[file_ids, err, msg] = pipe ()` Built-in Function

Create a pipe and return the vector `file_ids`, which corresponding to the reading and writing ends of the pipe.

If successful, `err` is 0 and `msg` is an empty string. Otherwise, `err` is nonzero and `msg` contains a system-dependent error message.

`[fid, msg] = dup2 (old, new)` Built-in Function

Duplicate a file descriptor.

If successful, `fid` is greater than zero and contains the new file ID. Otherwise, `fid` is negative and `msg` contains a system-dependent error message.

`[pid, msg] = waitpid (pid, options)` Built-in Function

Wait for process `pid` to terminate. The `pid` argument can be:

- 1 Wait for any child process.
- 0 Wait for any child process whose process group ID is equal to that of the Octave interpreter process.
- > 0 Wait for termination of the child process with ID `pid`.

The `options` argument can be:

- 0 Wait until signal is received or a child process exits (this is the default if the `options` argument is missing).
- 1 Do not hang if status is not immediately available.
- 2 Report the status of any child processes that are stopped, and whose status has not yet been reported since they stopped.
- 3 Implies both 1 and 2.

If the returned value of `pid` is greater than 0, it is the process ID of the child process that exited. If an error occurs, `pid` will be less than zero and `msg` will contain a system-dependent error message.

`[err, msg] = fcntl (fid, request, arg)` Built-in Function
 Change the properties of the open file *fid*. The following values may be passed as *request*:

- `F_DUPFD` Return a duplicate file descriptor.
- `F_GETFD` Return the file descriptor flags for *fid*.
- `F_SETFD` Set the file descriptor flags for *fid*.
- `F_GETFL` Return the file status flags for *fid*. The following codes may be returned (some of the flags may be undefined on some systems).
 - `O_RDONLY` Open for reading only.
 - `O_WRONLY` Open for writing only.
 - `O_RDWR` Open for reading and writing.
 - `O_APPEND` Append on each write.
 - `O_NONBLOCK` Nonblocking mode.
 - `O_SYNC` Wait for writes to complete.
 - `O_ASYNC` Asynchronous I/O.
- `F_SETFL` Set the file status flags for *fid* to the value specified by *arg*. The only flags that can be changed are `O_APPEND` and `O_NONBLOCK`.

If successful, *err* is 0 and *msg* is an empty string. Otherwise, *err* is nonzero and *msg* contains a system-dependent error message.

34.4 Process, Group, and User IDs

`pgid = getpgrp ()` Built-in Function
 Return the process group id of the current process.

`pid = getpid ()` Built-in Function
 Return the process id of the current process.

`pid = getppid ()` Built-in Function
 Return the process id of the parent process.

`euid = geteuid ()` Built-in Function
 Return the effective user id of the current process.

uid = getuid () Built-in Function
 Return the real user id of the current process.

egid = getegid () Built-in Function
 Return the effective group id of the current process.

gid = getgid () Built-in Function
 Return the real group id of the current process.

34.5 Environment Variables

getenv (var) Built-in Function
 Return the value of the environment variable *var*. For example,
`getenv ("PATH")`
 returns a string containing the value of your path.

putenv (var, value) Built-in Function
 Set the value of the environment variable *var* to *value*.

34.6 Current Working Directory

cd dir Command

chdir dir Command

Change the current working directory to *dir*. If *dir* is omitted, the current directory is changed to the users home directory. For example,

```
cd ~/octave
```

Changes the current working directory to ‘~/octave’. If the directory does not exist, an error message is printed and the working directory is not changed.

ls options Command

List directory contents. For example,

```
ls -l
+ total 12
+ -rw-r--r--  1 jwe  users  4488 Aug 19 04:02 foo.m
+ -rw-r--r--  1 jwe  users  1315 Aug 17 23:14 bar.m
```

The `dir` and `ls` commands are implemented by calling your system’s directory listing command, so the available options may vary from system to system.

pwd () Built-in Function
 Return the current working directory.

34.7 Password Database Functions

Octave's password database functions return information in a structure with the following fields.

name	The user name.
passwd	The encrypted password, if available.
uid	The numeric user id.
gid	The numeric group id.
gecos	The GECOS field.
dir	The home directory.
shell	The initial shell.

In the descriptions of the following functions, this data structure is referred to as a *pw_struct*.

pw_struct = **getpwent** () Loadable Function
Return a structure containing an entry from the password database, opening it if necessary. Once the end of the data has been reached, **getpwent** returns 0.

pw_struct = **getpwuid** (*uid*). Loadable Function
Return a structure containing the first entry from the password database with the user ID *uid*. If the user ID does not exist in the database, **getpwuid** returns 0.

pw_struct = **getpwnam** (*name*) Loadable Function
Return a structure containing the first entry from the password database with the user name *name*. If the user name does not exist in the database, **getpwnam** returns 0.

setpwent () Loadable Function
Return the internal pointer to the beginning of the password database.

endpwent () Loadable Function
Close the password database.

34.8 Group Database Functions

Octave's group database functions return information in a structure with the following fields.

name	The user name.
passwd	The encrypted password, if available.
gid	The numeric group id.
mem	The members of the group.

In the descriptions of the following functions, this data structure is referred to as a *grp_struct*.

grp_struct = **getgrent** () Loadable Function
 Return an entry from the group database, opening it if necessary. Once the end of the data has been reached, **getgrent** returns 0.

grp_struct = **getgrgid** (*gid*). Loadable Function
 Return the first entry from the group database with the group ID *gid*. If the group ID does not exist in the database, **getgrgid** returns 0.

grp_struct = **getgrnam** (*name*) Loadable Function
 Return the first entry from the group database with the group name *name*. If the group name does not exist in the database, **getgrname** returns 0.

setgrent () Loadable Function
 Return the internal pointer to the beginning of the group database.

endgrent () Loadable Function
 Close the group database.

34.9 System Information

computer () Function File
 Print or return a string of the form *cpu-vendor-os* that identifies the kind of computer Octave is running on. If invoked with an output argument, the value is returned instead of printed. For example,

```
computer ()
+ i586-pc-linux-gnu

x = computer ()
⇒ x = "i586-pc-linux-gnu"
```

isieee () Built-in Function
Return 1 if your computer claims to conform to the IEEE standard for floating point calculations.

OCTAVE_VERSION Built-in Variable
The version number of Octave, as a string.

octave_config_info (*option*) Built-in Function
Return a structure containing configuration and installation information for Octave. If *option* is a string, return the configuration information for the specified option.

getrusage () Loadable Function
Return a structure containing a number of statistics about the current Octave process. Not all fields are available on all systems. If it is not possible to get CPU time statistics, the CPU time slots are set to zero. Other missing data are replaced by NaN. Here is a list of all the possible fields that can be present in the structure returned by **getrusage**:

idrss	Unshared data size.
inblock	Number of block input operations.
isrss	Unshared stack size.
ixrss	Shared memory size.
majflt	Number of major page faults.
maxrss	Maximum data size.
minflt	Number of minor page faults.
msgrcv	Number of messages received.
msgsnd	Number of messages sent.
nivcsw	Number of involuntary context switches.
nsignals	Number of signals received.
nswap	Number of swaps.
nvcs	Number of voluntary context switches.
oublock	Number of block output operations.
stime	A structure containing the system CPU time used. The structure has the elements sec (seconds) usec (microseconds).
utime	A structure containing the user CPU time used. The structure has the elements sec (seconds) usec (microseconds).

Appendix A Tips and Standards

This chapter describes no additional features of Octave. Instead it gives advice on making effective use of the features described in the previous chapters.

A.1 Writing Clean Octave Programs

Here are some tips for avoiding common errors in writing Octave code intended for widespread use:

- Since all global variables share the same name space, and all functions share another name space, you should choose a short word to distinguish your program from other Octave programs. Then take care to begin the names of all global variables, constants, and functions with the chosen prefix. This helps avoid name conflicts.

If you write a function that you think ought to be added to Octave under a certain name, such as `fiddle_matrix`, don't call it by that name in your program. Call it `mylib_fiddle_matrix` in your program, and send mail to `bug-octave@bevo.che.wisc.edu` suggesting that it be added to Octave. If and when it is, the name can be changed easily enough.

If one prefix is insufficient, your package may use two or three alternative common prefixes, so long as they make sense.

Separate the prefix from the rest of the symbol name with an underscore `'_'`. This will be consistent with Octave itself and with most Octave programs.

- When you encounter an error condition, call the function `error` (or `usage`). The `error` and `usage` functions do not return. See Section 2.5 [Errors], page 24.
- Please put a copyright notice on the file if you give copies to anyone. Use the same lines that appear at the top of the function files distributed with Octave. If you have not signed papers to assign the copyright to anyone else, then place your name in the copyright notice.

A.2 Tips for Making Code Run Faster.

Here are some ways of improving the execution speed of Octave programs.

- Avoid looping wherever possible.
- Use iteration rather than recursion whenever possible. Function calls are slow in Octave.
- Avoid resizing matrices unnecessarily. When building a single result matrix from a series of calculations, set the size of the result matrix first, then insert values into it. Write

```

result = zeros (big_n, big_m)
for i = over:and_over
    r1 = ...
    r2 = ...
    result (r1, r2) = new_value ();
endfor

```

instead of

```

result = [];
for i = ever:and_ever
    result = [ result, new_value() ];
endfor

```

- Avoid calling `eval` or `feval` whenever possible, because they require Octave to parse input or look up the name of a function in the symbol table.

If you are using `eval` as an exception handling mechanism and not because you need to execute some arbitrary text, use the `try` statement instead. See Section 12.9 [The try Statement], page 88.

- If you are calling lots of functions but none of them will need to change during your run, set the variable `ignore_function_time_stamp` to "all" so that Octave doesn't waste a lot of time checking to see if you have updated your function files.

A.3 Tips for Documentation Strings

Here are some tips for the writing of documentation strings.

- Every command, function, or variable intended for users to know about should have a documentation string.
- An internal variable or subroutine of an Octave program might as well have a documentation string.
- The first line of the documentation string should consist of one or two complete sentences that stand on their own as a summary.

The documentation string can have additional lines that expand on the details of how to use the function or variable. The additional lines should also be made up of complete sentences.

- For consistency, phrase the verb in the first sentence of a documentation string as an infinitive with "to" omitted. For instance, use "Return the frob of A and B." in preference to "Returns the frob of A and B." Usually it looks good to do likewise for the rest of the first paragraph. Subsequent paragraphs usually look better if they have proper subjects.
- Write documentation strings in the active voice, not the passive, and in the present tense, not the future. For instance, use "Return a list containing A and B." instead of "A list containing A and B will be returned."
- Avoid using the word "cause" (or its equivalents) unnecessarily. Instead of, "Cause Octave to display text in boldface," write just "Display text in boldface."
- Do not start or end a documentation string with whitespace.
- Format the documentation string so that it fits in an Emacs window on an 80-column screen. It is a good idea for most lines to be no wider than 60 characters.

However, rather than simply filling the entire documentation string, you can make it much more readable by choosing line breaks with care. Use blank lines between topics if the documentation string is long.

- **Do not** indent subsequent lines of a documentation string so that the text is lined up in the source code with the text of the first line. This looks nice in the source code, but looks bizarre when users view the documentation. Remember that the indentation before the starting double-quote is not part of the string!

- The documentation string for a variable that is a yes-or-no flag should start with words such as “Nonzero means...”, to make it clear that all nonzero values are equivalent and indicate explicitly what zero and nonzero mean.
- When a function’s documentation string mentions the value of an argument of the function, use the argument name in capital letters as if it were a name for that value. Thus, the documentation string of the operator / refers to its second argument as ‘DIVISOR’, because the actual argument name is `divisor`.

Also use all caps for meta-syntactic variables, such as when you show the decomposition of a list or vector into subunits, some of which may vary.

A.4 Tips on Writing Comments

Here are the conventions to follow when writing comments.

- ‘#’ Comments that start with a single sharp-sign, ‘#’, should all be aligned to the same column on the right of the source code. Such comments usually explain how the code on the same line does its job. In the Emacs mode for Octave, the `M-;` (`indent-for-comment`) command automatically inserts such a ‘#’ in the right place, or aligns such a comment if it is already present.
- ‘##’ Comments that start with two semicolons, ‘##’, should be aligned to the same level of indentation as the code. Such comments usually describe the purpose of the following lines or the state of the program at that point.

The indentation commands of the Octave mode in Emacs, such as `M-;` (`indent-for-comment`) and `TAB` (`octave-indent-line`) automatically indent comments according to these conventions, depending on the number of semicolons. See section “Manipulating Comments” in *The GNU Emacs Manual*.

A.5 Conventional Headers for Octave Functions

Octave has conventions for using special comments in function files to give information such as who wrote them. This section explains these conventions.

The top of the file should contain a copyright notice, followed by a block of comments that can be used as the help text for the function. Here is an example:

```
## Copyright (C) 1996, 1997 John W. Eaton
##
## This file is part of Octave.
##
## Octave is free software; you can redistribute it and/or
## modify it under the terms of the GNU General Public
## License as published by the Free Software Foundation;
## either version 2, or (at your option) any later version.
##
## Octave is distributed in the hope that it will be useful,
## but WITHOUT ANY WARRANTY; without even the implied
## warranty of MERCHANTABILITY or FITNESS FOR A PARTICULAR
## PURPOSE. See the GNU General Public License for more
```

```

## details.
##
## You should have received a copy of the GNU General Public
## License along with Octave; see the file COPYING. If not,
## write to the Free Software Foundation, 59 Temple Place -
## Suite 330, Boston, MA 02111-1307, USA.

## usage: [IN, OUT, PID] = popen2 (COMMAND, ARGS)
##
## Start a subprocess with two-way communication. COMMAND
## specifies the name of the command to start. ARGS is an
## array of strings containing options for COMMAND. IN and
## OUT are the file ids of the input and streams for the
## subprocess, and PID is the process id of the subprocess,
## or -1 if COMMAND could not be executed.
##
## Example:
##
## [in, out, pid] = popen2 ("sort", "-nr");
## fputs (in, "these\nare\nsome\nstrings\n");
## fclose (in);
## while (isstr (s = fgets (out)))
##   fputs (stdout, s);
## endwhile
## fclose (out);

```

Octave uses the first block of comments in a function file that do not appear to be a copyright notice as the help text for the file. For Octave to recognize the first comment block as a copyright notice, it must match the regular expression

```
^ Copyright (C).*\n\n This file is part of Octave.
```

or

```
^ Copyright (C).*\n\n This program is free softwar
```

(after stripping the leading comment characters). This is a fairly strict requirement, and may be relaxed somewhat in the future.

After the copyright notice and help text come several *header comment* lines, each beginning with ‘## *header-name*:’. For example,

```

## Author: jwe
## Keywords: subprocesses input-output
## Maintainer: jwe

```

Here is a table of the conventional possibilities for *header-name*:

‘Author’ This line states the name and net address of at least the principal author of the library.

```
## Author: John W. Eaton <jwe@bevo.che.wisc.edu>
```

‘Maintainer’

This line should contain a single name/address as in the Author line, or an address only, or the string ‘jwe’. If there is no maintainer line, the person(s)

in the Author field are presumed to be the maintainers. The example above is mildly bogus because the maintainer line is redundant.

The idea behind the `'Author'` and `'Maintainer'` lines is to make possible a function to “send mail to the maintainer” without having to mine the name out by hand.

Be sure to surround the network address with `<...>` if you include the person's full name as well as the network address.

`'Created'` This optional line gives the original creation date of the file. For historical interest only.

`'Version'` If you wish to record version numbers for the individual Octave program, put them in this line.

`'Adapted-By'`

In this header line, place the name of the person who adapted the library for installation (to make it fit the style conventions, for example).

`'Keywords'`

This line lists keywords. Eventually, it will be used by an apropos command to allow people will find your package when they're looking for things by topic area. To separate the keywords, you can use spaces, commas, or both.

Just about every Octave function ought to have the `'Author'` and `'Keywords'` header comment lines. Use the others if they are appropriate. You can also put in header lines with other header names—they have no standard meanings, so they can't do any harm.

Appendix B Known Causes of Trouble

This section describes known problems that affect users of Octave. Most of these are not Octave bugs per se—if they were, we would fix them. But the result for a user may be like the result of a bug.

Some of these problems are due to bugs in other software, some are missing features that are too much work to add, and some are places where people’s opinions differ as to what is best.

B.1 Actual Bugs We Haven’t Fixed Yet

- Output that comes directly from Fortran functions is not sent through the pager and may appear out of sequence with other output that is sent through the pager. One way to avoid this is to force pending output to be flushed before calling a function that will produce output from within Fortran functions. To do this, use the command

```
fflush (stdout)
```

Another possible workaround is to use the command

```
page_screen_output = "false"
```

to turn the pager off.

- If you get messages like

```
Input line too long
```

when trying to plot many lines on one graph, you have probably generated a plot command that is too large for `gnuplot`’s fixed-length buffer for commands. Splitting up the plot command doesn’t help because `replot` is implemented in `gnuplot` by simply appending the new plotting commands to the old command line and then evaluating it again.

You can demonstrate this ‘feature’ by running `gnuplot` and doing something like

```
plot sin (x), sin (x), sin (x), ... lots more ..., sin (x)
```

and then

```
replot sin (x), sin (x), sin (x), ... lots more ..., sin (x)
```

after repeating the `replot` command a few times, `gnuplot` will give you an error.

Also, it doesn’t help to use backslashes to enter a plot command over several lines, because the limit is on the overall command line length, once the backslashed lines are all pasted together.

Because of this, Octave tries to use as little of the command-line length as possible by using the shortest possible abbreviations for all the plot commands and options. Unfortunately, the length of the temporary file names is probably what is taking up the most space on the command line.

You can buy a little bit of command line space by setting the environment variable `TMPDIR` to be `."` before starting Octave, or you can increase the maximum command line length in `gnuplot` by changing the following limits in the file `plot.h` in the `gnuplot` distribution and recompiling `gnuplot`.

```
#define MAX_LINE_LEN 32768 /* originally 1024 */  
#define MAX_TOKENS 8192 /* originally 400 */
```

Of course, this doesn't really fix the problem, but it does make it much less likely that you will run into trouble unless you are putting a very large number of lines on a given plot.

A list of ideas for future enhancements is distributed with Octave. See the file 'PROJECTS' in the top level directory in the source distribution.

B.2 Reporting Bugs

Your bug reports play an essential role in making Octave reliable.

When you encounter a problem, the first thing to do is to see if it is already known. See Appendix B [Trouble], page 323. If it isn't known, then you should report the problem.

Reporting a bug may help you by bringing a solution to your problem, or it may not. In any case, the principal function of a bug report is to help the entire community by making the next version of Octave work better. Bug reports are your contribution to the maintenance of Octave.

In order for a bug report to serve its purpose, you must include the information that makes it possible to fix the bug.

If you have Octave working at all, the easiest way to prepare a complete bug report is to use the Octave function `bug_report`. When you execute this function, Octave will prompt you for a subject and then invoke the editor on a file that already contains all the configuration information. When you exit the editor, Octave will mail the bug report for you.

B.3 Have You Found a Bug?

If you are not sure whether you have found a bug, here are some guidelines:

- If Octave gets a fatal signal, for any input whatever, that is a bug. Reliable interpreters never crash.
- If Octave produces incorrect results, for any input whatever, that is a bug.
- Some output may appear to be incorrect when it is in fact due to a program whose behavior is undefined, which happened by chance to give the desired results on another system. For example, the range operator may produce different results because of differences in the way floating point arithmetic is handled on various systems.
- If Octave produces an error message for valid input, that is a bug.
- If Octave does not produce an error message for invalid input, that is a bug. However, you should note that your idea of "invalid input" might be my idea of "an extension" or "support for traditional practice".
- If you are an experienced user of programs like Octave, your suggestions for improvement are welcome in any case.

B.4 Where to Report Bugs

If you have Octave working at all, the easiest way to prepare a complete bug report is to use the Octave function `bug_report`. When you execute this function, Octave will prompt you for a subject and then invoke the editor on a file that already contains all the configuration information. When you exit the editor, Octave will mail the bug report for you.

If for some reason you cannot use Octave's `bug_report` function, send bug reports for Octave to `bug-octave@bevo.che.wisc.edu`.

Do not send bug reports to 'help-octave'. Most users of Octave do not want to receive bug reports. Those that do have asked to be on the mailing list.

As a last resort, send bug reports on paper to:

Octave Bugs c/o John W. Eaton
University of Wisconsin-Madison
Department of Chemical Engineering
1415 Engineering Drive
Madison, Wisconsin 53706 USA

B.5 How to Report Bugs

Send bug reports for Octave to one of the addresses listed in Section B.4 [Bug Lists], page 325.

The fundamental principle of reporting bugs usefully is this: **report all the facts**. If you are not sure whether to state a fact or leave it out, state it!

Often people omit facts because they think they know what causes the problem and they conclude that some details don't matter. Thus, you might assume that the name of the variable you use in an example does not matter. Well, probably it doesn't, but one cannot be sure. Perhaps the bug is a stray memory reference which happens to fetch from the location where that name is stored in memory; perhaps, if the name were different, the contents of that location would fool the interpreter into doing the right thing despite the bug. Play it safe and give a specific, complete example.

Keep in mind that the purpose of a bug report is to enable someone to fix the bug if it is not known. Always write your bug reports on the assumption that the bug is not known.

Sometimes people give a few sketchy facts and ask, "Does this ring a bell?" This cannot help us fix a bug. It is better to send a complete bug report to begin with.

Try to make your bug report self-contained. If we have to ask you for more information, it is best if you include all the previous information in your response, as well as the information that was missing.

To enable someone to investigate the bug, you should include all these things:

- The version of Octave. You can get this by noting the version number that is printed when Octave starts, or running it with the `'-v'` option.
- A complete input file that will reproduce the bug.

A single statement may not be enough of an example—the bug might depend on other details that are missing from the single statement where the error finally occurs.

- The command arguments you gave Octave to execute that example and observe the bug. To guarantee you won't omit something important, list all the options.

If we were to try to guess the arguments, we would probably guess wrong and then we would not encounter the bug.

- The type of machine you are using, and the operating system name and version number.
- The command-line arguments you gave to the `configure` command when you installed the interpreter.

- A complete list of any modifications you have made to the interpreter source.

Be precise about these changes—show a context diff for them.

- Details of any other deviations from the standard procedure for installing Octave.
- A description of what behavior you observe that you believe is incorrect. For example, "The interpreter gets a fatal signal," or, "The output produced at line 208 is incorrect."

Of course, if the bug is that the interpreter gets a fatal signal, then one can't miss it. But if the bug is incorrect output, we might not notice unless it is glaringly wrong.

Even if the problem you experience is a fatal signal, you should still say so explicitly. Suppose something strange is going on, such as, your copy of the interpreter is out of synch, or you have encountered a bug in the C library on your system. Your copy might crash and the copy here would not. If you said to expect a crash, then when the interpreter here fails to crash, we would know that the bug was not happening. If you don't say to expect a crash, then we would not know whether the bug was happening. We would not be able to draw any conclusion from our observations.

Often the observed symptom is incorrect output when your program is run. Unfortunately, this is not enough information unless the program is short and simple. It is very helpful if you can include an explanation of the expected output, and why the actual output is incorrect.

- If you wish to suggest changes to the Octave source, send them as context diffs. If you even discuss something in the Octave source, refer to it by context, not by line number, because the line numbers in the development sources probably won't match those in your sources.

Here are some things that are not necessary:

- A description of the envelope of the bug.

Often people who encounter a bug spend a lot of time investigating which changes to the input file will make the bug go away and which changes will not affect it. Such information is usually not necessary to enable us to fix bugs in Octave, but if you can find a simpler example to report *instead* of the original one, that is a convenience. Errors in the output will be easier to spot, running under the debugger will take less time, etc. Most Octave bugs involve just one function, so the most straightforward way to simplify an example is to delete all the function definitions except the one in which the bug occurs.

However, simplification is not vital; if you don't want to do this, report the bug anyway and send the entire test case you used.

- A patch for the bug. Patches can be helpful, but if you find a bug, you should report it, even if you cannot send a fix for the problem.

B.6 Sending Patches for Octave

If you would like to write bug fixes or improvements for Octave, that is very helpful. When you send your changes, please follow these guidelines to avoid causing extra work for us in studying the patches.

If you don't follow these guidelines, your information might still be useful, but using it will take extra work. Maintaining Octave is a lot of work in the best of circumstances, and we can't keep up unless you do your best to help.

- Send an explanation with your changes of what problem they fix or what improvement they bring about. For a bug fix, just include a copy of the bug report, and explain why the change fixes the bug.
- Always include a proper bug report for the problem you think you have fixed. We need to convince ourselves that the change is right before installing it. Even if it is right, we might have trouble judging it if we don't have a way to reproduce the problem.
- Include all the comments that are appropriate to help people reading the source in the future understand why this change was needed.
- Don't mix together changes made for different reasons. Send them *individually*.

If you make two changes for separate reasons, then we might not want to install them both. We might want to install just one.

- Use 'diff -c' to make your diffs. Diffs without context are hard for us to install reliably. More than that, they make it hard for us to study the diffs to decide whether we want to install them. Unidiff format is better than contextless diffs, but not as easy to read as '-c' format.

If you have GNU diff, use 'diff -cp', which shows the name of the function that each change occurs in.

- Write the change log entries for your changes.

Read the 'ChangeLog' file to see what sorts of information to put in, and to learn the style that we use. The purpose of the change log is to show people where to find what was changed. So you need to be specific about what functions you changed; in large functions, it's often helpful to indicate where within the function the change was made.

On the other hand, once you have shown people where to find the change, you need not explain its purpose. Thus, if you add a new function, all you need to say about it is that it is new. If you feel that the purpose needs explaining, it probably does—but the explanation will be much more useful if you put it in comments in the code.

If you would like your name to appear in the header line for who made the change, send us the header line.

B.7 How To Get Help with Octave

The mailing list `help-octave@bevo.che.wisc.edu` exists for the discussion of matters related to using and installing Octave. If you would like to join the discussion, please send a short note to `help-octave-request@bevo.che.wisc.edu`.

Please do not send requests to be added or removed from the mailing list, or other administrative trivia to the list itself.

If you think you have found a bug in the installation procedure, however, you should send a complete bug report for the problem to `bug-octave@bevo.che.wisc.edu`. See Section B.5 [Bug Reporting], page 325, for information that will help you to submit a useful report.

Appendix C Installing Octave

Here is the procedure for installing Octave from scratch on a Unix system.

- Run the shell script ‘`configure`’. This will determine the features your system has (or doesn’t have) and create a file named ‘`Makefile`’ from each of the files named ‘`Makefile.in`’.

Here is a summary of the configure options that are most frequently used when building Octave:

`--prefix=prefix`

Install Octave in subdirectories below *prefix*. The default value of *prefix* is ‘`/usr/local`’.

`--srcdir=dir`

Look for Octave sources in the directory *dir*.

`--with-f2c`

Use `f2c` even if a Fortran compiler is available.

`--with-f77`

Use `f77` to compile Fortran code. You may also specify the name of the compiler to use as an optional argument. For example, `--with-f77=g77` sets the name of the Fortran compiler to `g77`.

`--enable-shared`

Create shared libraries. If you are planning to use `--enable-lite-kernel` or the dynamic loading features, you will probably want to use this option. It will make your ‘`.oct`’ files much smaller and on some systems it may be necessary to build shared libraries in order to use dynamically linked functions.

You may also want to build a shared version of `libstdc++`, if your system doesn’t already have one. Note that a patch is needed to build shared versions of version 2.7.2 of `libstdc++` on the HP-PA architecture. You can find the patch at <ftp://ftp.cygnum.com/pub/g++/libg++-2.7.2-hppa-gcc-fix>.

`--enable-dl`

Use `dlopen` and friends to make Octave capable of dynamically linking externally compiled functions. This only works on systems that actually have these functions. If you plan on using this feature, you should probably also use `--enable-shared` to reduce the size of your ‘`.oct`’ files.

`--enable-shl`

Use `shl_load` and friends to make Octave capable of dynamically linking externally compiled functions. This only works on systems that actually have these functions (only HP-UX systems). If you plan on using this feature, you should probably also use `--enable-shared` to reduce the size of your ‘`.oct`’ files.

--enable-lite-kernel

Compile smaller kernel. This currently requires the dynamic linking functions `dlopen` or `shl_load` and friends so that Octave can load functions at run time that are not loaded at compile time.

--without-blas

Compile and use the generic BLAS and LAPACK versions included with Octave. By default, configure first looks for BLAS and LAPACK matrix libraries on your system, including optimized BLAS implementations such as the free ATLAS 3.0, as well as vendor-tuned libraries. (The use of an optimized BLAS will generally result in several-times faster matrix operations.) Only use this option if your system has BLAS/LAPACK libraries that cause problems for some reason. You can also use **--with-blas=lib** to specify a particular BLAS library `-llib` that configure doesn't check for automatically.

--help Print a summary of the options recognized by the configure script.

See the file 'INSTALL' for more information about the command line options used by configure. That file also contains instructions for compiling in a directory other than where the source is located.

- Run make.

You will need a recent version of GNU Make. Modifying Octave's makefiles to work with other make programs is probably not worth your time. We recommend you get and compile GNU Make instead.

For plotting, you will need to have gnuplot installed on your system. Gnuplot is a command-driven interactive function plotting program. Gnuplot is copyrighted, but freely distributable. The 'gnu' in gnuplot is a coincidence—it is not related to the GNU project or the FSF in any but the most peripheral sense.

To compile Octave, you will need a recent version of GNU Make. You will also need g++ 2.7.2 or later. Version 2.8.0 or egcs 1.0.x should work. Later versions may work, but C++ is still evolving, so don't be too surprised if you run into some trouble.

It is no longer necessary to have `libg++`, but you do need to have the GNU implementation of `libstdc++`. If you are using g++ 2.7.2, `libstdc++` is distributed along with `libg++`, but for later versions, `libstdc++` is distributed separately. For egcs, `libstdc++` is included with the compiler distribution.

If you plan to modify the parser you will also need GNU `bison` and `flex`. If you modify the documentation, you will need GNU `Texinfo`, along with the patch for the `makeinfo` program that is distributed with Octave.

GNU Make, `gcc`, and `libstdc++`, `gnuplot`, `bison`, `flex`, and `Texinfo` are all available from many anonymous ftp archives. The primary site is <ftp.gnu.org>, but it is often very busy. A list of sites that mirror the software on <ftp.gnu.org> is available by anonymous ftp from <ftp://ftp.gnu.org/pub/gnu/GNUinfo/FTP>.

If you don't have a Fortran compiler, or if your Fortran compiler doesn't work like the traditional Unix `f77`, you will need to have the Fortran to C translator `f2c`. You can get `f2c` from any number of anonymous ftp archives. The most recent version of `f2c` is always available from netlib.att.com.

On an otherwise idle Pentium 133 running Linux, it will take somewhere between 1-1/2 to 3 hours to compile everything, depending on whether you are building shared libraries. You will need about 100 megabytes of disk storage to work with (considerably less if you don't compile with debugging symbols). To do that, use the command

```
make CFLAGS=-O CXXFLAGS=-O LDFLAGS=
```

instead of just `make`.

- If you encounter errors while compiling Octave, first check the list of known problems below to see if there is a workaround or solution for your problem. If not, see Appendix B [Trouble], page 323, for information about how to report bugs.

- Once you have successfully compiled Octave, run `make install`.

This will install a copy of octave, its libraries, and its documentation in the destination directory. As distributed, Octave is installed in the following directories. In the table below, *prefix* defaults to `/usr/local`, *version* stands for the current version number of the interpreter, and *arch* is the type of computer on which Octave is installed (for example, `i586-unknown-gnu`).

`prefix/bin`

Octave and other binaries that people will want to run directly.

`prefix/lib`

Libraries like `libcruft.a` and `liboctave.a`.

`prefix/share`

Architecture-independent data files.

`prefix/include/octave`

Include files distributed with Octave.

`prefix/man/man1`

Unix-style man pages describing Octave.

`prefix/info`

Info files describing Octave.

`prefix/share/octave/version/m`

Function files distributed with Octave. This includes the Octave version, so that multiple versions of Octave may be installed at the same time.

`prefix/lib/octave/version/exec/arch`

Executables to be run by Octave rather than the user.

`prefix/lib/octave/version/oct/arch`

Object files that will be dynamically loaded.

`prefix/share/octave/version/imagelib`

Image files that are distributed with Octave.

C.1 Installation Problems

This section contains a list of problems (and some apparent problems that don't really mean anything is wrong) that may show up during installation of Octave.

- On some SCO systems, `info` fails to compile if `HAVE_TERMIOS_H` is defined in `'config.h'`. Simply removing the definition from `'info/config.h'` should allow it to compile.
- If `configure` finds `dlopen`, `dlsym`, `dlclose`, and `dlerror`, but not the header file `'dlfcn.h'`, you need to find the source for the header file and install it in the directory `'usr/include'`. This is reportedly a problem with Slackware 3.1. For Linux/GNU systems, the source for `'dlfcn.h'` is in the `ldso` package.
- Building `' .oct'` files doesn't work.

You should probably have a shared version of `libstdc++`. A patch is needed to build shared versions of version 2.7.2 of `libstdc++` on the HP-PA architecture. You can find the patch at `ftp://ftp.cygnum.com/pub/g++/libg++-2.7.2-hppa-gcc-fix`.

- On some alpha systems there may be a problem with the `libdxml` library, resulting in floating point errors and/or segmentation faults in the linear algebra routines called by Octave. If you encounter such problems, then you should modify the `configure` script so that `SPECIAL_MATH_LIB` is not set to `-ldxml`.
- On FreeBSD systems Octave may hang while initializing some internal constants. The fix appears to be to use

```
options      GPL_MATH_EMULATE
```

rather than

```
options      MATH_EMULATE
```

in the kernel configuration files (typically found in the directory `'/sys/i386/conf'`). After making this change, you'll need to rebuild the kernel, install it, and reboot.

- If you encounter errors like

```
passing 'void (*)()' as argument 2 of
      'octave_set_signal_handler(int, void (*)(int))'
```

or

```
warning: ANSI C++ prohibits conversion from '(int)' to '(...)'
```

while compiling `'sighandlers.cc'`, you may need to edit some files in the `gcc` include subdirectory to add proper prototypes for functions there. For example, Ultrix 4.2 needs proper declarations for the `signal` function and the `SIG_IGN` macro in the file `'signal.h'`.

On some systems the `SIG_IGN` macro is defined to be something like this:

```
#define SIG_IGN (void (*)())1
```

when it should really be something like:

```
#define SIG_IGN (void (*)(int))1
```

to match the prototype declaration for the `signal` function. This change should also be made for the `SIG_DFL` and `SIG_ERR` symbols. It may be necessary to change the definitions in `'sys/signal.h'` as well.

The `gcc` `fixincludes` and `fixproto` scripts should probably fix these problems when `gcc` installs its modified set of header files, but I don't think that's been done yet.

You should not change the files in `'usr/include'`. You can find the `gcc` include directory tree by running the command

```
gcc -print-libgcc-file-name
```

The directory of `gcc` include files normally begins in the same directory that contains the file `'libgcc.a'`.

- Some of the Fortran subroutines may fail to compile with older versions of the Sun Fortran compiler. If you get errors like

```
zgemm.f:
zgemm:
warning: unexpected parent of complex expression subtree
zgemm.f, line 245: warning: unexpected parent of complex
expression subtree
warning: unexpected parent of complex expression subtree
zgemm.f, line 304: warning: unexpected parent of complex
expression subtree
warning: unexpected parent of complex expression subtree
zgemm.f, line 327: warning: unexpected parent of complex
expression subtree
pcc_binval: missing IR_CONV in complex op
make[2]: *** [zgemm.o] Error 1
```

when compiling the Fortran subroutines in the `'libcruft'` subdirectory, you should either upgrade your compiler or try compiling with optimization turned off.

- On NeXT systems, if you get errors like this:

```
/usr/tmp/cc007458.s:unknown:Undefined local symbol LBB7656
/usr/tmp/cc007458.s:unknown:Undefined local symbol LBE7656
```

when compiling `'Array.cc'` and `'Matrix.cc'`, try recompiling these files without `-g`.

- Some people have reported that calls to `shell_cmd` and the pager do not work on SunOS systems. This is apparently due to having `G_HAVE_SYS_WAIT` defined to be 0 instead of 1 when compiling `libg++`.
- On NeXT systems, linking to `'libsys_s.a'` may fail to resolve the following functions

```
_tcgetattr
_tcsetattr
_tcflow
```

which are part of `'libposix.a'`. Unfortunately, linking Octave with `-posix` results in the following undefined symbols.

```
.destructors_used
.constructors_used
_objc_msgSend
_NXGetDefaultValue
_NXRegisterDefaults
_objc_class_name_NXStringTable
_objc_class_name_NXBundle
```

One kluge around this problem is to extract `'termios.o'` from `'libposix.a'`, put it in Octave's `'src'` directory, and add it to the list of files to link together in the makefile. Suggestions for better ways to solve this problem are welcome!

- If Octave crashes immediately with a floating point exception, it is likely that it is failing to initialize the IEEE floating point values for infinity and NaN.

If your system actually does support IEEE arithmetic, you should be able to fix this problem by modifying the function `octave_ieee_init` in the file `lo-ieee.cc` to correctly initialize Octave's internal infinity and NaN variables.

If your system does not support IEEE arithmetic but Octave's configure script incorrectly determined that it does, you can work around the problem by editing the file `config.h` to not define `HAVE_ISINF`, `HAVE_FINITE`, and `HAVE_ISNAN`.

In any case, please report this as a bug since it might be possible to modify Octave's configuration script to automatically determine the proper thing to do.

- After installing the binary distribution of Octave in an alternate directory, the Emacs command `run-octave` doesn't work. Emacs hangs in `accept-process-output` in `inferior-octave-startup`.

This seems to be a problem with executing a shell script using the `comint` package. You can avoid the problem by changing the way Octave is installed to eliminate the need for the shell script. You can either compile and install Octave using the source distribution, reinstall the binary distribution in the default directory, or copy the commands in the octave shell script wrapper to your shell startup files (and the shell startup files for anyone else who is using Octave) and then rename the file `octave.bin` to be `octave`.

Appendix D Emacs Octave Support

The development of Octave code can greatly be facilitated using Emacs with Octave mode, a major mode for editing Octave files which can e.g. automatically indent the code, do some of the typing (with Abbrev mode) and show keywords, comments, strings, etc. in different faces (with Font-lock mode on devices that support it).

It is also possible to run Octave from within Emacs, either by directly entering commands at the prompt in a buffer in Inferior Octave mode, or by interacting with Octave from within a file with Octave code. This is useful in particular for debugging Octave code.

Finally, you can convince Octave to use the Emacs info reader for `help -i`.

All functionality is provided by the Emacs Lisp package EOS (for “Emacs Octave Support”). This chapter describes how to set up and use this package.

Please contact <Kurt.Hornik@ci.tuwien.ac.at> if you have any questions or suggestions on using EOS.

D.1 Installing EOS

The Emacs package EOS consists of the three files ‘`octave-mod.el`’, ‘`octave-inf.el`’, and ‘`octave-hlp.el`’. These files, or better yet their byte-compiled versions, should be somewhere in your Emacs load-path.

If you have GNU Emacs with a version number at least as high as 19.35, you are all set up, because EOS is respectively will be part of GNU Emacs as of version 19.35.

Otherwise, copy the three files from the ‘`emacs`’ subdirectory of the Octave distribution to a place where Emacs can find them (this depends on how your Emacs was installed). Byte-compile them for speed if you want.

D.2 Using Octave Mode

If you are lucky, your sysadmins have already arranged everything so that Emacs automatically goes into Octave mode whenever you visit an Octave code file as characterized by its extension ‘`.m`’. If not, proceed as follows.

1. To begin using Octave mode for all ‘`.m`’ files you visit, add the following lines to a file loaded by Emacs at startup time, typically your ‘`~/ .emacs`’ file:

```
(autoload 'octave-mode "octave-mod" nil t)
(setq auto-mode-alist
      (cons '("\\.m$" . octave-mode) auto-mode-alist))
```

2. Finally, to turn on the abbrevs, auto-fill and font-lock features automatically, also add the following lines to one of the Emacs startup files:

```
(add-hook 'octave-mode-hook
          (lambda ()
            (abbrev-mode 1)
            (auto-fill-mode 1)
            (if (eq window-system 'x)
                (font-lock-mode 1))))
```

See the Emacs manual for more information about how to customize Font-lock mode.

In Octave mode, the following special Emacs commands can be used in addition to the standard Emacs commands.

<i>C-h m</i>	Describe the features of Octave mode.
<i>LFD</i>	Reindent the current Octave line, insert a newline and indent the new line (<code>octave-reindent-then-newline-and-indent</code>). An abbrev before point is expanded if <code>abbrev-mode</code> is non- <code>nil</code> .
<i>TAB</i>	Indents current Octave line based on its contents and on previous lines (<code>indent-according-to-mode</code>).
<i>;</i>	Insert an “electric” semicolon (<code>octave-electric-semi</code>). If <code>octave-auto-indent</code> is non- <code>nil</code> , reindent the current line. If <code>octave-auto-newline</code> is non- <code>nil</code> , automatically insert a newline and indent the new line.
<i>‘</i>	Start entering an abbreviation (<code>octave-abbrev-start</code>). If Abbrev mode is turned on, typing <i>C-h</i> or <i>‘?</i> lists all abbrevs. Any other key combination is executed normally. Note that all Octave abbrevs start with a grave accent.
<i>M-LFD</i>	Break line at point and insert continuation marker and alignment (<code>octave-split-line</code>).
<i>M-TAB</i>	Perform completion on Octave symbol preceding point, comparing that symbol against Octave’s reserved words and builtin variables (<code>octave-complete-symbol</code>).
<i>M-C-a</i>	Move backward to the beginning of a function (<code>octave-beginning-of-defun</code>). With prefix argument <i>N</i> , do it that many times if <i>N</i> is positive; otherwise, move forward to the <i>N</i> -th following beginning of a function.
<i>M-C-e</i>	Move forward to the end of a function (<code>octave-end-of-defun</code>). With prefix argument <i>N</i> , do it that many times if <i>N</i> is positive; otherwise, move back to the <i>N</i> -th preceding end of a function.
<i>M-C-h</i>	Puts point at beginning and mark at the end of the current Octave function, i.e., the one containing point or following point (<code>octave-mark-defun</code>).
<i>M-C-q</i>	Properly indents the Octave function which contains point (<code>octave-indent-defun</code>).
<i>M-;</i>	If there is no comment already on this line, create a code-level comment (started by two comment characters) if the line is empty, or an in-line comment (started by one comment character) otherwise (<code>octave-indent-for-comment</code>). Point is left after the start of the comment which is properly aligned.
<i>C-c ;</i>	Puts the comment character <code>#</code> (more precisely, the string value of <code>octave-comment-start</code>) at the beginning of every line in the region (<code>octave-comment-region</code>). With just <i>C-u</i> prefix argument, uncomment each line in the region. A numeric prefix argument <i>N</i> means use <i>N</i> comment characters.
<i>C-c :</i>	Uncomments every line in the region (<code>octave-uncomment-region</code>).
<i>C-c C-p</i>	Move one line of Octave code backward, skipping empty and comment lines (<code>octave-previous-code-line</code>). With numeric prefix argument <i>N</i> , move that many code lines backward (forward if <i>N</i> is negative).

- C-c C-n** Move one line of Octave code forward, skipping empty and comment lines (`octave-next-code-line`). With numeric prefix argument *N*, move that many code lines forward (backward if *N* is negative).
- C-c C-a** Move to the ‘real’ beginning of the current line (`octave-beginning-of-line`). If point is in an empty or comment line, simply go to its beginning; otherwise, move backwards to the beginning of the first code line which is not inside a continuation statement, i.e., which does not follow a code line ending in ‘...’ or ‘\’, or is inside an open parenthesis list.
- C-c C-e** Move to the ‘real’ end of the current line (`octave-end-of-line`). If point is in a code line, move forward to the end of the first Octave code line which does not end in ‘...’ or ‘\’ or is inside an open parenthesis list. Otherwise, simply go to the end of the current line.
- C-c M-C-n** Move forward across one balanced begin-end block of Octave code (`octave-forward-block`). With numeric prefix argument *N*, move forward across *n* such blocks (backward if *N* is negative).
- C-c M-C-p** Move back across one balanced begin-end block of Octave code (`octave-backward-block`). With numeric prefix argument *N*, move backward across *N* such blocks (forward if *N* is negative).
- C-c M-C-d** Move forward down one begin-end block level of Octave code (`octave-down-block`). With numeric prefix argument, do it that many times; a negative argument means move backward, but still go down one level.
- C-c M-C-u** Move backward out of one begin-end block level of Octave code (`octave-backward-up-block`). With numeric prefix argument, do it that many times; a negative argument means move forward, but still to a less deep spot.
- C-c M-C-h** Put point at the beginning of this block, mark at the end (`octave-mark-block`). The block marked is the one that contains point or follows point.
- C-c]** Close the current block on a separate line (`octave-close-block`). An error is signaled if no block to close is found.
- C-c f** Insert a function skeleton, prompting for the function’s name, arguments and return values which have to be entered without parens (`octave-insert-defun`).
- C-c C-h** Search the function, operator and variable indices of all info files with documentation for Octave for entries (`octave-help`). If used interactively, the entry is prompted for with completion. If multiple matches are found, one can cycle through them using the standard ‘,’ (`Info-index-next`) command of the Info reader.

The variable `octave-help-files` is a list of files to search through and defaults to `'("octave")`. If there is also an Octave Local Guide with corresponding info file, say, `'octave-LG'`, you can have `octave-help` search both files by

```
(setq octave-help-files '("octave" "octave-LG"))
```

in one of your Emacs startup files.

A common problem is that the `(RET)` key does *not* indent the line to where the new text should go after inserting the newline. This is because the standard Emacs convention

is that `RET` (aka `C-m`) just adds a newline, whereas `LFD` (aka `C-j`) adds a newline and indents it. This is particularly inconvenient for users with keyboards which do not have a special `LFD` key at all; in such cases, it is typically more convenient to use `RET` as the `LFD` key (rather than typing `C-j`).

You can make `RET` do this by adding

```
(define-key octave-mode-map "\C-m"
  'octave-reindent-then-newline-and-indent)
```

to one of your Emacs startup files. Another, more generally applicable solution is

```
(defun RET-behaves-as-LFD ()
  (let ((x (key-binding "\C-j")))
    (local-set-key "\C-m" x)))
(add-hook 'octave-mode-hook 'RET-behaves-as-LFD)
```

(this works for all modes by adding to the startup hooks, without having to know the particular binding of `RET` in that mode!). Similar considerations apply for using `M-RET` as `M-LFD`. As Barry A. Warsaw <bwarshaw@cnri.reston.va.us> says in the documentation for his `cc-mode`, “This is a very common question. :-) If you want this to be the default behavior, don’t lobby me, lobby RMS!”

The following variables can be used to customize Octave mode.

`octave-auto-indent`

Non-`nil` means auto-indent the current line after a semicolon or space. Default is `nil`.

`octave-auto-newline`

Non-`nil` means auto-insert a newline and indent after semicolons are typed. The default value is `nil`.

`octave-blink-matching-block`

Non-`nil` means show matching begin of block when inserting a space, newline or ‘;’ after an `else` or `end` keyword. Default is `t`. This is an extremely useful feature for automatically verifying that the keywords match—if they don’t, an error message is displayed.

`octave-block-offset`

Extra indentation applied to statements in block structures. Default is 2.

`octave-continuation-offset`

Extra indentation applied to Octave continuation lines. Default is 4.

`octave-continuation-string`

String used for Octave continuation lines. Normally ‘\’.

`octave-mode-startup-message`

If `t` (default), a startup message is displayed when Octave mode is called.

If Font Lock mode is enabled, Octave mode will display

- strings in `font-lock-string-face`
- comments in `font-lock-comment-face`
- the Octave reserved words (such as all block keywords) and the text functions (such as ‘`cd`’ or ‘`who`’) which are also reserved using `font-lock-keyword-face`

- the builtin operators (`'&&'`, `'<>'`, ...) using `font-lock-reference-face`
- the builtin variables (such as `'warn_fortran_indexing'`, `'NaN'` or `'LOADPATH'`) in `font-lock-variable-name-face`
- and the function names in function declarations in `font-lock-function-name-face`.

There is also rudimentary support for Imenu (currently, function names can be indexed).

You can generate TAGS files for Emacs from Octave `.m` files using the shell script `otags` that is installed alongside your copy of Octave.

Customization of Octave mode can be performed by modification of the variable `octave-mode-hook`. If the value of this variable is non-`nil`, turning on Octave mode calls its value.

If you discover a problem with Octave mode, you can conveniently send a bug report using `C-c C-b` (`octave-submit-bug-report`). This automatically sets up a mail buffer with version information already added. You just need to add a description of the problem, including a reproducible test case and send the message.

D.3 Running Octave From Within Emacs

The package `'octave'` provides commands for running an inferior Octave process in a special Emacs buffer. Use

`M-x run-octave`

to directly start an inferior Octave process. If Emacs does not know about this command, add the line

```
(autoload 'run-octave "octave-inf" nil t)
```

to your `.emacs` file.

This will start Octave in a special buffer the name of which is specified by the variable `inferior-octave-buffer` and defaults to `"*Inferior Octave*"`. From within this buffer, you can interact with the inferior Octave process 'as usual', i.e., by entering Octave commands at the prompt. The buffer is in Inferior Octave mode, which is derived from the standard Comint mode, a major mode for interacting with an inferior interpreter. See the documentation for `comint-mode` for more details, and use `C-h b` to find out about available special keybindings.

You can also communicate with an inferior Octave process from within files with Octave code (i.e., buffers in Octave mode), using the following commands.

- `C-c i l` Send the current line to the inferior Octave process (`octave-send-line`). With positive prefix argument *N*, send that many lines. If `octave-send-line-auto-forward` is non-`nil`, go to the next unsent code line.
- `C-c i b` Send the current block to the inferior Octave process (`octave-send-block`).
- `C-c i f` Send the current function to the inferior Octave process (`octave-send-defun`).
- `C-c i r` Send the region to the inferior Octave process (`octave-send-region`).
- `C-c i s` Make sure that `'inferior-octave-buffer'` is displayed (`octave-show-process-buffer`).
- `C-c i h` Delete all windows that display the inferior Octave buffer (`octave-hide-process-buffer`).

`C-c i k` Kill the inferior Octave process and its buffer (`octave-kill-process`).

The effect of the commands which send code to the Octave process can be customized by the following variables.

`octave-send-echo-input`

Non-`nil` means echo input sent to the inferior Octave process. Default is `t`.

`octave-send-show-buffer`

Non-`nil` means display the buffer running the Octave process after sending a command (but without selecting it). Default is `t`.

If you send code and there is no inferior Octave process yet, it will be started automatically.

The startup of the inferior Octave process is highly customizable. The variable `inferior-octave-startup-args` can be used for specifying command line arguments to be passed to Octave on startup as a list of strings. For example, to suppress the startup message and use ‘traditional’ mode, set this to `'("-q" "--traditional")`. You can also specify a startup file of Octave commands to be loaded on startup; note that these commands will not produce any visible output in the process buffer. Which file to use is controlled by the variable `inferior-octave-startup-file`. If this is `nil`, the file `~/ .emacs-octave` is used if it exists.

And finally, `inferior-octave-mode-hook` is run after starting the process and putting its buffer into Inferior Octave mode. Hence, if you like the up and down arrow keys to behave in the interaction buffer as in the shell, and you want this buffer to use nice colors, add

```
(add-hook 'inferior-octave-mode-hook
  (lambda ()
    (turn-on-font-lock)
    (define-key inferior-octave-mode-map [up]
      'comint-previous-input)
    (define-key inferior-octave-mode-map [down]
      'comint-next-input)))
```

to your `.emacs` file. You could also swap the roles of `C-a` (`beginning-of-line`) and `C-c C-a` (`comint-bol`) using this hook.

Note: If you set your Octave prompts to something different from the defaults, make sure that `inferior-octave-prompt` matches them. Otherwise, *nothing* will work, because Emacs will have no idea when Octave is waiting for input, or done sending output.

D.4 Using the Emacs Info Reader for Octave

You can also set up the Emacs Info reader for dealing with the results of Octave’s `help -i`. For this, the package `gnuserv` needs to be installed, which unfortunately still does not come with GNU Emacs (it does with XEmacs). It can be retrieved from any GNU Emacs Lisp Code Directory archive, e.g. <ftp://ftp.cis.ohio-state.edu/pub/gnu/emacs/elisp-archive>, in the ‘packages’ subdirectory. A recent version of `gnuserv` is available from <http://www.meltin.net/hacks/emacs/src/gnuserv-3.12.2.tar.gz>.

If `'gnuserv'` is installed, add the lines

```
(autoload 'octave-help "octave-hlp" nil t)
(require 'gnuserv)
(gnuserv-start)
```

to your `'emacs'` file.

You can use either 'plain' Emacs Info or the function `octave-help` as your Octave info reader (for `'help -i'`). In the former case, set the Octave variable `INFO_PROGRAM` to `"info-emacs-info"`. The latter is perhaps more attractive because it allows to look up keys in the indices of *several* info files related to Octave (provided that the Emacs variable `octave-help-files` is set correctly). In this case, set `INFO_PROGRAM` to `"info-emacs-octave-help"`.

If you use Octave from within Emacs, these settings are best done in the `'~/.emacs-octave'` startup file (or the file pointed to by the Emacs variable `inferior-octave-startup-file`).

Appendix E Grammar

Someday I hope to expand this to include a semi-formal description of Octave's language.

E.1 Keywords

The following identifiers are keywords, and may not be used as variable or function names:

<code>all_va_args</code>	<code>endwhile</code>
<code>break</code>	<code>for</code>
<code>case</code>	<code>function</code>
<code>catch</code>	<code>global</code>
<code>continue</code>	<code>gplot</code>
<code>else</code>	<code>gsplot</code>
<code>elseif</code>	<code>if</code>
<code>end</code>	<code>otherwise</code>
<code>end_try_catch</code>	<code>return</code>
<code>end_unwind_protect</code>	<code>switch</code>
<code>endfor</code>	<code>try</code>
<code>endfunction</code>	<code>unwind_protect</code>
<code>endif</code>	<code>unwind_protect_cleanup</code>
<code>endswitch</code>	<code>while</code>

The following command-like functions are also special. They may be used as simple variable names, but not as formal parameters for functions, or as the names of structure variables. Failed assignments leave them undefined (you can recover the original definition as a function using `clear`).

<code>casesen</code>	<code>echo</code>	<code>load</code>	<code>show</code>
<code>cd</code>	<code>edit_history</code>	<code>ls</code>	<code>type</code>
<code>chdir</code>	<code>format</code>	<code>more</code>	<code>which</code>
<code>clear</code>	<code>help</code>	<code>run_history</code>	<code>who</code>
<code>diary</code>	<code>history</code>	<code>save</code>	<code>whos</code>
<code>dir</code>	<code>hold</code>	<code>set</code>	

Appendix F GNU GENERAL PUBLIC LICENSE

Version 2, June 1991

Copyright © 1989, 1991 Free Software Foundation, Inc.
59 Temple Place - Suite 330, Boston, MA 02111-1307, USA

Everyone is permitted to copy and distribute verbatim copies of this license document, but changing it is not allowed.

F.1 Preamble

The licenses for most software are designed to take away your freedom to share and change it. By contrast, the GNU General Public License is intended to guarantee your freedom to share and change free software—to make sure the software is free for all its users. This General Public License applies to most of the Free Software Foundation's software and to any other program whose authors commit to using it. (Some other Free Software Foundation software is covered by the GNU Library General Public License instead.) You can apply it to your programs, too.

When we speak of free software, we are referring to freedom, not price. Our General Public Licenses are designed to make sure that you have the freedom to distribute copies of free software (and charge for this service if you wish), that you receive source code or can get it if you want it, that you can change the software or use pieces of it in new free programs; and that you know you can do these things.

To protect your rights, we need to make restrictions that forbid anyone to deny you these rights or to ask you to surrender the rights. These restrictions translate to certain responsibilities for you if you distribute copies of the software, or if you modify it.

For example, if you distribute copies of such a program, whether gratis or for a fee, you must give the recipients all the rights that you have. You must make sure that they, too, receive or can get the source code. And you must show them these terms so they know their rights.

We protect your rights with two steps: (1) copyright the software, and (2) offer you this license which gives you legal permission to copy, distribute and/or modify the software.

Also, for each author's protection and ours, we want to make certain that everyone understands that there is no warranty for this free software. If the software is modified by someone else and passed on, we want its recipients to know that what they have is not the original, so that any problems introduced by others will not reflect on the original authors' reputations.

Finally, any free program is threatened constantly by software patents. We wish to avoid the danger that redistributors of a free program will individually obtain patent licenses, in effect making the program proprietary. To prevent this, we have made it clear that any patent must be licensed for everyone's free use or not licensed at all.

The precise terms and conditions for copying, distribution and modification follow.

F.2 TERMS AND CONDITIONS FOR COPYING, DISTRIBUTION AND MODIFICATION

0. This License applies to any program or other work which contains a notice placed by the copyright holder saying it may be distributed under the terms of this General Public License. The “Program”, below, refers to any such program or work, and a “work based on the Program” means either the Program or any derivative work under copyright law: that is to say, a work containing the Program or a portion of it, either verbatim or with modifications and/or translated into another language. (Hereinafter, translation is included without limitation in the term “modification”.) Each licensee is addressed as “you”.

Activities other than copying, distribution and modification are not covered by this License; they are outside its scope. The act of running the Program is not restricted, and the output from the Program is covered only if its contents constitute a work based on the Program (independent of having been made by running the Program). Whether that is true depends on what the Program does.

1. You may copy and distribute verbatim copies of the Program’s source code as you receive it, in any medium, provided that you conspicuously and appropriately publish on each copy an appropriate copyright notice and disclaimer of warranty; keep intact all the notices that refer to this License and to the absence of any warranty; and give any other recipients of the Program a copy of this License along with the Program.

You may charge a fee for the physical act of transferring a copy, and you may at your option offer warranty protection in exchange for a fee.

2. You may modify your copy or copies of the Program or any portion of it, thus forming a work based on the Program, and copy and distribute such modifications or work under the terms of Section 1 above, provided that you also meet all of these conditions:
 - a. You must cause the modified files to carry prominent notices stating that you changed the files and the date of any change.
 - b. You must cause any work that you distribute or publish, that in whole or in part contains or is derived from the Program or any part thereof, to be licensed as a whole at no charge to all third parties under the terms of this License.
 - c. If the modified program normally reads commands interactively when run, you must cause it, when started running for such interactive use in the most ordinary way, to print or display an announcement including an appropriate copyright notice and a notice that there is no warranty (or else, saying that you provide a warranty) and that users may redistribute the program under these conditions, and telling the user how to view a copy of this License. (Exception: if the Program itself is interactive but does not normally print such an announcement, your work based on the Program is not required to print an announcement.)

These requirements apply to the modified work as a whole. If identifiable sections of that work are not derived from the Program, and can be reasonably considered independent and separate works in themselves, then this License, and its terms, do not apply to those sections when you distribute them as separate works. But when you distribute the same sections as part of a whole which is a work based on the Program, the distribution of the whole must be on the terms of this License, whose permissions

for other licensees extend to the entire whole, and thus to each and every part regardless of who wrote it.

Thus, it is not the intent of this section to claim rights or contest your rights to work written entirely by you; rather, the intent is to exercise the right to control the distribution of derivative or collective works based on the Program.

In addition, mere aggregation of another work not based on the Program with the Program (or with a work based on the Program) on a volume of a storage or distribution medium does not bring the other work under the scope of this License.

3. You may copy and distribute the Program (or a work based on it, under Section 2) in object code or executable form under the terms of Sections 1 and 2 above provided that you also do one of the following:
 - a. Accompany it with the complete corresponding machine-readable source code, which must be distributed under the terms of Sections 1 and 2 above on a medium customarily used for software interchange; or,
 - b. Accompany it with a written offer, valid for at least three years, to give any third party, for a charge no more than your cost of physically performing source distribution, a complete machine-readable copy of the corresponding source code, to be distributed under the terms of Sections 1 and 2 above on a medium customarily used for software interchange; or,
 - c. Accompany it with the information you received as to the offer to distribute corresponding source code. (This alternative is allowed only for noncommercial distribution and only if you received the program in object code or executable form with such an offer, in accord with Subsection b above.)

The source code for a work means the preferred form of the work for making modifications to it. For an executable work, complete source code means all the source code for all modules it contains, plus any associated interface definition files, plus the scripts used to control compilation and installation of the executable. However, as a special exception, the source code distributed need not include anything that is normally distributed (in either source or binary form) with the major components (compiler, kernel, and so on) of the operating system on which the executable runs, unless that component itself accompanies the executable.

If distribution of executable or object code is made by offering access to copy from a designated place, then offering equivalent access to copy the source code from the same place counts as distribution of the source code, even though third parties are not compelled to copy the source along with the object code.

4. You may not copy, modify, sublicense, or distribute the Program except as expressly provided under this License. Any attempt otherwise to copy, modify, sublicense or distribute the Program is void, and will automatically terminate your rights under this License. However, parties who have received copies, or rights, from you under this License will not have their licenses terminated so long as such parties remain in full compliance.
5. You are not required to accept this License, since you have not signed it. However, nothing else grants you permission to modify or distribute the Program or its derivative works. These actions are prohibited by law if you do not accept this License. Therefore, by modifying or distributing the Program (or any work based on the Program), you

indicate your acceptance of this License to do so, and all its terms and conditions for copying, distributing or modifying the Program or works based on it.

6. Each time you redistribute the Program (or any work based on the Program), the recipient automatically receives a license from the original licensor to copy, distribute or modify the Program subject to these terms and conditions. You may not impose any further restrictions on the recipients' exercise of the rights granted herein. You are not responsible for enforcing compliance by third parties to this License.
7. If, as a consequence of a court judgment or allegation of patent infringement or for any other reason (not limited to patent issues), conditions are imposed on you (whether by court order, agreement or otherwise) that contradict the conditions of this License, they do not excuse you from the conditions of this License. If you cannot distribute so as to satisfy simultaneously your obligations under this License and any other pertinent obligations, then as a consequence you may not distribute the Program at all. For example, if a patent license would not permit royalty-free redistribution of the Program by all those who receive copies directly or indirectly through you, then the only way you could satisfy both it and this License would be to refrain entirely from distribution of the Program.

If any portion of this section is held invalid or unenforceable under any particular circumstance, the balance of the section is intended to apply and the section as a whole is intended to apply in other circumstances.

It is not the purpose of this section to induce you to infringe any patents or other property right claims or to contest validity of any such claims; this section has the sole purpose of protecting the integrity of the free software distribution system, which is implemented by public license practices. Many people have made generous contributions to the wide range of software distributed through that system in reliance on consistent application of that system; it is up to the author/donor to decide if he or she is willing to distribute software through any other system and a licensee cannot impose that choice.

This section is intended to make thoroughly clear what is believed to be a consequence of the rest of this License.

8. If the distribution and/or use of the Program is restricted in certain countries either by patents or by copyrighted interfaces, the original copyright holder who places the Program under this License may add an explicit geographical distribution limitation excluding those countries, so that distribution is permitted only in or among countries not thus excluded. In such case, this License incorporates the limitation as if written in the body of this License.
9. The Free Software Foundation may publish revised and/or new versions of the General Public License from time to time. Such new versions will be similar in spirit to the present version, but may differ in detail to address new problems or concerns.

Each version is given a distinguishing version number. If the Program specifies a version number of this License which applies to it and “any later version”, you have the option of following the terms and conditions either of that version or of any later version published by the Free Software Foundation. If the Program does not specify a version number of this License, you may choose any version ever published by the Free Software Foundation.

10. If you wish to incorporate parts of the Program into other free programs whose distribution conditions are different, write to the author to ask for permission. For software which is copyrighted by the Free Software Foundation, write to the Free Software Foundation; we sometimes make exceptions for this. Our decision will be guided by the two goals of preserving the free status of all derivatives of our free software and of promoting the sharing and reuse of software generally.

NO WARRANTY

11. BECAUSE THE PROGRAM IS LICENSED FREE OF CHARGE, THERE IS NO WARRANTY FOR THE PROGRAM, TO THE EXTENT PERMITTED BY APPLICABLE LAW. EXCEPT WHEN OTHERWISE STATED IN WRITING THE COPYRIGHT HOLDERS AND/OR OTHER PARTIES PROVIDE THE PROGRAM "AS IS" WITHOUT WARRANTY OF ANY KIND, EITHER EXPRESSED OR IMPLIED, INCLUDING, BUT NOT LIMITED TO, THE IMPLIED WARRANTIES OF MERCHANTABILITY AND FITNESS FOR A PARTICULAR PURPOSE. THE ENTIRE RISK AS TO THE QUALITY AND PERFORMANCE OF THE PROGRAM IS WITH YOU. SHOULD THE PROGRAM PROVE DEFECTIVE, YOU ASSUME THE COST OF ALL NECESSARY SERVICING, REPAIR OR CORRECTION.
12. IN NO EVENT UNLESS REQUIRED BY APPLICABLE LAW OR AGREED TO IN WRITING WILL ANY COPYRIGHT HOLDER, OR ANY OTHER PARTY WHO MAY MODIFY AND/OR REDISTRIBUTE THE PROGRAM AS PERMITTED ABOVE, BE LIABLE TO YOU FOR DAMAGES, INCLUDING ANY GENERAL, SPECIAL, INCIDENTAL OR CONSEQUENTIAL DAMAGES ARISING OUT OF THE USE OR INABILITY TO USE THE PROGRAM (INCLUDING BUT NOT LIMITED TO LOSS OF DATA OR DATA BEING RENDERED INACCURATE OR LOSSES SUSTAINED BY YOU OR THIRD PARTIES OR A FAILURE OF THE PROGRAM TO OPERATE WITH ANY OTHER PROGRAMS), EVEN IF SUCH HOLDER OR OTHER PARTY HAS BEEN ADVISED OF THE POSSIBILITY OF SUCH DAMAGES.

END OF TERMS AND CONDITIONS

F.3 Appendix: How to Apply These Terms to Your New Programs

If you develop a new program, and you want it to be of the greatest possible use to the public, the best way to achieve this is to make it free software which everyone can redistribute and change under these terms.

To do so, attach the following notices to the program. It is safest to attach them to the start of each source file to most effectively convey the exclusion of warranty; and each file should have at least the “copyright” line and a pointer to where the full notice is found.

one line to give the program’s name and a brief idea of what it does.

Copyright (C) 19yy *name of author*

This program is free software; you can redistribute it and/or modify it under the terms of the GNU General Public License as published by the Free Software Foundation; either version 2 of the License, or (at your option) any later version.

This program is distributed in the hope that it will be useful, but WITHOUT ANY WARRANTY; without even the implied warranty of MERCHANTABILITY or FITNESS FOR A PARTICULAR PURPOSE. See the GNU General Public License for more details.

You should have received a copy of the GNU General Public License along with this program; if not, write to the Free Software Foundation, Inc., 59 Temple Place - Suite 330, Boston, MA 02111-1307, USA.

Also add information on how to contact you by electronic and paper mail.

If the program is interactive, make it output a short notice like this when it starts in an interactive mode:

```
Gnomovision version 69, Copyright (C) 19yy name of author
Gnomovision comes with ABSOLUTELY NO WARRANTY; for details
type ‘show w’. This is free software, and you are welcome
to redistribute it under certain conditions; type ‘show c’
for details.
```

The hypothetical commands ‘show w’ and ‘show c’ should show the appropriate parts of the General Public License. Of course, the commands you use may be called something other than ‘show w’ and ‘show c’; they could even be mouse-clicks or menu items—whatever suits your program.

You should also get your employer (if you work as a programmer) or your school, if any, to sign a “copyright disclaimer” for the program, if necessary. Here is a sample; alter the names:

```
Yoyodyne, Inc., hereby disclaims all copyright interest in the program
‘Gnomovision’ (which makes passes at compilers) written by James Hacker.
```

```
signature of Ty Coon, 1 April 1989
Ty Coon, President of Vice
```

This General Public License does not permit incorporating your program into proprietary programs. If your program is a subroutine library, you may consider it more useful to permit

linking proprietary applications with the library. If this is what you want to do, use the GNU Library General Public License instead of this License.

Concept Index

#	
'#'	26
'#!'	25
%	
'%'	26
-	
--braindead	14
--debug	13
--echo-commands	13
--exec-path <i>path</i>	13
--help	13
--info-file <i>filename</i>	13
--info-program <i>program</i>	13
--interactive	14
--no-init-file	14
--no-line-editing	14
--no-site-file	14
--norc	14
--path <i>path</i>	14
--quiet	14
--silent	14
--traditional	14
--verbose	14
--version	14
-?	13
-d	13
-f	14
-h	13
-i	14
-p <i>path</i>	14
-q	14
-v	14
-V	14
-x	13
.	
...	95
... continuation marker	88
.octaverc	16
~	
~/octaverc	16
\	
\ continuation marker	88

A	
acknowledgements	1
addition	68
and operator	70
answers, incorrect	324, 326
any key	8
arguments in function call	66
arithmetic operators	68
assignment expressions	72
assignment operators	72
B	
body of a loop	82
boolean expressions	70
boolean operators	70
break statement	85
bug criteria	324
bug report mailing lists	325
bugs	324
bugs, investigating	326
bugs, known	323
bugs, reporting	325
built-in data types	29
built-in function	10
C	
case statement	81
catch	88
cell arrays	51
character strings	30, 39
Cholesky factorization	176
clearing the screen	18
coding standards	317
command and output logs	23
command completion	20
command descriptions	10
command echoing	23
command history	20
command options	13
command-line editing	18
comments	26
comparison expressions	70
complex-conjugate transpose	68
compounding, value of	225
containers	51
continuation lines	88
continue statement	86
contributing to Octave	4
contributors	1

conversion specifications (<code>printf</code>)	120
conversion specifications (<code>scanf</code>)	125
copyright	343
core dump	324
customizing the prompt	22

D

DAE	187
data structures	30, 47
data types	29
data types, built-in	29
data types, user-defined	30
decrement operator	74
defining functions	91
description format	9
diary of commands and output	23
Differential Equations	187
diffs, submitting	327
distribution of Octave	4
division	68
<code>do-until</code> statement	83
documentation notation	8
documenting Octave programs	26
dynamic linking	100

E

echoing executing commands	23
editing the command line	18
element-by-element evaluation	71
<code>else</code> statement	79
<code>elseif</code> statement	79
Emacs TAGS files	339
<code>end</code> statement	79
<code>end_try_catch</code>	88
<code>end_unwind_protect</code>	87
<code>endfor</code> statement	84
<code>endfunction</code> statement	91
<code>endif</code> statement	79
<code>endswitch</code> statement	81
<code>endwhile</code> statement	82
equality operator	70
equality, tests for	70
equations, nonlinear	183
erroneous messages	324
erroneous results	324, 326
error message notation	9
error messages	24
error messages, incorrect	324
escape sequence notation	39
evaluation notation	8

executable scripts	25
execution speed	317
exiting octave	5, 16
exponentiation	68
expression, range	37
expressions	65
expressions, assignment	72
expressions, boolean	70
expressions, comparison	70
expressions, logical	70

F

factorial function	68
fatal signal	324
financial functions	225
flag character (<code>printf</code>)	121
flag character (<code>scanf</code>)	126
flying high and fast	55
fonts	8
<code>for</code> statement	84
Fordyce, A. P.	78
Frobenius norm	174
function descriptions	9
function file	10, 96
<code>function</code> statement	91
functions, user-defined	91
funding Octave development	4

G

getting a good job	55
<code>global</code> statement	55
global variables	55
grammar rules	343
graphics	135
greater than operator	70

H

handle, function handles	103
header comments	319
help, on-line	16
help, where to find	327
Hermitian operator	68
Hessenberg decomposition	176
history	1
history of commands	20

I

if statement 79
 improving Octave 324, 327
 incorrect error messages 324
 incorrect output 324, 326
 incorrect results 324, 326
 increment operator 74
 infinity norm 174
 initialization 15
 inline, inline functions 103
 input conversions, for **scanf** 126
 input history 20
 installation trouble 323
 installing Octave 329
 introduction 5
 invalid input 324

J

job hunting 55

K

keywords 343
 known causes of trouble 323

L

language definition 343
 less than operator 70
 lists 51
 loadable function 10
 logging commands and output 23
 logical expressions 70
 logical operators 70
 loop 82
 looping over structure elements 84
 LP 199
 LU decomposition 176
 lvalue 73

M

mapping function 10
 matching failure, in **scanf** 125
 matrices 33
 matrix multiplication 68
 maximum field width (**scanf**) 126
 messages, error 24
 minimum field width (**printf**) 121
 missing data 29

money 225
 multiplication 68

N

negation 68
 NLP 199
 nonlinear equations 183
 nonlinear programming 199
 not operator 70
 numeric constant 29, 33
 numeric value 29, 33

O

Octave command options 13
 ODE 187
 on-line help 16
 operator precedence 75
 operators, arithmetic 68
 operators, assignment 72
 operators, boolean 70
 operators, decrement 74
 operators, increment 74
 operators, logical 70
 operators, relational 70
 optimization 199
 options, Octave command 13
 or operator 70
 oregonator 188
otags 339
otherwise statement 81
 output conversions, for **printf** 122

P

partial fraction expansion 231
 patches, submitting 327
persistent statement 56
 persistent variables 56
 plotting 135
 precision (**printf**) 122
 printing notation 9
 program, self contained 25
 programs 26
 prompt customization 22

Q

QP	199
QR factorization	176
quadratic programming	199
quitting octave	5, 16
quotient	68

R

range expressions	37
relational operators	70
reporting bugs	324, 325
results, incorrect	324, 326

S

Schur decomposition	178
script files	91
scripts	25
self contained programs	25
short-circuit evaluation	71
side effect	73
singular value decomposition	179
speedups	317
standards of coding style	317
startup	15
startup files	15
statements	79
strings	30, 39
structure elements, looping over	84
structures	30, 47
submitting diffs	327
submitting patches	327
subtraction	68
suggestions	324
switch statement	81

T

TAGS	339
tests for equality	70
tips	317
transpose	68
transpose, complex-conjugate	68
troubleshooting	323
try statement	88

U

unary minus	68
undefined behavior	324
undefined function value	324
unwind_protect statement	87
unwind_protect_cleanup	87
use of comments	26
user-defined data types	30
user-defined functions	91
user-defined variables	55
Utility Functions	162, 163

V

variable descriptions	11
variable-length argument lists	95
variable-length return lists	95
variables, global	55
variables, persistent	56
variables, user-defined	55

W

warranty	343
while statement	82
wrong answers	324, 326

Variable Index

A

ans 110
 argv 15
 automatic_replot 60, 134

B

beep_on_error 60, 105

C

completion_append_char 20, 60
 crash_dumps_octave_core 61, 115

D

debug_on_error 107
 debug_on_interrupt 107
 debug_on_warning 107
 DEFAULT_LOADPATH 60, 97
 default_save_format 61, 116
 do_what_i_mean_not_what_i_say 11

E

e 171
 echo_executing_commands 24
 EDITOR 22, 60, 64
 eps 171
 EXEC_PATH 60, 309

F

F_DUPFD 311
 F_GETFD 311
 F_GETFL 311
 F_SETFD 311
 F_SETFL 311
 false 37
 fixed_point_format 36, 61

G

gnuplot_binary 61, 145
 gnuplot_command_axes 145
 gnuplot_command_end 145
 gnuplot_command_plot 145
 gnuplot_command_replot 145
 gnuplot_command_splot 145
 gnuplot_command_title 145
 gnuplot_command_using 145

gnuplot_command_with 145
 gnuplot_has_frames 145

H

history_file 22, 61
 history_size 22, 61

I

i 171
 I 171
 ignore_function_time_stamp 61, 98
 IMAGEPATH 293
 inf 171
 Inf 171
 INFO_FILE 17, 60
 INFO_PROGRAM 17, 60

J

j 171
 J 171

L

LOADPATH 60, 97

M

MAKEINFO_PROGRAM 17
 max_recursion_depth 61, 68

N

NA 29
 nan 171
 NaN 171

O

O_APPEND	311
O_ASYNC	311
O_NONBLOCK	311
O_RDONLY	311
O_RDWR	311
O_SYNC	311
O_WRONLY	311
OCTAVE_EXEC_PATH	64
OCTAVE_HISTFILE	64
OCTAVE_HISTSIZE	64
OCTAVE_HOME	60
OCTAVE_INFO_FILE	64
OCTAVE_INFO_PROGRAM	64
OCTAVE_PATH	64
OCTAVE_VERSION	315
output_max_field_width	35, 61
output_precision	35, 61

P

page_output_immediately	109
page_screen_output	61, 109
PAGER	60, 109
pi	171
print_answer_id_name	61, 113
print_empty_dimensions	36, 62
print_rhs_assign_val	74
program_invocation_name	15
program_name	15
PS1	23, 60
PS2	23, 60
PS4	23, 60

R

realmax	172
realmin	172
return	96
return_last_computed_value	62

S

save_header_format_string	116
save_precision	62, 116
saving_history	22, 62

SEEK_CUR	132
SEEK_END	132
SEEK_SET	132
sighup_dumps_octave_core	62, 115
sigterm_dumps_octave_core	62, 116
silent_functions	62, 93
split_long_rows	35, 62
stderr	117
stdin	117
stdout	117
string_fill_char	41
struct_levels_to_print	48, 62
suppress_verbose_help_message	17, 62

T

true	37
------	----

V

variables_can_hide_functions	102
------------------------------	-----

W

warn_assign_as_truth_value	62, 81
warn_comma_in_global_decl	62
warn_divide_by_zero	63, 70
warn_empty_list_elements	37, 63
warn_fortran_indexing	63, 65
warn_function_name_clash	63, 98
warn_future_time_stamp	98
warn_imag_to_real	63, 158
warn_missing_semicolon	63, 93
warn_neg_dim_as_zero	63, 158
warn_num_to_str	45, 63
warn_reload_forces_clear	63, 102
warn_resize_on_range_error	63, 66
warn_separator_insert	35, 63
warn_single_quote_string	45, 63
warn_str_to_num	45, 64
warn_undefined_return_values	64, 95
warn_variable_switch_label	64, 82
whos_line_format	58

Function Index

(

(*w_type*..... 296
(*w*, 285

=

= 152, 288, 290

[

[*theta*, 170
[*x*, 170, 171

A

abccdim..... 259
abs..... 164
acos..... 165
acosh..... 166
acot..... 165
acoth..... 166
acsc..... 165
acsch..... 166
airy..... 168
all..... 147
analdemo..... 259
angle..... 164
anova..... 206
any..... 147
append..... 51
arch_fit..... 286
arch_rnd..... 286
arch_test..... 286
are..... 255
arg..... 164
argnames..... 103
arma_rnd..... 287
asctime..... 300
asec..... 165
asech..... 166
asin..... 165
asinh..... 166
atan..... 165
atan2..... 166
atanh..... 166
atexit..... 16
autocor..... 287
autocov..... 287
autoreg_matrix..... 287
axis..... 137
axis2dlim..... 278

B

balance..... 173
bar..... 138
bartlett..... 287
bartlett_test..... 207
base2dec..... 44
bddemo..... 246
besselh..... 167
besseli..... 167
besselj..... 167
besselk..... 167
bessely..... 167
beta..... 168
beta_cdf..... 214
beta_inv..... 214
beta_pdf..... 214
beta_rnd..... 214
betainc..... 169
bincoeff..... 169
binomial_cdf..... 214
binomial_inv..... 214
binomial_pdf..... 214
binomial_rnd..... 215
blackman..... 287
blanks..... 40
bode..... 267
bode_bounds..... 268
bottom_title..... 143, 144
bug_report..... 324, 325
buildssic..... 246

C

c2d..... 264
cat..... 150
cauchy_cdf..... 215
cauchy_inv..... 215
cauchy_pdf..... 215
cauchy_rnd..... 215
cd..... 10, 312
ceil..... 161
cell..... 51
cellstr..... 52
center..... 206
char..... 40
chdir..... 10, 312
chisquare_cdf..... 215
chisquare_inv..... 215
chisquare_pdf..... 215
chisquare_rnd..... 216
chisquare_test_homogeneity..... 207
chisquare_test_independence..... 207

chol.....	176	dbstatus	107
clc.....	19	dbstop.....	107
clear.....	57	dbtype.....	107
clearplot.....	137	dbwhere.....	107
clg.....	137	dcgain.....	266
clock.....	302	deblank.....	41
cloglog.....	206	dec2base.....	43
closeplot.....	137	dec2bin.....	43
colloc.....	186	dec2hex.....	43
colormap.....	291	deconv.....	229
columns.....	30	DEMOcontrol.....	233
com2str.....	40	det.....	173
common_size.....	149	detrend.....	283
commutation_matrix.....	170	dgkfdemo.....	270
compan.....	229	dgram.....	256
complement.....	227	diag.....	157
completion_matches.....	20	diary.....	23
computer.....	314	diff.....	148
cond.....	173	discrete_cdf.....	216
conj.....	164	discrete_inv.....	216
contour.....	139	discrete_pdf.....	216
conv.....	229	discrete_rnd.....	216
cor.....	206	disp.....	110
cor_test.....	207	dkalman.....	273
corrcoef.....	202	dlqe.....	272
cos.....	165	dlqr.....	273
cosh.....	166	dlyap.....	257
cot.....	165	dmr2d.....	265
coth.....	166	dmult.....	173
cov.....	202	do_string_escapes.....	45
cputime.....	303	document.....	59
create_set.....	227	dot.....	174
cross.....	170	dre.....	256
csc.....	165	dup2.....	310
csch.....	166	duplication_matrix.....	170
ctime.....	299	durbinlevinson.....	288
ctrb.....	259		
cumprod.....	167	E	
cumsum.....	167	echo.....	24
cut.....	206	edit_history.....	21
		eig.....	174
D		empirical_cdf.....	216
d2c.....	265	empirical_inv.....	216
damp.....	266	empirical_pdf.....	216
dare.....	255	empirical_rnd.....	216
daspk.....	192	endgrent.....	314
daspk_options.....	193	endpwent.....	313
dasrt.....	195	erf.....	169
dasrt_options.....	196	erfc.....	169
date.....	302	erfinv.....	169
dbclear.....	107	error.....	105

errorbar 140
etime 303
eval 77
exec 310
exist 59
exit 16
exp 161
expm 180
exponential_cdf 217
exponential_inv 217
exponential_pdf 217
exponential_rnd 217
eye 155

F

f_cdf 217
f_inv 217
f_pdf 217
f_rnd 217
f_test_regression 208
fclose 119
fcntl 311
fdisp 110
feof 131
ferror 131
feval 77
fflush 110
fft 283
fft2 283, 284
fftconv 284
fftfilt 284
fftn 284
fftshift 288
fgetl 119
fgets 119
fieldnames 49
figure 144
file_in_loadpath 97
file_in_path 307
filter 284
find 148
findstr 41
finite 148
fir2sys 235
fix 161
flipdim 149
fliplr 149
flipud 149
floor 161
fnmatch 307
foo 9

fopen 118
fork 309
format 111
formula 103
fprintf 120
fputs 119
fractdiff 288
frdemo 267
fread 128
freport 131
freqchkw 268
freqz 285
frewind 132
fscanf 125
fseek 132
fsolve 183
fsolve_options 183
ftell 132
func2str 103
functions 103
fv 225
fvl 225
fwrite 130

G

gamma 169
gamma_cdf 217
gamma_inv 218
gamma_pdf 218
gamma_rnd 218
gammainc 169
gammaln 170
gcd 161
geometric_cdf 218
geometric_inv 218
geometric_pdf 218
geometric_rnd 218
getegid 312
getenv 312
geteuid 311
getgid 312
getgrent 314
getgrgid 314
getgrnam 314
getpgrp 311
getpid 311
getppid 311
getpwent 313
getpwnam 313
getpwuid 313
getrusage 315

getuid.....	312	image.....	291
givens.....	174	imagesc.....	291
glob.....	306	impulse.....	266
gls.....	199	imshow.....	292
gmtime.....	300	ind2gray.....	292
gplot.....	133	ind2rgb.....	292
gram.....	257	index.....	41
graw.....	145	inline.....	103
gray.....	291	input.....	113
gray2ind.....	291	int2str.....	40
grid.....	142	intersection.....	227
gset.....	134	inv.....	174
gshow.....	134	inverse.....	174
gsplot.....	141	invhilb.....	159
H			
h2norm.....	259	ipermute.....	151
h2syn.....	273	iqr.....	205
hamming.....	288	irr.....	225
hankel.....	158	is_abcd.....	261
hanning.....	288	is_controllable.....	261
help.....	17	is_detectable.....	261
hess.....	176	is_dgkf.....	261
hex2dec.....	43	is_digital.....	262
hilb.....	158	is_duplicate_entry.....	147
hinf_ctr.....	274	is_leap_year.....	303
hinfdemo.....	270	is_nan_or_na.....	30
hinfnorm.....	259	is_observable.....	263
hinfosyn.....	274	is_sample.....	263
hinfosyn_chk.....	275	is_signal_list.....	263
hinfosyn_ric.....	276	is_siso.....	263
hist.....	139	is_stabilizable.....	263
history.....	21	is_stable.....	263
hold.....	136	isalnum.....	46
home.....	19	isalpha.....	46
horzcat.....	151	isascii.....	46
hotelling_test.....	208	isbool.....	38
hotelling_test_2.....	208	iscell.....	52
housh.....	180	ischar.....	41
hsv_map.....	293	iscntrl.....	46
hurst.....	289	iscomplex.....	38
hypergeometric_cdf.....	218	isdigit.....	46
hypergeometric_inv.....	219	isempty.....	31
hypergeometric_pdf.....	219	isfield.....	49
hypergeometric_rnd.....	219	isglobal.....	56
I			
ifft.....	283	isgraph.....	46
ifftn.....	284	ishold.....	136
imag.....	164	isieee.....	315
		isinf.....	148
		isletter.....	46
		islist.....	51
		islower.....	46
		ismatrix.....	38
		isna.....	29

isnan..... 148
 isnumeric..... 38
 isprint..... 46
 ispunct..... 46
 isreal..... 38
 isscalar..... 38
 isspace..... 46
 issquare..... 38
 isstr..... 41
 isstream..... 53
 isstruct..... 49
 issymmetric..... 38
 isupper..... 46
 isvector..... 38
 isxdigit..... 46

J

jet707..... 248

K

kbhit..... 114
 kendall..... 205
 keyboard..... 114
 kolmogorov_smirnov_cdf..... 219
 kolmogorov_smirnov_test..... 208
 kolmogorov_smirnov_test_2..... 209
 kron..... 181
 kruskal_wallis_test..... 209
 krylov..... 180
 kurtosis..... 202

L

laplace_cdf..... 219
 laplace_inv..... 219
 laplace_pdf..... 219
 laplace_rnd..... 220
 lasterr..... 106
 lastwarn..... 106
 lcm..... 162
 length..... 30
 lgamma..... 170
 lin2mu..... 295
 link..... 304
 linspace..... 157
 list..... 51
 load..... 116
 loadaudio..... 295
 loadimage..... 292
 localtime..... 300

log..... 162
 log10..... 162
 log2..... 162
 logistic_cdf..... 220
 logistic_inv..... 220
 logistic_pdf..... 220
 logistic_regression..... 213
 logistic_rnd..... 220
 logit..... 205
 loglog..... 139
 loglogerr..... 141
 logm..... 180
 lognormal_cdf..... 220
 lognormal_inv..... 220
 lognormal_pdf..... 220
 lognormal_rnd..... 220
 logspace..... 158
 lqe..... 276
 lqg..... 276
 lqr..... 277
 ls..... 312
 lsim..... 278
 lsode..... 187
 lsode_options..... 188
 lstat..... 305
 ltifir..... 268
 lu..... 176
 lyap..... 257

M

mahalanobis..... 202
 manova..... 209
 max..... 162
 mcnemar_test..... 210
 mean..... 201
 meansq..... 205
 median..... 201
 menu..... 113
 mesh..... 142
 meshdom..... 142
 meshgrid..... 142
 min..... 163
 minfo..... 245
 mkdir..... 305
 mkfifo..... 305
 mkttime..... 300
 mod..... 163
 moddemo..... 278
 moment..... 205
 more..... 109
 mplot..... 143

mu2lin 295
 multiplot 143

N

nargchk 95
 nargin 93
 nargout 95
 newtroot 78
 nextpow2 163
 norm 174
 normal_cdf 221
 normal_inv 221
 normal_pdf 221
 normal_rnd 221
 nper 225
 npv 225
 nth 51
 ntsc2rgb 292
 null 175
 num2str 40
 nyquist 269

O

obsv 260
 ocean 293
 octave_config_info 315
 odessa 189
 odessa_options 190
 ols 199
 oneplot 143
 ones 155
 ord2 248
 orth 175

P

parallel 254
 pascal_cdf 221
 pascal_inv 221
 pascal_pdf 221
 pascal_rnd 222
 pause 304
 pclose 308
 periodogram 289
 permute 151
 perror 106
 pinv 175
 pipe 310
 place 278
 playaudio 296

plot 135
 plot_border 143
 pmt 225
 poisson_cdf 222
 poisson_inv 222
 poisson_pdf 222
 poisson_rnd 222
 polar 139
 poly 229
 polyderiv 229
 polyfit 230
 polyinteg 230
 polyout 231
 polyreduce 230
 polyval 230
 polyvalm 230
 popen 308
 popen2 308
 postpad 155
 pow2 163
 ppplot 204
 prepad 155
 printf 119
 probit 204
 prod 167
 prompt 278
 prop_test_2 210
 purge_tmp_files 137
 putenv 312
 puts 119
 pv 226
 pvl 226
 pwd 312
 pzmap 260

Q

qconj 297
 qcoordinate_plot 298
 qderiv 297
 qderivmat 297
 qinv 297
 qmult 298
 qqplot 204
 qr 176
 qtrans 298
 qtransv 298
 qtransvmat 298
 quad 185
 quad_options 185
 quaternion 297
 quit 16

qz 177
 qzhess 178
 qzval 258

R

rand 156
 randn 156
 randperm 157
 range 204
 rank 175
 ranks 204
 rate 226
 read_readline_init_file 22
 readdir 305
 readlink 304
 real 164
 record 296
 rectangle_lw 289
 rectangle_sw 289
 rehash 97
 rem 163
 rename 304
 replot 134
 repmat 156
 reshape 152
 residue 231
 reverse 51
 rgb_map 292
 rgb2ind 293
 rgb2ntsc 292
 rindex 42
 rldemo 278
 rlocus 279
 rmdir 305
 roots 231
 rot90 150
 rotdim 150
 round 164
 rows 30
 run_count 203
 run_history 22
 run_test 210

S

save 114
 saveaudio 295
 saveimage 293
 schur 178
 sec 165
 sech 166

semilogx 139
 semilogxerr 141
 semilogy 139
 semilogyerr 141
 set 134
 setgrent 314
 setpwent 313
 shg 134, 137
 shift 153
 show 134
 sign 164
 sign_test 210
 sin 165
 sinc 286
 sinetone 289
 sinewave 289
 sinh 166
 size 31
 skewness 202
 sleep 304
 sort 153
 sortcom 279
 source 100
 spearman 203
 spectral_adf 289
 spectral_xdf 289
 spencer 289
 splice 51
 split 42
 sprintf 120
 sqrt 164
 sqrtm 180
 ss 236
 ss2tf 279
 ss2zp 280
 sscanf 125
 stairs 139
 starp 280
 stat 305
 statistics 203
 std 201
 stdnormal_cdf 222
 stdnormal_inv 222
 stdnormal_pdf 222
 stdnormal_rnd 222
 step 267
 str2func 103
 str2mat 41
 str2num 44
 strcat 40
 strcmp 42
 strerror 106

strftime	301	t_test_regression.....	211
strjust.....	44	table.....	203
strptime	302	tan.....	165
strrep.....	42	tanh.....	166
studentize.....	203	tf2ss.....	280
subplot.....	144	tf2sys.....	239
substr.....	42	tf2zp.....	280
subwindow	144	tfout.....	246
sum.....	167	tic.....	303
sumsq.....	167	tilde_expand.....	307
svd.....	179	time.....	299
syl.....	181	title.....	142
syvester_matrix.....	159	tmpfile.....	130, 131
symlink.....	304	tmpnam.....	131
synthesis	290	toascii.....	44
sys2fir.....	236	toc.....	303
sys2ss.....	238	toeplitz.....	159
sys2tf.....	240	tolower.....	44
sys2zp.....	241	top_title	144
sysadd.....	248	toupper.....	45
sysappend	249	trace.....	175
syschnames	241	triangle_lw	290
syschtsam	241	triangle_sw	290
sysconnect	249	tril.....	154
syscont.....	250	triu.....	154
sysdimensions	241	type.....	59
sysdisc.....	250	typeinfo.....	29
sysdup.....	251	tzero.....	270
sysgetsignals	242	tzero2.....	270
sysgettsam.....	245		
sysgettype	243		
sysgroup	251		
sysmin.....	254		
sysmult.....	252		
sysout.....	246		
sysprune	252		
sysreorder	252		
sysrepdemo	234		
sysyscale	253		
syssetsignals	244		
syssub.....	253		
system.....	307		
sysupdate	245		
T		U	
t_cdf.....	223	u_test.....	211
t_inv.....	223	ugain.....	253
t_pdf.....	223	umask.....	305
t_rnd.....	223	undo_string_escapes.....	45
t_test.....	211	uniform_cdf	223
t_test_2	211	uniform_inv	223
		uniform_pdf	223
		uniform_rnd	223
		union.....	227
		unlink.....	305
		unwrap.....	286
		usage.....	106
		usleep.....	304

V

values	202
vander	159
var	203
var_test	212
vec	154
vech	154
vertcat	151
vol	226

W

waitpid	310
warning	105
weibull_cdf	224
weibull_inv	224
weibull_pdf	224
weibull_rnd	224
welch_test	212
wgt10	254
which	59
who	57
whos	57, 58
wiener_rnd	224
wilcoxon_test	212

X

xlabel	143
xor	147

Y

ylabel	143
yulewalker	290

Z

z_test	213
z_test_2	213
zeros	156
zgfmul	258
zgfslv	258
zginit	258
zgreduce	258
zgrownorm	258
zgscal	258
zgsgiv	258
zgshsr	258
zlabel	143
zp2ss	281
zp2sys	240
zp2tf	281
zpout	246

Operator Index

!		;	
!.....	71	33
!=.....	70		
&		=	
&.....	71	=.....	72
&&.....	72	==.....	70
,		[
,.....	30, 39, 69	[.....	33
(]	
(.....	65].....	33
)		 	
).....	65	71
*		72
*.....	69	~	
**.....	69	~.....	71
,		~=.....	70
,.....	33	"	
-		".....	30, 39
-.....	69	+	
--.....	75	+.....	68, 69
•		++.....	75
•.....	69	>	
*.....	69	>.....	70
**.....	69	>=.....	70
./.....	69	^	
+.....	68	^.....	69
^.....	69	\	
\.....	69	\.....	69
/			
/.....	69		

<		C	
<.....	70		
<=.....	70		
<>.....	70	colon	37